

CITY OF PINOLE

**Notice to Contractors, Instructions to Bidders,
Special Provisions, Proposal, and Contract for:**

SAN PABLO AVENUE REHABILITATION PROJECT

BID OPENING DATE: OCTOBER 25, 2021



Approved: September 15, 2021

Mayor, Norma Martinez-Rubin
Mayor Pro Tem, Vincent Salimi
Councilmember, Anthony Tave
Councilmember, Maureen Toms
Councilmember, Devin Murphy

By: Misha Kaur
Misha Kaur
Senior Project Manager

TABLE OF CONTENTS

NOTICE INVITING SEALED BIDS	NIB-1
INSTRUCTIONS TO BIDDERS	I-1
FORM OF PROPOSAL:	I-1
DELIVERY OF PROPOSALS:	I-1
MODIFICATIONS AND ALTERNATIVE PROPOSALS:	I-1
WITHDRAWAL OF PROPOSAL:	I-1
BIDDER'S SECURITY:	I-1
APPROXIMATE ESTIMATE:	I-1
ADDENDA:	I-2
QUESTIONS:	I-1
DISCREPANCIES IN PROPOSALS:	I-2
COMPETENCY OF BIDDERS:	I-2
BIDDER'S EXAMINATION OF SITE AND CONTRACT DOCUMENTS:	I-2
DISQUALIFICATION OF BIDDERS:	I-3
RETURN OF BID SECURITY:	I-3
AWARD OF CONTRACT:	I-3
ALTERNATES:	I-3
LISTING SUBCONTRACTORS:	I-3
EXECUTION OF AGREEMENT:	I-3
INSURANCE AND BONDS:	I-4
TELEPHONES:	I-4
INTERPRETATION OF PLANS AND DOCUMENTS:	I-4
SALES AND/OR USE TAXES:	I-4
BID PROTESTS:	I-4

EXHIBIT 15-G CONSTRUCTION CONTRACT DBE	I-6
EXHIBIT 15-H PROPOSER/CONTRACTOR GOOD FAITH EFFORT	I-9
GENERAL PROVISIONS (SECTION I)	GP-12
A. PROJECT PROVISIONS	GP-12
B. GENERAL PROJECT INFORMATION	GP-12
1. REQUIREMENTS	GP-12
2. DEFINITION OF TERMS	GP-12
3. CONFERENCE	GP-13
C. AWARD OF BID AND EXECUTION OF CONTRACT	GP-13
1. DECISION AS TO WHICH CONTRACTOR IS THE LOWEST RESPONSIBLE BIDDER	GP-13
2. NON-COLLUSION AFFIDAVIT	GP-13
3. EXECUTION OF THE CONTRACT	GP-13
4. CONTRACT BONDS	GP-14
5. INSURANCE	GP-14
6. COMPLIANCE WITH PROVISIONS OF THE PUBLIC CONTRACT	GP-14
7. REJECTION OF BIDS	GP-14
D. PROJECT PLANS	GP-14
E. NOTICE TO PROCEED	GP-14
F. LEGAL RELATIONS AND RESPONSIBILITY TO THE CITY	GP-15
1. LAWS TO BE OBSERVED	GP-15
2. SOCIAL SECURITY REQUIREMENTS	GP-15
3. PREVAILING WAGES	GP-16
4. PENALTIES	GP-16
5. WORKING HOURS	GP-16
6. APPRENTICES	GP-16
7. REGISTRATION AND LICENSING OF CONTRACTORS	GP-17

8. PERMITS AND LICENSES	GP-17
9. PATENTS	GP-17
10. INDEMNITY	GP-17
11. NOTICE	GP-17
12. CONTRACTOR'S RESPONSIBILITY FOR WORK	GP-17
13. MAINTENANCE AND GUARANTEE	GP-18
14. COOPERATION	GP-18
G. PROSECUTION AND PROGRESS OF THE WORK	GP-18
1. WORK SCHEDULE	GP-18
2. SUBLETTING AND ASSIGNMENT	GP-18
3. CHARACTER OF WORKERS	GP-19
4. AGENTS OR FOREMAN	GP-19
5. TEMPORARY STOPPAGE OF CONSTRUCTION ACTIVITIES	GP-19
6. TIME OF COMPLETION AND LIQUIDATED DAMAGES	GP-19
7. SUSPENSION OF CONTRACT	GP-20
H. MEASUREMENT AND PAYMENT	GP-20
1. MEASUREMENT AND PAYMENT	GP-20
2. FINAL INVOICE AND PAYMENT	GP-20
3. EXTRA WORK	GP-21
4. UNPAID CLAIMS	GP-21
5. ACCEPTANCE	GP-22
I. CONTROL OF WORK	GP-22
1. AUTHORITY OF THE CITY ENGINEER	GP-22
2. CONFORMITY WITH PLANS AND ALLOWABLE VARIATION	GP-22
3. PROGRESS OF THE WORK	GP-22
4. SAMPLES	GP-22

5. TRADE NAMES AND ALTERNATIVES	GP-23
6. PROTECTION OF WORK	GP-23
7. CONFLICT OF TERMS	GP-23
8. INTERPRETATION OF PLANS AND SPECIFICATIONS	GP-23
9. INCREASES AND DECREASES OF THE WORK TO BE DONE	GP-24
10. ALTERATIONS OF THE WORK TO BE DONE	GP-24
11. EXTRA WORK	GP-24
12. PUBLIC UTILITIES	GP-24
13. PROCEDURE IN CASE OF DAMAGE TO PUBLIC PROPERTY	GP-25
14. REMOVAL OF INTERFERING OBSTRUCTIONS	GP-25
15. QUALITY OF MATERIAL	GP-25
16. REMOVAL OF DEFECTIVE OR UNAUTHORIZED WORK	GP-26
17. SUPERVISION	GP-26
18. SOIL COMPACTION TESTING	GP-26
19. PRESERVATION OF PROPERTY	GP-27
20. DUST CONTROL	GP-27
21. SELECTED MATERIALS	GP-27
22. SURPLUS MATERIALS	GP-27
23. CLEAN UP	GP-27
24. EQUIPMENT REQUIREMENTS	GP-27
25. PROTECTION OF WORK AND PUBLIC	GP-28
26. SPRINKLER SYSTEMS	GP-28
27. CONTRACTOR'S SUPERINTENDENT AND PROJECT MANAGER	GP-28
28. WORK AFTER REGULAR HOURS	GP-28
29. CONTRACTOR'S DAILY REPORTS	GP-29
30. REQUEST FOR WORKING DAYS	GP-29

31. DEFECTIVE MATERIALS	GP-29
32. SOUND AND VIBRATION CONTROL REQUIREMENTS	GP-30
33. AIR POLLUTION CONTROL	GP-30
34. FINAL CLEANING UP	GP-30
35. CONTRACTOR'S REQUEST FOR FINAL INSPECTION	GP-30
36. RESOLUTION OF PUBLIC WORKS CLAIMS	GP-30
37. STATUTORY CLAIMS UNDER PUBLIC CONTRACT CODE SECTION 9204	GP-33
38. TRENCHES AND EXCAVATIONS	GP-36
39. STREET/PATHWAY CLOSURES	GP-36
40. PUBLIC CONVENIENCE AND SAFETY	GP-37
41. SANITARY CONVENIENCE	GP-38
42. CONSTRUCTION YARD	GP-38
43. EQUIPMENT REQUIREMENTS	GP-38
44. PRESERVATION OF PROPERTY	GP-39
45. NPDES COMPLIANCE/WATER POLLUTION CONTROL	GP-39
46. SAFETY, SANITARY AND MEDICAL REQUIREMENTS	GP-41
47. ELECTRICAL POWER	GP-41
48. PROTECTION OF UNDERGROUND FACILITIES	GP-42
49. AIR POLLUTION CONTROL	GP-42
50. PROJECT APPEARANCE	GP-42
51. WORK HOURS	GP-43
52. CONSTRUCTION STAKING	GP-43
PROJECT SPECIAL PROVISION (SECTION II)	PSP-1
1. GENERAL	PSP-1
2. CONSTRUCTION METHODS	PSP-3
3. MOBILIZATION	PSP-4

4. PROTECTION AND RESTORATION OF EXISTING IMPROVEMENTS	PSP-4
5. CLEARING AND GRUBBING	PSP-5
6. UNCLASSIFIED EXCAVATION	PSP-6
7. APPURTENANT WORK	PSP-7
8. COMPACTION TESTING	PSP-7
9. FURNISH AND APPLY WATER	PSP-7
10. CONSTRUCTION PHASING AND TRAFFIC CONTROL	PSP-8
11. CONSTRUCTION AREA SIGNS	PSP-14
12. ROADWAY SIGNS	PSP-15
13. UTILITY ADJUSTMENTS TO GRADE	PSP-17
14. CITY MONUMENT PRESERVATION	PSP-19
15. BASE FAILURE REPAIR	PSP-20
16. HOT MIX ASPHALT (TYPE A)	PSP-21
17. PAVEMENT STRIPING AND MARKINGS	PSP-25
18. CURB PAINT	PSP-28
19. CONCRETE CURB RAMP	PSP-29
20. WATER POLLUTION CONTROL	PSP-33
21. CONSTRUCTION STAKING	PSP-34
22. WOODEN RETAINING WALL	PSP-35
23. VEHICLE LOOP DETECTORS	PSP-36
CHAPTER 1 I. GENERAL	CH-1
CHAPTER 2 II. NONDISCRIMINATION	CH-2
CHAPTER 3 III. NONSEGREGATED FACILITIES	CH-6
CHAPTER 4 IV. DAVIS-BACON AND RELATED ACT PROVISIONS	CH-7
CHAPTER 5 V. CONTRACT WORK HOURS AND SAFETY STANDARDS ACT	CH-13
CHAPTER 6 VI. SUBLETTING OR ASSIGNING THE CONTRACT	CH-13

CHAPTER 7 VII. SAFETY: ACCIDENT PREVENTION	CH-15
CHAPTER 8 VIII. FALSE STATEMENTS CONCERNING HIGHWAY PROJECTS	CH-15
CHAPTER 9 IX. IMPLEMENTATION OF CLEAN AIR ACT AND FEDERAL WATER POLLUTION CONTROL ACT	CH-16
CHAPTER 10 X. CERTIFICATION REGARDING DEBARMENT, SUSPENSION, INELIGIBILITY AND VOLUNTARY EXCLUSION	CH-16
CHAPTER 11 XI. CERTIFICATION REGARDING USE OF CONTRACT FUNDS FOR LOBBYING	CH-20
CHAPTER 12 XII. USE OF UNITED STATES-FLAG VESSELS:	CH-21
CHECKLIST FOR BIDDERS	CH-22
PROPOSAL	P-1
BID SCHEDULE	P-3
INFORMATION REQUIRED OF BIDDER	P-5
STATEMENT ACKNOWLEDGING PENAL AND CIVIL PENALTIES CONCERNING THE CONTRACTORS' LICENSING LAWS	P-7
DESIGNATION OF SUBCONTRACTORS	P-9
CONTRACTOR'S INDUSTRIAL	P-11
SAFETY RECORD	P-11
BID BOND	P-12
NONCOLLUSION AFFIDAVIT	P-14
CITY OF PINOLE CHECKLIST FOR EXECUTION OF CONSTRUCTION CONTRACT	P-15
CONTRACT	C-1
INSTRUCTIONS FOR EXECUTION OF INSTRUMENTS	C-4
INSURANCE REQUIREMENTS FOR CITY OF PINOLE	C-5
PAYMENT BOND	C-7
PERFORMANCE BOND	C-9
WORKER'S COMPENSATION CERTIFICATE OF INSURANCE	C-11
AGREEMENT TO COMPLY WITH	C-13

CALIFORNIA LABOR LAW REQUIREMENTS	C-13
INDEMNIFICATION AND HOLD HARMLESS AGREEMENT	C-15
ADDITIONAL INSURED ENDORSEMENT COMPREHENSIVE GENERAL LIABILITY	C-17
ADDITIONAL INSURED ENDORSEMENT AUTOMOBILE LIABILITY	C-19
ADDITIONAL INSURED ENDORSEMENT EXCESS LIABILITY	C-22
APPENDICES	APP-1
APPENDIX I – GARBAGE PICK UP SCHEDULE	APP-2
APPENDIX II – PROJECT PLANS	APP-3

CITY OF PINOLE

PLANS & SPECIFICATIONS FOR:

San Pablo Avenue Pavement Rehabilitation

NOTICE INVITING SEALED BIDS

CITY OF PINOLE

BIDS MUST BE RECEIVED BY: 10:00 am (Pacific Standard Time) on October 25, 2021

BIDS TO BE OPENED AT: City of Pinole, City Hall
2131 Pear Street
Pinole, CA 94564

PLACE OF BID RECEIPT: Department of Public Works
Attn: Misha Kaur, Sr. Project Manager
City Hall, 2131 Pear Street
Pinole, California 94564

NOTICE IS HEREBY GIVEN that the City of Pinole, County of Contra Costa, California, will receive up to, but not later than the time set forth above, sealed contract bids for the award of a contract for the project described in this document. All bids shall be made on the form furnished by the City and shall be opened and publicly read aloud at the above-stated time at the place of bid identified above.

Sealed bids must be placed in a sealed package with the project name and identification number typed or clearly printed on the lower left corner of the package.

PROJECT IDENTIFICATION NAME: San Pablo Avenue Pavement Rehabilitation Project

DESCRIPTION OF WORK: The Work generally consists of the installation of curb ramps, retaining walls, pavement stripes and markings, base failure repairs, and asphalt pavement grinding and overlay along San Pablo Avenue between Pinole Shores Drive to the westerly City limits. Refer to the Plans for a detailed description of the location. More specifically, the Work consists of, but is not limited to, saw-cutting; removal of existing asphalt concrete and Portland Cement concrete pavements, curb, gutter, ramps, and sidewalk, as required; construction of new portland cement concrete curb, gutter, ramps, and installation of asphalt concrete pavement, adjusting storm drain and utility boxes to grade, installation of pavement striping and markings, traffic control, installation of traffic signal loop detectors, associated wiring, wooden retaining wall, and conforming to adjacent landscape areas. Work around and in the City right of way is required. The Work includes preparation and submittal of a Construction Phasing Plan, as well as Traffic Control Plans for each phase of work. The Contractor is responsible to obtain and comply with all necessary permits and approvals to perform the work. The Contractor shall also coordinate the local transit authority, business owners, and homeowners to make necessary accommodations for access to driveways and bus stops.

COMPLETION OF WORK: All work shall be completed within the contract period 95 working days following the written Notice to Proceed.

OBTAINING BID DOCUMENTS: Contract documents for the above referenced project may be downloaded free of charge from the City of Pinole webpage at <http://www.ci.pinoles.ca.us/bids> (select: SAN PABLO AVENUE PAVEMENT REHABILITATION PROJECT under the Open Bids sections). The bid documents will also be posted on www.publicpurchase.com.

Each bid response shall be accompanied by the bid securities attachments required as part of this Request for Bid. This may include, but not be limited to such items as: a list of proposed subcontractors, evidence of insurance, performance bond and a labor and materials bond as specified in the contract documents.

In accordance with California Public Contract Code Section 3400, bidders may propose equals of products listed in the technical specifications or project plans by manufacturer name, brand or model number, unless the technical specifications or plans specify that the product is necessary to match others in use. Complete information for products proposed as equals must be submitted to the Public Works Officer for review at least 10 days before the time specified for bid opening in accordance with the bidders instructions contained in the bid package.

Each bid in excess of \$175,000 must include an accurate bidder's questionnaire properly completed on behalf of the bidder and signed by a representative authorized to bind the bidder. The City will use the information contained in the questionnaire to determine whether, pursuant to applicable law, a bidder is deemed a responsible bidder for purposes of this project. The information contained in the bidder's questionnaire or the omission of relevant information may, in itself, be sufficient to support a determination that a bidder is non-responsive.

Pursuant to the Labor Code of the State of California (California Labor Code Section 1770 *et seq.*) the Director of Industrial Relations has determined the general prevailing rate of wages and employer payments for health and welfare, vacation, pension and similar purposes applicable to the work to be done. This rate and scale are on file with the CITY ENGINEER and copies will be made available to any interested party on request. The information is also available on the state's Department of Industrial Relations Division of Labor Statistics and Research Website www.dir.ca.gov/dlsr. The Contractor to whom the contract is awarded and the subcontractors under him must pay not less than these rates for this area to all workers employed in the execution of this contract.

All Contractors bidding on this project are required to register with the Department of Industrial Relations (DIR) and to pay the required annual fee. Under California Labor Code section 1771.1, as amended by SB 854, unless registered with the DIR, a Contractor may not bid or be listed as a Subcontractor for any bid proposal submitted for public works projects.

Each bidder must submit a bid to the City, addressed to the CITY ENGINEER on the standard forms available in the office of CITY ENGINEER. The bid must be accompanied by a cash deposit, a certified or cashier's check or a bidder's bond issued by a California admitted surety insurer, made payable to the Owner, in an amount not less than 10 percent of the total bid submitted. Bids shall remain valid and shall not be subject to withdrawal for ninety (90) calendar days after the bid opening date.

In accordance with California Public Contract Code Section 3300, the bidder must possess a valid **Class A – General Engineering contractor's license** <http://www.cslb.ca.gov>. No contract will be awarded to any bidder who at bid opening is not a properly licensed California contractor as required by the California Business and Professions Code.

The Contractor may, at Contractor's sole cost and expense, substitute securities equivalent to any monies withheld by the Owner as provided in California Public Contract Code Section 22300. No such substitution shall be accepted until all documents related to such substitution are reviewed and found acceptable by the Owner's attorney.

There is a \$1,500.00 per day assessment for liquidated damages for each calendar day that work remains incomplete beyond the time specified for the completion of the work. Refer to the bid specifications and contract documents for further details.

The City reserves the right to reject any or all bids or any parts thereof and waive any irregularities or informalities in any bid or in the bidding and to make awards in all or part in the best interest of the City in accordance with applicable law.

No bidder may withdraw his bid for a period of ninety (90) days after the date set for the opening bids.

BID RIGGING The U.S. Department of Transportation (DOT) provides a toll-free hotline to report bid rigging activities. Use the hotline to report bid rigging, bidder collusion, and other fraudulent activities. The hotline number is (800) 424-9071. The service is available 24 hours 7 days a week and is confidential and anonymous. The hotline is part of the DOT's effort to identify and investigate highway construction contract fraud and abuse and is operated under the direction of the DOT Inspector General.

CITY OF PINOLE

By: Misha Kaur 09/29/2021
Misha Kaur _____
Senior Project Manager Date

INSTRUCTIONS TO BIDDERS

FORM OF PROPOSAL:

The proposal shall be made on the bidding schedule ("proposal") herein. The proposal shall be enclosed in a sealed envelope bearing the name of the bidder and the name of the project as described under Notice Inviting Sealed Bids.

DELIVERY OF PROPOSALS:

The proposal shall be delivered by the time and to the place stipulated in the Notice Inviting Sealed Bids. It is the bidder's sole responsibility to see that his proposal is received in proper time. Any proposal received after the scheduled closing time for receipt of proposals will be returned to the bidder unopened unless the City has granted an extension. Bidders or their authorized agents are invited to be present.

MODIFICATIONS AND ALTERNATIVE PROPOSALS:

Unauthorized conditions, limitations or provisos attached to a proposal will render it non-responsive and may be cause for rejection. The complete proposal forms shall be without interlineations, alterations or erasures, unless each such correction is suitably authenticated by affixing in the margin immediately opposite the correction the surname or surnames of the person or persons signing the bid. No oral, telegraphic or telephonic proposals or modifications will be considered.

WITHDRAWAL OF PROPOSAL:

The proposal may be withdrawn upon request by the bidder without prejudice prior to, but not after, the time fixed for opening of bids, provided that the request is in writing, has been executed by the bidder or his duly authorized representative, and is filed with the CITY ENGINEER. No proposal may be withdrawn during the period of ninety (90) calendar days after the opening of proposals.

BIDDER'S SECURITY:

Each bid shall be accompanied by certified or cashier's check payable to the City, or a satisfactory bid bond in favor of the City executed by the bidder as principal and a California admitted surety as surety, in an amount not less than ten percent (10%) of the amount set forth in the bid. The check or bid bond shall be given as a guarantee that the bidder shall execute the contract if it is awarded to him in conformity with the contract documents and shall provide the evidence of insurance and furnish the necessary bonds as specified in the contract documents, within fifteen (15) calendar days after written notice of the award. In case of the bidder's refusal or failure to do so, the cash, check, or bond, as the case may be, shall be forfeited to the City. No bidder's bond will be accepted unless it conforms substantially to the form set forth as required.

APPROXIMATE ESTIMATE:

The quantities shown in the proposal form shall be considered as approximate only, being listed therein for the purpose of serving as a general indication of the amount of work or materials to be performed or furnished, and as a basis for the comparison of bids; and the City does not guarantee nor agree, either expressly or by implication, that the actual amount required will correspond therewith, but reserves the right to increase or decrease the amount of any item or portion of work or material to be performed or furnished, or to omit any such item or portion, in accordance with the Special Provisions or Standard Specifications, under which the work is to be constructed, without any way invalidating the contract, should such increase, decrease or omission be deemed necessary or expedient.

ADDENDA:

The CITY may, from time to time, issue addenda to the contract documents during the period of advertising for bids. Addenda will be posted on www.ci.pinole.ca.us/bids and on www.publicpurchase.com.

QUESTIONS:

Questions regarding the project should be directed to Misha Kaur, by written Requests for Information (RFI) to mkaur@ci.pinole.ca.us, no later than ten (business) days before bid opening. Responses to questions will be posted on www.ci.pinole.ca.us/bids under the project.

DISCREPANCIES IN PROPOSALS:

The bidder shall set forth each item of work, in clearly legible figures, a unit or line item bid for the item in the respective spaces provided for this purpose.

In case of discrepancy between the unit price and the total set forth for the item, the unit price shall prevail, provided, however, if the amount set forth as a unit price is ambiguous, unintelligible or uncertain for any cause, or is omitted, or in the case where the unit price is the same amount as the entry in the "Total" column, then the amount set forth in the "Total" column for the item shall prevail in accordance with the following:

- (1) As to lump sum items, the amount set forth in the "Total" column shall be the unit price.
- (2) As to unit price items, the amount set forth in the "Total" column shall be divided by the estimated quantity for the item and the price thus obtained shall be the unit price.

In case of discrepancy between words and figures, the words shall prevail.

COMPETENCY OF BIDDERS:

In selecting the lowest responsible bidder, consideration will be given not only to the financial standing, but also to the general competency of the bidder for the performance of the work covered by the proposal. To this end, a statement of the bidder's experience on the form entitled "Information Required of Bidder" bound herein shall support each proposal.

No agreement for the work will be executed with a contractor who is not licensed in accordance with the laws of the State of California under applicable provisions of the Business and Professions Code. The licensing requirements for contractors shall apply also to subcontractors. All bidders submitting a bid in excess of \$175,000 must complete the City's qualification form, and must pass all qualification criteria.

Contractors must sign the "Statement Acknowledging Penal & Civil Penalties Concerning the Contractor's Licensing Laws."

Each bid must include an accurate bidder's questionnaire properly completed on behalf of the bidder and signed by a representative authorized to bind the bidder. The City will use the information contained in the questionnaire to determine whether, pursuant to applicable law, a bidder is deemed a responsible bidder for purposes of this project. The information contained in the bidder's questionnaire or the omission of relevant information may, in itself, be sufficient to support a determination that a bidder is non-responsive.

BIDDER'S EXAMINATION OF SITE AND CONTRACT DOCUMENTS:

Bidders must satisfy themselves by personal examination of the location of the proposed work and by such other means as they may prefer as to the proposal, plans, specifications, contract form and actual conditions and requirements of the work, and shall not at any time after submission of the bid, dispute, complain, or assert that there was any misunderstanding in regard to the conditions to be encountered, the character, quality, and quantities of work to be performed and materials to be furnished, and the requirements of the proposal, plans, specifications, and the contract form. The submission of a proposal shall be considered conclusive evidence that the bidder has made such examination.

DISQUALIFICATION OF BIDDERS:

No person, firm, or corporation shall be allowed to make, file or be interested in more than one bid for the same work, unless alternate bids are specifically called for. A person, firm or corporation that has submitted a subproposal to a bidder, or that has quoted prices of materials to a bidder is not hereby disqualified from submitting a subproposal or quoting prices to other bidders or making a prime proposal. If there is a reason to believe that collusion exists among the bidders, all bids will be rejected.

RETURN OF BID SECURITY:

The successful bidder's proposal guarantee shall be held until the contract is executed. Bid security shall be returned to unsuccessful bidders within twenty (20) calendar days after the successful bidder has signed the contract.

AWARD OF CONTRACT:

The City reserves the right to reject any or all bids or any parts thereof or to waive any irregularities or informalities in any bid or in the bidding. The award of the contract, if made by the City, will be to the lowest responsible and qualified bidder. The award, if made, will be within ninety (90) calendar days after the opening of the proposals; provided that the award may be made after said period if the successful bidder has not given the City written notice of the withdrawal of his bid.

ALTERNATES:

If alternate bids are called for, the contract shall be awarded to the lowest responsible bidder on the base bid.

LISTING SUBCONTRACTORS:

Each bidder shall submit a list of the proposed subcontractors on this project, as required by the Subletting and Subcontracting Fair Practices Act (Public Contract Code Sections 4100, et seq.) and Title 49, Section 26.11 of the Code of Federal Regulations. Forms for this purpose are furnished with the contract documents.

EXECUTION OF AGREEMENT:

The bidder to whom award is made shall execute a written contract with the City in the form included in these contract documents and shall secure and provide to City all insurance and bonds as herein specified within fifteen (15) calendar days from the date of mailing of written notice of the award. Failure or refusal to enter into the agreement or to conform to any of the stipulated requirements shall be just cause for the annulment of the award and forfeiture of the bidder's security. In the event the bidder to whom an award is made fails or refuses to execute the Agreement within said time, the City may declare the bidder's security forfeited, and it may award the work to the next lowest bidder, or may call for new bids.

If the successful bidder refuses or fails to execute the contract, the City may award the contract to the second lowest responsible bidder. If the second lowest responsible bidder

refuses to execute the contract, the City may award the contract to the third lowest responsible bidder to execute the contract; such bidder's securities shall be likewise forfeited to the City.

INSURANCE AND BONDS:

The Contractor shall not begin work under the Agreement until it has given the City evidence of comprehensive public liability insurance and Workers' Compensation Insurance coverage. The successful Contractor shall also furnish two (2) bonds required by the State Contract Act. Each of the said bonds shall be executed in a sum equal to the contract price. One of the said bonds shall guarantee the faithful performance of the said contract by the Contractor, and the other said bond shall secure the payment of claims for labor and material.

TELEPHONES:

Bidders are hereby notified that City will not provide telephones for their use at the time of receipt of bids.

INTERPRETATION OF PLANS AND DOCUMENTS:

If any person contemplating submitting a bid for the proposed contract is in doubt as to the true meaning of any part of the drawings, specifications or other contract documents, or finds discrepancies in or omissions from the drawings and specifications, he or she may submit to the CITY ENGINEER a written request for an interpretation or correction. The person submitting the request will be responsible for its prompt delivery. Any interpretation or correction of the contract document will be made only by an Addendum duly issued, and a copy of such Addendum will be posted on www.ci.pinole.ca.us/bids and on www.publicpurchase.com. No oral interpretation of any provision in the contract documents shall be binding.

SALES AND/OR USE TAXES:

Except as may be otherwise specifically provided herein, all sales and/or use taxes assessed by federal, state or local authorities on materials used or furnished by the Contractor in performing the work hereunder shall be paid by the Contractor.

BID PROTESTS:

The City will use reasonable effort to notify all bidders of its intent to award the subject project to all bidders who submit satisfactory Proposals no later than the first business day after the City has awarded the project, although any delay or failure to do so will not extend the Proposal protest deadline. Any Proposal protest must be submitted in writing to City at the Office of the CITY ENGINEER. at the address specified above, before 2:00 p.m. of the fifth (5th) business day following the City's award of the project. Protests must conform to the following:

- The initial protest document must contain a complete statement of the specific basis (or bases) for the protest and must be accompanied by a certified or cashier's check made out to the "City of Pinole" in the amount five hundred dollars (\$500) in order to reimburse the City for expenses in reviewing and handling the protests. This fee is refundable if protest is upheld by the City Council.
- The protest must include the name, address and telephone number of the person representing the protesting party.

- The bidder filing the protest must transmit a copy of the initial protest document and any attached documentation concurrently to all other parties with a direct financial interest that may be adversely affected by the outcome of the protest. Such parties shall include all other bidders with satisfactory Proposals.
- The procedure and time limits set forth in this paragraph are mandatory and are a bidder's sole and exclusive remedy in the event of proposal protest. A bidder's failure to comply with these procedures shall constitute a waiver of any right to further pursue its proposal protest including the filing a Government Code Claim or instituting separate legal proceedings. A bidder may not rely on a protest submitted by another bidder, but must timely pursue its own protest.

EXHIBIT 15-G CONSTRUCTION CONTRACT DBE COMMITMENT

1. Local Agency: City of Pinole 2. Contract DBE Goal: 10%
 3. Project Description: Cold mill between 2.5 - 5 inches of asphalt concrete pavement & replace with new HMA, upgrade non-compliant curbs ramps to meet ADA standards, install a retaining wall at back of sidewalk & new thermoplastic striping.
 4. Project Location: On San Pablo Avenue in Pinole from the western City limits to Pinole Shores Drive.
Pinole, CA
 5. Bidder's Name: _____ 6. Prime Certified DBE: 7. Bid Amount: _____
 8. Total Dollar Amount for **ALL** Subcontractors: _____ 9. Total Number of **ALL** Subcontractors: _____

10. Bid Item Number	11. Description of Work, Service, or Materials Supplied	12. DBE Certification Number	13. DBE Contact Information (Must be certified on the date bids are opened)	14. DBE Dollar Amount

Local Agency to Complete this Section upon Execution of Award		15. TOTAL CLAIMED DBE PARTICIPATION	\$
21. Local Agency Contract Number: _____ 22. Federal-Aid Project Number: _____ 23. Bid Opening Date: _____ 24. Contract Award Date: _____ 25. Award Amount: _____			%
Local Agency certifies that all DBE certifications are valid and information on this form is complete and accurate. _____ 26. Local Agency Representative's Signature 27. Date		IMPORTANT: Identify all DBE firms being claimed for credit, regardless of tier. Names of the First Tier DBE Subcontractors and their respective item(s) of work listed above must be consistent, where applicable with the names and items of the work in the "Subcontractor List" submitted with your bid. Written confirmation of each listed DBE is required. _____ 16. Preparer's Signature 17. Date	

28. Local Agency Representative's Name	29. Phone	18. Preparer's Name	19. Phone
30. Local Agency Representative's Title		20. Preparer's Title	

DISTRIBUTION: 1. Original – Local Agency
2. Copy – Caltrans District Local Assistance Engineer (DLAE). Failure to submit to DLAE within 30 days of contract execution may result in de-obligation of federal funds on contract.
3. Include additional copy with award package.

ADA Notice: For individuals with sensory disabilities, this document is available in alternate formats. For information call (916) 654-6410 or TDD (916) 654-3880 or write Records and Forms Management, 1120 N Street, MS-89, Sacramento, CA 95814.

INSTRUCTIONS – CONSTRUCTION CONTRACT DBE COMMITMENT

CONTRACTOR SECTION

- 1. Local Agency** - Enter the name of the local agency that is administering the contract.
- 2. Contract DBE Goal** - Enter the contract DBE goal percentage as it appears on the project advertisement.
- 3. Project Location** - Enter the project location(s) as it appears on the project advertisement.
- 4. Project Description** - Enter the project description as it appears on the project advertisement (Bridge Rehab, Seismic Rehab, Overlay, Widening, etc).
- 5. Bidder's Name** - Enter the contractor's firm name.
- 6. Prime Certified DBE** - Check box if prime contractor is a certified DBE.
- 7. Bid Amount** - Enter the total contract bid dollar amount for the prime contractor.
- 8. Total Dollar Amount for ALL Subcontractors** – Enter the total dollar amount for all subcontracted contractors. SUM = (DBEs + all Non-DBEs). Do not include the prime contractor information in this count.
- 9. Total number of ALL subcontractors** – Enter the total number of all subcontracted contractors. SUM = (DBEs + all Non-DBEs). Do not include the prime contractor information in this count.
- 10. Bid Item Number** - Enter bid item number for work, services, or materials supplied to be provided.
- 11. Description of Work, Services, or Materials Supplied** - Enter description of work, services, or materials to be provided. Indicate all work to be performed by DBEs including work performed by the prime contractor's own forces, if the prime is a DBE. If 100% of the item is not to be performed or furnished by the DBE, describe the exact portion to be performed or furnished by the DBE. See LAPM Chapter 9 to determine how to count the participation of DBE firms.
- 12. DBE Certification Number** - Enter the DBE's Certification Identification Number. All DBEs must be certified on the date bids are opened.
- 13. DBE Contact Information** - Enter the name, address, and phone number of all DBE subcontracted contractors. Also, enter the prime contractor's name and phone number, if the prime is a DBE.
- 14. DBE Dollar Amount** - Enter the subcontracted dollar amount of the work to be performed or service to be provided. Include the prime contractor if the prime is a DBE. See LAPM Chapter 9 for how to count full/partial participation.
- 15. Total Claimed DBE Participation** - \$: Enter the total dollar amounts entered in the "DBE Dollar Amount" column. %: Enter the total DBE participation claimed ("Total Claimed DBE Participation Dollars" divided by item "Bid Amount"). If the total % claimed is less than item "Contract DBE Goal," an adequately documented Good Faith Effort (GFE) is required (see Exhibit 15-H DBE Information - Good Faith Efforts of the LAPM).

- 16. Preparer's Signature** - The person completing the DBE commitment form on behalf of the contractor's firm must sign their name.
- 17. Date** - Enter the date the DBE commitment form is signed by the contractor's preparer.
- 18. Preparer's Name** - Enter the name of the person preparing and signing the contractor's DBE commitment form.
- 19. Phone** - Enter the area code and phone number of the person signing the contractor's DBE commitment form.
- 20. Preparer's Title** - Enter the position/title of the person signing the contractor's DBE commitment form.

LOCAL AGENCY SECTION

- 21. Local Agency Contract Number** - Enter the Local Agency contract number or identifier.
- 22. Federal-Aid Project Number** - Enter the Federal-Aid Project Number(s).
- 23. Bid Opening Date** - Enter the date contract bids were opened.
- 24. Contract Award Date** - Enter the date the contract was executed.
- 25. Award Amount** - Enter the contract award amount as stated in the executed contract.
- 26. Local Agency Representative's Signature** - The person completing this section of the form for the Local Agency must sign their name to certify that the information in this and the Contractor Section of this form is complete and accurate.
- 27. Date** - Enter the date the DBE commitment form is signed by the Local Agency Representative.
- 28. Local Agency Representative's Name** - Enter the name of the Local Agency Representative certifying the contractor's DBE commitment form.
- 29. Phone** - Enter the area code and phone number of the person signing the contractor's DBE commitment form.
- 30. Local Agency Representative Title** - Enter the position/title of the Local Agency Representative certifying the contractor's DBE commitment form.

EXHIBIT 15-H PROPOSER/CONTRACTOR GOOD FAITH EFFORTS

Federal-aid Project No(s). _____ Bid Opening Date: 10/25/2021 _____ CON

The City of Pinole established a Disadvantaged Business Enterprise (DBE) goal of 10% for this contract. The information provided herein shows the required good faith efforts to meet or exceed the DBE contract goal.

Proposers or bidders submit the following information to document their good faith efforts within five (5) calendar days from cost proposal due date or bid opening. Proposers and bidders are recommended to submit the following information even if the Exhibit 15-G: Construction Contract DBE Commitment indicate that the proposer or bidder has met the DBE goal. This form protects the proposer’s or bidder’s eligibility for award of the contract if the administering agency determines that the bidder failed to meet the goal for various reasons, e.g., a DBE firm was not certified at bid opening, or the bidder made a mathematical error.

The following items are listed in the Section entitled “Submission of DBE Commitment” of the Special Provisions, **please attach additional sheets as needed**:

- A. The names and dates of each publication in which a request for DBE participation for this project was placed by the bidder (please attach copies of advertisements or proofs of publication):

Publications	Dates of Advertisement

- B. The names and dates of written notices sent to certified DBEs soliciting bids for this project and the dates and methods used for following up initial solicitations to determine with certainty whether the DBEs were interested (please attach copies of solicitations, telephone records, fax confirmations, etc.):

Names of DBEs Solicited	Date of Initial Solicitation	Follow Up Methods and Dates

C. The items of work made available to DBE firms including those unbundled contract work items into economically feasible units to facilitate DBE participation. It is the bidder's responsibility to demonstrate that sufficient work to facilitate DBE participation in order to meet or exceed the DBE contract goal.

Items of Work	Proposer or Bidder Normally Performs Item (Y/N)	Breakdown of Items	Amount (\$)	Percentage Of Contract
				0.00%
				0.00%
				0.00%
				0.00%

D. The names, addresses and phone numbers of rejected DBE firms, the reasons for the bidder's rejection of the DBEs, the firms selected for that work (please attach copies of quotes from the firms involved), and the price difference for each DBE if the selected firm is not a DBE:

Names, addresses and phone numbers of rejected DBEs and the reasons for the bidder's rejection of the DBEs:

Names, addresses and phone numbers of firms selected for the work above:

E. Efforts (e.g. in advertisements and solicitations) made to assist interested DBEs in obtaining information related to the plans, specifications and requirements for the work which was provided to DBEs:

F. Efforts (e.g. in advertisements and solicitations) made to assist interested DBEs in obtaining bonding, lines of credit or insurance, necessary equipment, supplies, materials, or related assistance or services, excluding supplies and equipment the DBE subcontractor purchases or leases from the prime contractor or its affiliate:

G. The names of agencies, organizations or groups contacted to provide assistance in contacting, recruiting and using DBE firms (please attach copies of requests to agencies and any responses received, i.e., lists, Internet page download, etc.):

Name of Agency/Organization	Method/Date of Contact	Results

H. Any additional data to support a demonstration of good faith efforts:

GENERAL PROVISIONS (SECTION I)

A. PROJECT PROVISIONS

The project provisions applicable to this contract shall be those set forth in the State of California Department of Transportation (Caltrans) Standard Specifications, for Construction of Local Streets and Roads, 2015 Edition and the Caltrans Standard Plans, 2015 Edition. (hereinafter referred to as "Standard Specifications"),. The Standard Specifications and Plans are referred to and by this reference are made a part hereof as though set forth at length. The Contractor is required to comply with the Standard Specifications and Plans in addition to the conditions set forth in these General Provisions and Special Provisions.

B. GENERAL PROJECT INFORMATION

1. REQUIREMENTS

All work embraced herein shall be accomplished in accordance with the applicable portions of Standard Specifications and Plans, except as modified by these Special Provisions and the Project Plans.

In addition to the above, the Contractor shall comply with the requirements of the following:

- (a) Notice Inviting Sealed Bids
- (b) Instructions to Bidders
- (c) Proposal
- (d) Bid Bond
- (e) Information Required of Bidders
- (f) Contract Agreement
- (g) Faithful Performance Bond
- (h) Labor and Material Bond
- (i) Statement Acknowledging Penal and Civil Penalties Concerning the Contractor's Licensing Laws.
- (j) Insurance

2. DEFINITION OF TERMS

Wherever in the "Standard Specifications" terms are used, they shall be understood to mean and refer to the following:

Agency & Owner – City of Pinole

Board – City Council, City of Pinole

Engineer – The CITY ENGINEER, acting either directly or through the properly authorized agents, such agents acting within the scope of the particular duties entrusted to them.

Notice to Contractors - Notice Inviting Sealed Bids

3. CONFERENCE

The Contractor shall attend a preconstruction meeting with the CITY ENGINEER, which shall be held a minimum of five (5) working days prior to commencement of any work. The Contractor shall submit his 24-hour emergency telephone numbers to the CITY ENGINEER for approval a minimum of two (2) working days prior to the preconstruction conference.

C. AWARD OF BID AND EXECUTION OF CONTRACT

1. DECISION AS TO WHICH CONTRACTOR IS THE LOWEST RESPONSIBLE BIDDER

All bidders must submit with their proposals satisfactory evidence that they are capable of performing the work in accordance with plans and specifications. The CITY ENGINEER may require any bidder bidding on any public improvement to submit experience records covering a three-year period. The City Council may reject the bid of any bidder who has been delinquent or unfaithful in the performance of any previous contract work. The decision of the City Council as to which bidder is considered the "lowest responsible bidder" will be based not only on the actual amount of the bid, but also on the relative competence and experience of the bidders, with particular regard to the quality performance of any work done by them for the City or other entity in the past, and such decisions shall be final and binding upon all parties.

2. NON-COLLUSION AFFIDAVIT

The Contractor shall execute and return a "Non-collusion Affidavit" with its bid in the form attached herein.

3. EXECUTION OF THE CONTRACT

The contract, in the form set forth in the Contract Section shall be executed by the successful bidder in accordance with the Instruction for Execution of Documents and returned to the City for execution by the City, and shall be accompanied by bonds and the evidence of insurance required herein, all within fifteen (15) calendar days from the date written notice of the award is mailed to bidder. No bidder proposal shall be considered binding upon the City until such time as the City has executed it. Failure or refusal to enter a Contract as herein provided or to conform to any of the stipulated requirements in connection therewith shall be just cause for annulment of the award and forfeiture of the Bid Security. If the lowest responsible bidder refuses or fails to execute the Agreement, the City may award the contract to the second lowest responsible bidder. If the second lowest responsible bidder refuses or fails to execute the Agreement, the City may award the contract to the third lowest responsible bidder. On the failure or refusal of such second or third lowest bidder to execute the Contract, each such bidder's bid securities shall be likewise forfeited to City.

4. CONTRACT BONDS

The successful bidder shall furnish to the City at his own expense two-surety bonds. One bond shall be in the amount of 100 percent of the contract price in the form set forth in the Contract Section to guarantee faithful performance of the contract work. The other bond, in an amount not less than 100 percent of the contract price in the form set forth in the Contract Section shall be furnished to secure payment of those supplying labor and materials as required by California Civil Code section 3247. Each bond shall be executed in accordance with the instruction set forth in the Proposal Section and each bond shall be executed by a California admitted surety insurer acceptable to, and approved by the City Attorney.

5. INSURANCE

The Contractor shall at all times, during the term of this contract, carry, maintain and keep in full force and effect, a policy or policies of comprehensive public liability insurance with a California admitted insurance company with a Best's rating of no less than A:VII, within minimum limits of One Million Dollars (1,000,000.00) combined single limit coverage against any injury, death, loss or damage as a result of wrongful or negligent acts or omissions by the Contractor, together with an endorsement in substantially the form set forth in the Contract Section attached hereto. The Contractor shall also at all times during the term of this contract carry, maintain and keep in full force and effect a policy or policies of Workers' Compensation insurance as required by applicable laws and regulations and shall provide to the City evidence of such coverage in the form set forth herein.

6. COMPLIANCE WITH PROVISIONS OF THE PUBLIC CONTRACT

All Contracts shall conform with the provisions of Sections 4100 through 4114 (the "Subletting and Subcontracting Fair Practices Act"), inclusive, of the Public Contract Code, as amended, concerning subcontractors and subcontracts.

7. REJECTION OF BIDS

Bids may be rejected by the City Council where, upon evidence of a prior performance of the bidder, the City Council has made a finding that the bidder is not a responsible bidder because of unsatisfactory performance within the past three (3) years with the City or with any other public entity. The City reserves the right to reject any or all bids and to waive any irregularity or informality in any bid to the extent permitted by law.

D. PROJECT PLANS

The location of the work, its general nature, extent, form and detail of the various features are listed as a part of these Specifications and Plans.

E. NOTICE TO PROCEED

Upon award of this contract and signing the contract documents, the City shall issue the Contractor a Notice to Proceed. Contract period shall commence on the date in the Notice to Proceed. Working days are defined as Monday through Friday, with the exception that no work may take place on the following City holidays:

New Year's Day	January 1 st
Martin Luther King Jr's Birthday	3 rd Monday in January
Lincoln's Birthday	February 12 th
Washington's Birthday	3 rd Monday in February
Cezar Chavez's Birthday	March 31 st
Memorial Day	Last Monday in May
Juneteenth	June 19 th
Independence Day	July 4 th
Labor Day	1 st Monday in September
Columbus Day	2 nd Monday in October
Veteran's Day	November 11 th
Thanksgiving Day	4 th Thursday in November
Day after Thanksgiving Day	Day after Thanksgiving
Christmas	December 25 th

If January 1st, February 12th, March 31st, June 19th, July 4th, November 11th, or December 25th falls on a Sunday, the Monday following is a holiday. If November 11th falls on a Saturday, the preceding Friday is a holiday.

The City will not authorize any work to be done under these Specifications before the contract agreement has been fully executed; and any work that is done by the contractor in advance of such time shall be considered as being done at Contractor's own risk and responsibility, and as a consequence will be subject to rejection by not having been done in the presence of the CITY ENGINEER or Inspector as provided in Section 2-10 of the Standard Specifications.

In the event that the CITY ENGINEER shall be of the opinion that the work is being inadequately or improperly executed in any respect, he/she may demand that the Contractor improve or change the execution of the work in such manner as to assure proper and timely completion.

F. LEGAL RELATIONS AND RESPONSIBILITY TO THE CITY

1. LAWS TO BE OBSERVED

The Contractor shall keep himself or herself fully informed on all existing and pending State and federal laws and all municipal ordinances and regulations of the City, which in any manner affect those employed in the work, or the material used in the work, or which in any way affect the conduct of the work, and of all such orders and decrees of bodies or tribunals having jurisdiction or authority over the same. The Contractor shall observe all ordinances of the City in relations to the obstruction of streets or conduct of the work, keeping open passageways and protecting the same where they are exposed or dangerous to traffic.

2. SOCIAL SECURITY REQUIREMENTS

The Contractor shall furnish to the City satisfactory evidence that he and all subcontractors working for him are complying with all requirements of the Federal and State Social Security legislation. The Contractor, at any time on request, shall satisfy to

the City that the Social Security and Withholding taxes are being properly reported and paid.

3. PREVAILING WAGES

In accordance with California Labor Code Section 1771, not less than the general prevailing rate of per diem wages for work of a similar character in the locality in which the work is to be performed, and not less than the general prevailing rate of per diem wages for holiday and overtime work fixed as provided in the California Labor Code must be paid to all workers engaged in performing the work. In accordance with California Labor Code Section 1770 and following, the Director of Industrial Relations has determined the general prevailing wage per diem rates for the locality in which the Work is to be performed. In accordance with California Labor Code Section 1773.2, copies of the prevailing rate of per diem wages are on file at the City Public Works Department and will be made available on request. The information is also available on the website www.dir.ca.gov/dlsr Throughout the performance of the work the contractor must comply with all provisions of the Contract Documents and all applicable laws and regulations that apply to wages earned in performance of the work.

4. PENALTIES

The Contractor shall comply with the provisions of California Labor Code Sections 1774 and 1775 concerning the payment of prevailing rates of wages to workers and the penalties for failure to pay prevailing wages. The Contractor shall, as a penalty to the City, forfeit not more than fifty dollars (\$50) for each calendar day, or portion thereof, for each worker paid less than the prevailing rates as determined by the Director of Industrial Relations for the work or craft in which the worker is employed for any public work done under the contract by Contractor or by any subcontractor.

5. WORKING HOURS

The Contractor shall forfeit, as penalty to the City, the sum of twenty-five (\$25.00) dollars for each worker employed in the execution of the contract by Contractor or by any subcontractor under him for each calendar day during which such worker is required or permitted to work more than forty (40) hours in any one calendar week, in violation of the provisions of Article 3, Chapter 1, Part 7, Division 1 of the Labor Code (Section 1810 et. seq.). Working hours shall be limited to 8:30 AM – 4:30 PM.

6. APPRENTICES

Attention is directed to the provisions of Sections 1777.5 and 1777.6 of the Labor Code concerning the employment of apprentices by the Contractor or any subcontractor under Contractor. It shall be Contractor's responsibility to ensure that all persons shall comply with the requirements of said sections in the employment of apprentices.

Information relative to apprenticeship standards and administration of the apprenticeship program may be obtained from the Department of Industrial Relations, San Francisco, California, or from the Division of Apprenticeship Standards and its branch offices.

7. REGISTRATION AND LICENSING OF CONTRACTORS

Only a Contractor licensed in accordance with the provisions of Chapter 9, Division 3, of the Business and Professions Code shall be permitted to enter into a contract with the City for any public improvements.

8. PERMITS AND LICENSES

The Contractor shall procure all permits and licenses, including a City of Pinole business license, pay all charges and fees and give all notices necessary and incidental to the due and lawful prosecution of the work.

9. PATENTS

The Contractor shall assume all responsibility arising from the use of any patented, or allegedly patented materials, equipment, devices or processes used on or incorporated in the work, and shall defend, indemnify, and hold harmless the City, and each of its officers, agents, and employees from and against any and all liabilities, demands, claims, damages, losses, costs, and expenses, of whatsoever kind or nature, arising from such use.

10. INDEMNITY

The Contractor agrees to indemnify and hold harmless the City and others and to waive subrogation as set forth in the Indemnification and Hold Harmless Agreement and Waiver of Subrogation and Contribution executed concurrently herewith, a copy of which is attached hereto and incorporated herein by this reference.

11. NOTICE

The address given in the Contractor's proposal is the place to which all notices to the Contractor shall be mailed or delivered. The mailing to or delivering at the above named place of any notice shall be deemed sufficient service thereof upon the Contractor, and the date of that service shall be the date of such mailing or delivery. Such address may be changed at any time by written notice signed by the Contractor and delivered to the CITY ENGINEER.

12. CONTRACTOR'S RESPONSIBILITY FOR WORK

Until the final acceptance of the work by the City, by written action of the CITY ENGINEER, the Contractor shall have the charge and care thereof and shall bear the risk of injury or damage to any part of the work by the action of the elements or any other cause. The Contractor shall rebuild, repair, restore and make good all injuries or damages to any portion of the work occasioned by any cause before its completion and acceptance and shall bear the expense thereof, except for such injuries or damages arising from the sole negligence of willful misconduct of the City, its officers, agents or employees. In the case of suspension of work from any cause whatever, the Contractor shall be responsible for all materials and the protection of work already completed and shall properly store and protect them if necessary and shall provide suitable drainage and erect temporary structures where necessary.

13. MAINTENANCE AND GUARANTEE

(a) The Contractor hereby guarantees that the entire work constructed by Contractor under the contract will meet fully all requirements as to quality of workmanship and materials. The Contractor hereby agrees to make at Contractor's own expense any repairs or replacements made necessary by defects in materials or workmanship that become evident within one (1) year after the date of the final payment, and to restore to full compliance with the requirements of these specifications, including any test requirements set forth herein for any part of the project or work constructed hereunder, which during said one (1) year period is found to be deficient with respect to any provisions of the specifications. The Contractor shall make all repairs and replacements promptly upon receipt of written orders for the same from the CITY ENGINEER. The Contractor and Contractor's sureties shall be liable to the City for the cost thereof.

(b) The guarantees and agreements set forth in subsection (a) shall be secured by a surety bond which shall be delivered by the Contractor to the City before the Notice of Completion and acceptance of the work, by the CITY ENGINEER, as provided in Subsection 6-8 of the Standard Specifications. Said bond shall be in the form approved by the City Attorney and executed by a surety company or companies admitted in the State of California and satisfactory to the City, in the amount of 100 percent of the contract. Said bond shall remain in force for a period of one (1) year after the date of Notice of Completion and acceptance. Alternatively, the Contractor may provide for the Faithful Performance Bond furnished under the contract to remain in force and effect for said amount until the expiration of said one (1) year period.

14. COOPERATION

The Contractor is hereby notified that additional work within the work site may be scheduled during the course of this contract.

The Contractor shall cooperate with these and other projects in accordance with Sections 5-6 and 7-7 of the Standard Specifications.

Compensation for compliance shall be included in the various items of work, and no additional compensation shall be allowed therefore.

G. PROSECUTION AND PROGRESS OF THE WORK

1. WORK SCHEDULE

Prior to the Notice to Proceed, the Contractor shall submit a work schedule to the CITY ENGINEER for approval. Said schedule must show the dates of the expected start and completion of the various items of the contract work. The final schedule will be used as a controlling document throughout the construction period.

2. SUBLETTING AND ASSIGNMENT

The Contractor shall give Contractor's personal attention to the fulfillment of the contract and shall keep the work under Contractor's control. The Contractor shall not assign, transfer nor sublet any part of the work without the prior written consent of the City by the CITY ENGINEER and of the surety of the Contractor's bond, and such consent of Surety, together with a copy of the subcontract, shall be filed with the CITY

ENGINEER. No assignment, transfer or subletting, even though consented to, shall relieve the Contractor of Contractor's liabilities under the contract. Subcontractors shall not be recognized as such, and all persons engaged in the project will be considered as employees of the Contractor, their work being subject to the provisions of the contract and the specifications. Should any subcontractor fail to perform the work undertaken by him to the satisfaction of the CITY ENGINEER, said subcontractor shall be removed immediately from the project upon request by the CITY ENGINEER, shall not again be employed on the work, and the Contractor shall be held liable for the deficient work.

The Contractor shall submit to the City a list with the names, addresses and telephone numbers of all subcontractors who will work under Contractor.

3. CHARACTER OF WORKERS

The Contractor shall employ none but competent foremen, laborers and mechanics. Any overseer, superintendent, laborer or other person employed on the work by the Contractor who is intemperate, incompetent, troublesome or otherwise undesirable, or who fails or refuses to perform the work in the manner specified herein, shall be removed from jobsite immediately and such person shall not again be employed on the work.

4. AGENTS OR FOREMAN

In the absence of the Contractor from the site of the project, even if such is only of a temporary duration, Contractor must provide and leave at the site a competent and reliable English-speaking agent or foreman in charge. All notices, communications, orders or instructions given, sent to, or served upon, such agent or foreman by the CITY ENGINEER shall be considered as having been served upon the Contractor.

5. TEMPORARY STOPPAGE OF CONSTRUCTION ACTIVITIES

The CITY ENGINEER shall have the authority to suspend the contract work, wholly or in part, for such a period of time as the Director may deem necessary, due to unsuitable weather, or to such other conditions as the Director considers unfavorable for the proper prosecution of the work, or for such time as the Director may deem necessary due to failure on the part of the Contractor or Contractor's workers to carry out orders or to perform any of the requirements of the contract. The Contractor shall immediately comply with such an order from the CITY ENGINEER and shall not resume operations until so ordered in writing.

6. TIME OF COMPLETION AND LIQUIDATED DAMAGES

If all the contract work is not completed in all parts and requirements within the time specified in the contract documents, the City shall have the right to grant or deny an extension of time for completion, as may seem best to serve the interest of the City. The Contractor shall not be assessed with liquidated damages during any delay in the completion of the work caused by acts of God or of the Public Enemy, acts of the State, fire not due to acts of contractors, of subcontractors, floods, epidemics, quarantine, restrictions, strikes, freight embargo or unusually severe weather, delays of subcontractors due to such causes, or work suspensions directed by the CITY ENGINEER provided that the Contractor shall, within ten (10) days from the beginning of such delay, notify the City, in writing, of the cause of the delay. The City will

ascertain the facts and the extent of the delay, if any, and the finding thereon shall be final and conclusive. If the City deems it appropriate to assess the contractor liquidated damages, such damages shall be amount of \$1,000 per day.

7. SUSPENSION OF CONTRACT

If at any time, in the opinion of the CITY ENGINEER, the Contractor fails to supply an adequate working force, manufactured articles, or material of proper quality, or has failed in any other respect to prosecute the work with the diligence and force specified and intended by the terms of the contract, notice thereof in writing will be served upon Contractor, and should Contractor neglect or refuse to provide means for a satisfactory compliance with the contract within the time specified in said notice and as directed by the CITY ENGINEER, the CITY ENGINEER shall have the power to suspend the operation of the contract and discontinue all work or any part thereof, subject to review by the City Manager. Thereupon the Contractor shall discontinue such work, or such part thereof as the City may designate, and the City may thereupon, by contract or otherwise, as it may determine, complete the work or such part thereof, and charge the entire expense of so completing the work or any part thereof to the Contractor, and for such completion the City itself or its Contractors may take possession of and use, or cause to be used in the completion of the work, or any part thereof, any such materials, implements and tools of every description as may be found at the place of such work. All expenses charged under this paragraph shall be deducted and paid for by the City out of any moneys then due or to become due the Contractor under the contract, or any part thereof, and in such accounting the City shall not be held to obtain the lowest figure for the work for completing the contract, or any part thereof, or for ensuring its proper completion, but all sums paid therefore shall be charged to the Contractor. In case the expenses so charged are less than sum which would have been payable under the contract, if the same had been completed by the Contractor, the Contractor shall be entitled to receive the difference, and in case such expense shall exceed the amount payable under the contract, then the Contractor shall pay the amount of the excess to the City, upon completion of the work, without further demand being made therefore. In the determination of the question as to whether or not there has been any such noncompliance with the contract as to warrant the suspension or annulment thereof, the decision of the City Manager shall be binding on all parties to the contract.

H. MEASUREMENT AND PAYMENT

1. MEASUREMENT AND PAYMENT

Measure of the quantities of work and payments therefore shall be in accordance with Section 9 of the Standard Specifications. In accordance with Subsection 9-3.2 of the Standard Specifications, the monthly payment date shall be the last calendar day of each month. A measurement of work performed and a progress estimate of the value thereof based on the contract and of the monthly payment shall be prepared by the Contractor and submitted to the CITY ENGINEER before the tenth day of the following month for verification and payment consideration.

2. FINAL INVOICE AND PAYMENT

Whenever in the opinion of the CITY ENGINEER, the Contractor shall have completely performed the contract, the CITY ENGINEER shall notify the City Clerk that the contract has been completed in its entirety. The Contractor shall then submit to the

CITY ENGINEER for approval, a written statement of the final quantities of contract items for inclusion in the final invoice. Upon receipt of such statement, the CITY ENGINEER shall check the quantities included therein and shall authorize the Contractor to submit an invoice which in the CITY ENGINEER' opinion shall be just and fair, covering the amount and value of the total amount of work done by the Contractor. The CITY ENGINEER shall then file a Notice of Completion of the work herein agreed to be done by the Contractor.

On the expiration of thirty-five (35) days after the date of recording the Notice of Completion, the City shall pay to the Contractor the amount remaining after deducting from the amount of value stated in the invoice all prior payments to the Contractor and all amounts to be kept and retained under the provisions of the contract, and shall release the Faithful Performance Bond and Labor and Material Bond.

The Contractor may, at Contractor's sole cost and expense, substitute securities equivalent to any monies withheld by the Owner as provided in California Public Contract Code Section 22300. No such substitution shall be accepted until all documents related to such substitution are reviewed and found acceptable by the Owner's attorney.

3. EXTRA WORK

Extra work, when ordered in writing by the CITY ENGINEER, shall be paid for under a written change order in accordance with the terms therein provided. Payment for extra work will be based on one or a combination of the following:

1. Bid Items Prices
2. Force Account
3. Agreed Price
4. Specialist Billing

Payment by force account shall be determined in accordance with Section 9 of the Standard Specifications.

4. UNPAID CLAIMS

If upon or before the completion of the work herein agreed to be performed or at any time prior to the expiration of the period within which claims of lien may be filed for record as prescribed by the Code of Civil Procedure of the State of California, any person or persons claiming to have performed any labor or furnished any materials, supplies or services towards the performance of completion of this contract or if they have agreed to do so, shall file with the City a verified statement of such claim, or if any person shall bring against the City or any of its agents any action to enforce such claim, the City shall until the discharge thereof, withhold from the moneys that are under its control, as much as shall be sufficient to satisfy and discharge the amount in such notice or under such action claimed to be due, together with the cost thereof; provided, that if the City shall in its discretion permit the Contractor to file such additional bond as is authorized by the Code of Civil Procedure in a penal sum equal to one and one-quarter times the amount of said claim, said money shall not thereafter be withheld on account of such claim.

5. ACCEPTANCE

The parties agree that no certificate given shall be conclusive evidence of the faithful performance of the contract, either in whole or in part, and that no payment shall be construed to be in acceptance of any defective work or improper materials. Further, the certificate or final payment shall not terminate the Contractor's obligations under the warranty here in above. The Contractor agrees that payment of the amount due under the contract and the adjustments and payments due for any work done in accordance with any alterations of the same, shall release the City, the City Council and its officers and employees from any and all claims or liability on account of work performed under the contract or any alteration thereof.

I. CONTROL OF WORK

1. AUTHORITY OF THE CITY ENGINEER

The CITY ENGINEER shall decide any and all questions that may arise as to the quality and acceptability of materials furnished and work performed as to the manner of performance and rate of progress of the work, and any and all questions, which may arise as to the interpretation of the plans and specifications. The CITY ENGINEER shall likewise decide any and all questions as to the acceptable fulfillment of the contract on the part of the Contractor, and all questions as to claims and compensations. The decision of the CITY ENGINEER shall be final, and he shall have relative authority to enforce and make effective such decisions and an action as the Contractor fails to carry out promptly.

For the purposes of routine and normal supervision and coordination of work, the CITY ENGINEER is the City's authorized representative for all work within the scope of this agreement.

2. CONFORMITY WITH PLANS AND ALLOWABLE VARIATION

Finished surfaces shall in all cases conform with the lines, grades, cross-sections and dimensions shown on the plans. Minor deviations from approved plans, whenever required by the exigencies of construction, shall be determined in all cases by the CITY ENGINEER and authorized in writing.

3. PROGRESS OF THE WORK

The Contractor's working days shall begin on the date stated in the Notice To Proceed which will be issued following the scheduling conference. The Contractor shall diligently prosecute the work to completion before the expiration of the time limit appearing in the specifications.

4. SAMPLES

The Contractor shall furnish all products and materials required to complete the work. All materials and products must be of the specified quality and fully equal to samples, when samples are required. Whenever required, the Contractor shall submit to the CITY ENGINEER for test, and free of charge, samples of any one of the materials or products proposed to be used in the work. Said samples shall be delivered by the Contractor to the place within the City designated by the CITY ENGINEER. Rejected

materials must be immediately removed from the work by the Contractor and shall not again be brought back to the site.

5. TRADE NAMES AND ALTERNATIVES

For convenience in designation on the plans or in the specifications, certain equipment or articles or materials to be incorporated in the work may be designated under a trade name of manufacturer and the catalog information. The use of an alternative equipment or an article or equipment which is of equal quality and of the required characteristics for the purpose intended will be permitted, subject to the approval of the CITY ENGINEER, in accordance with the following required by Section 3400 of the Public Contract Code of the State of California:

The burden of proof as to the comparative quality and suitability of alternative equipment or articles or materials shall be upon the Contractor, and Contractor shall furnish, at Contractor's own expense, all information necessary or related thereto as required by the CITY ENGINEER. The CITY ENGINEER shall be the sole judge as to the comparative quality and suitability of alternative equipment or articles or materials and the Director's decision shall be final. All requests for substitution shall be submitted, together with all documentation necessary for the Director to determine equality, within 20 days following the award of the contract.

6. PROTECTION OF WORK

The Contractor shall continuously maintain adequate protection of all Contractor's work from damage, and the City will not be held responsible for the care or protection of any material, equipment or parts of work, except as expressly provided for in the specifications.

7. CONFLICT OF TERMS

The notice to bidders, proposal, plans, specifications and General Provisions are essential parts of the contract for a given project. These documents, together with the necessary bonds and bidder's guarantee, constitute the contract as defined herein, and a requirement included in one document shall be as binding as though included in all, as they are intended to be cooperative and to provide a description of the work to be done. Should there be any conflict or discrepancy between terms used, then the specifications shall govern over plans, and change orders and supplemental agreements shall govern over any other contract document.

8. INTERPRETATION OF PLANS AND SPECIFICATIONS

Should it appear that the work to be done, or any matter relative thereto, is not sufficiently detailed or explained on the plans or in the specifications, the Contractor shall request the CITY ENGINEER for such further explanation as may be necessary, and shall conform to such explanation or interpretation as part of the contract, so far as may be consistent with the intent of the original specifications. In the event or doubt of questions relative to the true meaning of the specifications, reference shall be made to the City Council, whose decision thereon shall be final.

9. INCREASES AND DECREASES OF THE WORK TO BE DONE

The City reserves the right to increase or decrease the quantity of any item or portion of the work described on the plans, the specifications or the proposal form or to omit portions of the work so described, as may be deemed necessary or expedient by the CITY ENGINEER and the Contractor shall agree not to claim or bring suit for damages, whether for loss of profits or otherwise, on account of any decrease or omission of any kind of work to be done.

10. ALTERATIONS OF THE WORK TO BE DONE

By mutual consent of the parties signatory to the contract, alterations, modifications or deviations from the type of work may be described on the plans, specifications or on the proposal form may be made without in any way making the contract void. The price to be paid by the City to the Contractor for such altered or modified work shall be agreed upon in writing, endorsed upon the original contract and signed by the proper parties to said contract.

Whenever, during the progress of the work, such changes or modifications are deemed necessary by the CITY ENGINEER and agreed upon, as aforesaid, said deviations shall be considered and treated as though originally contracted for, and shall be subject to all the terms, conditions and provisions of the original contract.

11. EXTRA WORK

New and unforeseen work will be classed as extra work only when said work is not covered and cannot be paid for under any of the various items or combination of items for which a bid price appears on the proposal form. The Contractor shall not do any extra work except upon written order from the CITY ENGINEER. Compensation for such extra work shall be previously agreed upon in writing between the Contractor and the CITY ENGINEER.

12. PUBLIC UTILITIES

All of the existing utility facilities except those to be relocated as shown on the plans will remain in place and the contractor will be required to work around said facilities. In case it should be necessary to remove the property of a public utility or franchise, such owner will, upon proper application by the Contractor, be notified by the CITY ENGINEER to move such property within a reasonable time, and the Contractor shall not interfere with said property until after the expiration of the time specified. The right is reserved to the owners of public utilities or franchises to enter upon the project site for the purpose of making repairs or changes in their property, which may be necessary as a result of the work. The Contractor shall also schedule and allow adequate time for those relocations or modifications necessary for the project by the respective utility owners. Employees and agents of the City shall likewise have the privilege of entering upon the street for the purpose of making any necessary repairs or replacements.

The Contractor shall employ and use only qualified persons, as hereinafter defined, to work in proximity to Pacific Gas & Electric. secondary, primary and transition facilities. The term "qualified person" shall mean one, who by reason of experience or instruction, is familiar with the operation to be performed and the hazards involved, as

more specifically defined in Section 2700 of Title 8 of the California Administrative Code. The Contractor shall take such steps as are necessary to assure compliance by any subcontractors.

The Contractor shall exercise due care to ensure that utility facilities are not damaged during his/her operations. The Contractor shall notify utility companies prior to the beginning of any work..

13. PROCEDURE IN CASE OF DAMAGE TO PUBLIC PROPERTY

Any portions of curb, gutter, sidewalk or any other City improvement damaged by the Contractor during the course of construction shall be replaced by the Contractor at Contractor's own cost, free of charges to the City. The cost of additional replacement of curb, gutter or sidewalk in excess of the estimated quantities shown in the proposal form and specifications, and found necessary during the process of construction, (but not due to damage resulting from carelessness on the part of the Contractor during Contractor's operation), shall be paid to the Contractor at the unit prices submitted in his bid. For the purposes of this contract, all curb termination stub-outs for traffic signal detectors are considered existing improvements. The Contractor at no cost to the Agency shall replace existing curb termination stub-outs damaged as a result of work required by the Plans and Specifications.

14. REMOVAL OF INTERFERING OBSTRUCTIONS

The Contractor shall remove and dispose of all debris, abandoned structures, tree roots and obstructions of any character met during the process of excavation, it is being understood that the cost of said removals are made a part of the unit price bid by the Contractor under the item for excavation or removal of existing work.

15. QUALITY OF MATERIAL

Materials shall be new, and of specified kind and quality, and fully equal to samples when samples are required. When the quality or kind of material or articles shown required under the contract is not particularly specified, the Contractor shall estimate that the City will require articles and materials representing the best of their class or kind or at least equal to the class or quality of similar articles or materials when specified. Materials shall be furnished in such quantities and kinds and at such times as to ensure uninterrupted progress for the work. They shall be stored properly and protected as required. The Contractor shall be entirely responsible for damage or loss by weather or any other cause.

16. REMOVAL OF DEFECTIVE OR UNAUTHORIZED WORK

It is the intent of the specifications that only first-class work, materials and workmanship will be acceptable. All work which is defective in its construction or deficient in any of the requirements of the specifications shall be remedied, or removed and replaced by the Contractor in an acceptable manner, and no compensation will be allowed for such correction. Any work done beyond the lines shown on the plans or established by the CITY ENGINEER, or any extra work done without written authority will be considered as unauthorized and will not be paid for. Upon failure on the part of the Contractor to comply forthwith with any order of the CITY ENGINEER made under the provisions of this paragraph, the CITY ENGINEER shall have authority to cause defective work to be remedied or removed and replaced, and unauthorized work to be removed, and to deduct the costs thereof from any moneys due or to become due the Contractor. If the work is found to be in compliance with these specifications, the CITY ENGINEER will furnish the Contractor with a certificate to that effect.

17. SUPERVISION

All manufactured products, materials and appliances used and installed and all details of the work shall at all times be subject to the supervision, test and approval of the CITY ENGINEER or his authorized representatives. The CITY ENGINEER or his authorized representatives shall have access to the work at all times during construction, and shall be furnished with every reasonable facility for securing full knowledge with regard to the progress, workmanship and character of the materials used or employed in the work.

Whenever the Contractor varies the period during which work is carried on each day, he shall give adequate notice to the CITY ENGINEER so that proper inspection may be provided. Any work done in the absence of the CITY ENGINEER or the CITY ENGINEER' agent will be subject to rejection. The inspection of the work shall not relieve the Contractor of any of his obligations to fulfill the contract as prescribed. Defective work shall be made good, and unsuitable materials may be rejected, notwithstanding the fact that such defective work and unsuitable materials have previously been accepted or estimated for payment.

The Contractor shall prosecute work on any State highway or with any railroad right-of-way only in the presence of an inspector representing the State Division of Highways or the railroad company, and any work done in the absence of such inspectors will be subject to rejection. The Contractor shall make the appropriate notification according to the instructions given on the State Encroachment Permit or railroad permit for all inspections, and shall post all bonds and certificates required by the permit. The permit shall be acquired by the Contractor at the Contractor's expense. A copy of the State Encroachment Permit and or railroad permit shall be provided to the CITY ENGINEER a minimum of 14 days prior to work being performed on any State Highway or railroad right of way. The Contractor shall pay for all testing and inspections required by a State Encroachment Permit or railroad permit.

18. SOIL COMPACTION TESTING

Any soil compaction testing and certification shall be certified by a Geotechnical Engineer and provided and paid for by the City.

19. PRESERVATION OF PROPERTY

Existing improvements in areas adjoining the property whereon demolition and removal is being performed shall be protected from injury or damage resulting from operations of the Contractor and the Contractor shall be responsible for such damage. In like manner any building, structure, tree, shrub, or other item designated for preservation on the property where demolition and removal is being performed shall be similarly protected and preserved.

20. DUST CONTROL

The Contractor shall prevent and alleviate dust with methods as may be warranted by the location and nature of the work and in accordance with Section 10-5 of the Standard Specifications. Failure to control such dust shall be cause for the CITY ENGINEER or his authorized representative to stop the work until said dust is controlled, and the Contractor shall have no recourse to collect from the City for any loss of time or expense sustained by him due to such suspension of work.

21. SELECTED MATERIALS

Existing materials excavated within the project limits that meet the Standard Specifications for trench backfill, topsoil, or other selected materials may be used to fulfill all or a portion of the requirements for such materials. No additional compensation will be allowed for excavation, stockpiling, overhaul, or placing selected materials encountered in the excavation.

22. SURPLUS MATERIALS

The Contractor shall furnish written consent from the owner of the property where it is intended to dispose of the surplus material. Surplus excavation shall become the property of the Contractor.

23. CLEAN UP

During all phases of construction, the Contractor shall maintain a clean work site; the Contractor shall be responsible for the removal and disposal of all concrete, asphalt, tree roots, and any other debris resulting from the work performed on a daily basis. Full compensation for clean up shall be considered as included in the prices for the various contract items.

24. EQUIPMENT REQUIREMENTS

The Contractor shall provide a lead car with a "Wide Load" warning sign to lead the movement of any equipment exceeding 7 feet in maximum horizontal dimension over any street to the location of the scheduled work site. Equipment in violation of the contract or applicable law will be subject to a fine of one hundred dollars for each violation as determined by the CITY ENGINEER or his authorized representative. Any other violations shall be subject to the Vehicle Code of the State of California. Full compensation for the cost of furnishing the lead vehicles and adhering to the requirements of this section shall be considered as included in the prices for the various contract items of work, and no additional compensation will be allowed therefore.

25. PROTECTION OF WORK AND PUBLIC

The Contractor shall take all necessary measures to protect work and prevent accidents during any and all phases of the work. The Contractor shall repair all damaged parts of the project as a result of vandalism (i.e., vehicle tracks, footprints, writing, etc.) and will respond to alleged damage to private property and/or vehicles within twenty four (24) hours of notification. If deemed necessary by the City, the Contractor shall repair the defective area in accordance with these Special Provisions.

26. SPRINKLER SYSTEMS

Any sprinkler system damaged during the contract shall be repaired by the Contractor at no additional cost within 24 hours of notification. If not completed within said limit, the City shall have the authority to complete such work and deduct cost plus 20 percent administration thereof from any moneys due or to become due to the Contractor.

27. CONTRACTOR'S SUPERINTENDENT AND PROJECT MANAGER

The Contractor shall designate in writing and keep on the work at all times during its process a competent, full-time, technically qualified superintendent, who shall not be replaced without written notice to the CITY ENGINEER or his authorized representative except under extraordinary circumstances. The Contractor's superintendent shall be present at the site of the work at all times while work is in progress. The superintendent's sole duties shall be to supervise a full work crew and coordinate activities pertaining any work performed by the Contractor or its subcontractors including, but not limited to street resurfacing operations, street patching, concrete repairs, crack sealing, striping and marking, including traffic control and public notifications. Failure to observe this requirement shall be considered as suspension of the work by the Contractor until such time as such superintendent is again present at the site. The CITY ENGINEER or his authorized representative shall have the right, at any time, to direct a change in the Contractor's superintendent, if the performance is unsatisfactory, as determined by the CITY ENGINEER or his authorized representative, in its sole discretion.

The Contractor shall designate in writing and keep on the work at all times during its process a competent, full-time, technically qualified project manager, who shall not be replaced without written notice to the CITY ENGINEER or his authorized representative except under extraordinary circumstances. The Contractor's project manager shall be responsible for overall administration and coordination of the work including, but not limited to processing of schedules, discussion of change orders and extra work and coordination and distribution of the Daily Reports. The CITY ENGINEER or his authorized representative shall have the right, at any time, to direct a change in the Contractor's project manager, if the performance is unsatisfactory, as determined by the CITY ENGINEER or his authorized representative, in its sole discretion.

28. WORK AFTER REGULAR HOURS

If the Contractor performs any work after regular working hours, or work in excess of 8 hours a day, or on Saturday, Sunday, or any legal holiday and if approved by the City, the Contractor shall pay the City any additional cost incurred by the City as a result of such work. The definition of work after regular working hours outside the work hours

specified in Special Provisions, Section II, Part A-20 Work Hours. Additional costs shall include but not be limited to construction observation and engineering services. Any of the additional costs incurred by the City due to after hours work by the Contractor will be deducted from any monies due or to become due to the Contractor.

29. CONTRACTOR'S DAILY REPORTS

The Contractor shall complete consecutively numbered legible daily reports indicating the number of people working, their names, a narrative description of work performed, the individual locations of the work, serviceable major equipment in use, serviceable major equipment idled, serviceable major equipment down for repairs, sub-contractors working at site, weather conditions, temperature, start time, finish time, and the date. The Contractor's Superintendent shall sign each report. The daily report shall be completed on forms prepared by the Contractor and acceptable to the CITY ENGINEER or his authorized representative. The City will provide a sample format for the daily report at the preconstruction conference. The Contractor shall distribute copies to the Construction Observers and the CITY ENGINEER or his authorized representative at either the conclusion of each workday or prior to the start of work the next day. No progress payments will be processed or made to the Contractor unless all daily reports are completed to the date of submittal of application for payment.

30. REQUEST FOR WORKING DAYS

The Contractor shall notify the CITY ENGINEER or his authorized representative separately in writing within 7 calendar days after the occurrence of a delay, when the Contractor believes that it is entitled to an additional working day per any day the Contractor is prevented from working at the beginning of the workday, for cause defined in Section 8 of the Standard Specifications, or any day the Contractor is prevented from working during the first 5 hours with at least 60 percent of the normal work force for cause as defined in Section 8 of the Standard Specifications. The Contractor's failure to give written notice in the time period specified above shall constitute a waiver of all claims for an additional work day, whether direct or consequential in nature and that day will be counted as a working day. Upon receipt of the Contractor's written request, the CITY ENGINEER or his authorized representative will then make a determination of whether the day or days the Contractor is requesting shall be counted as working days.

31. DEFECTIVE MATERIALS

All materials not conforming to the requirements of these specifications shall be considered as defective, and all such materials shall be removed immediately from the site of the work unless otherwise permitted by the CITY ENGINEER. Upon failure on the part of the Contractor to comply with any order by the CITY ENGINEER made under the provisions of this article, the CITY ENGINEER shall have the authority to remove and replace defective material and to deduct the cost of removal and replacement from any moneys due or to become due to the Contractor.

32. SOUND AND VIBRATION CONTROL REQUIREMENTS

The Contractor shall comply with all local sound control and noise level rules, regulations and ordinances. No internal combustion engine shall operate on the project without a muffler of the type recommended by the manufacturer. Should any muffler or other control device sustain damage, the Contractor shall promptly remove the equipment and shall not return said equipment to the job until the device is repaired or replaced. Said noise and vibration level requirements shall apply to all equipment on the job or related to the job, including, but not limited to truck, transit mixers or transit equipment that may or may not be owned by the Contractor.

33. AIR POLLUTION CONTROL

Contractor shall comply with all applicable air pollution control rules, regulations, ordinances and statutes. All containers of paint, thinner, curing compound, solvent or liquid asphalt shall be labeled to indicate the contents, fully complying with the applicable material requirements.

34. FINAL CLEANING UP

Upon completion of the project and before making application to the CITY ENGINEER for acceptance of the work, the Contractor shall clean all the streets and ground occupied by Contractor in connection with the project, of all rubbish, debris, excess material, temporary structures and equipment, leaving the entire site of the work in a neat and presentable condition.

35. CONTRACTOR'S REQUEST FOR FINAL INSPECTION

When the Contractor believes all the contract work is complete in all parts and requirements, the Contractor will notify the CITY ENGINEER or his authorized representative in writing through a certificate of completion form, which will be provided to the Contractor at the preconstruction conference.

After the City receives the Contractor's certificate of completion, the CITY ENGINEER or his authorized representative will review the Contractor's work for substantial performance with the contract documents. If the CITY ENGINEER or his authorized representative deems the work substantially performed, the Public Works Director will prepare a list of any minor remaining items of work to be completed. The Contractor shall complete all work on the list to the satisfaction of the CITY ENGINEER or his authorized representative within 30 calendar days after the date of the list or the Contractor waives any and all claims to all monies withheld by the City under the Contract to cover the value of all such uncompleted or uncorrected items, including any additional engineering, administration, or inspection costs. If the work was not substantially performed, working days will continue to accrue against the Contractor.

36. RESOLUTION OF PUBLIC WORKS CLAIMS

This contract is subject to the provisions of Article 1.5 (commencing at Section 20104) of Division 2, Part 3 of the California Public Contract Code regarding the resolution of public works claims of less than \$375,000. Article 1.5 mandates certain procedures for the filing of claims and supporting documentation by the contractor, for the response to such claims by the contracting public agency, for a mandatory meet and confer

conference upon the request of the contractor, for mandatory judicial arbitration upon the failure to resolve the dispute through mediation. This contract hereby incorporates the provisions of Article 1.5 as through fully set forth herein.

Claims for \$375,000 or below, as provided by Public Contract Code - §20104 (a)-(d), Application of article; provisions included in plans and specifications:

(a)(1) This article applies to all public works claims of three hundred seventy-five thousand dollars (\$375,000) or less which arise between a contractor and local agency.

(2) This article shall not apply to any claims resulting from a contract between a contractor and a public agency when the public agency has elected to resolve any disputes pursuant to Article 7.1 (commencing with §10240) of Chapter 1 of Part 2.

(b)(1) "Public work" means "public work contract" as defined in Section 1101 but does not include any work or improvement contracted for by the state or the Regents of the University of California.

(2) "Claim" means a separate demand by the contractor for (A) a time extension, (B) payment of money or damages arising from work done by, or on behalf of, the contractor pursuant to the contract for a public work and payment of which is not otherwise expressly provided for or the claimant is not otherwise entitled to, or (C) an amount the payment of which is disputed by the local agency.

(c) The provisions of this article or a summary thereof shall be set forth in the plans or specifications for any work which may give rise to a claim under this article.

(d) This article applies only to contracts entered into on or after January 1, 1991.

Claims for \$375,000 or below, as provided by Public Contract Code - §20104.2 (a)-(f), Claims, requirements, tort claims excluded:

For any claim subject to this article, the following requirements apply:

(a) The claim shall be in writing and include the documents necessary to substantiate the claim. Claims must be filed on or before the date of Final Payment. Nothing in this subdivision is intended to extend the time limit or supersede notice requirements otherwise provided by contract for the filing of claims.

(b)(1) For claims of less than fifty thousand dollars (\$50,000), the local agency shall respond in writing to any written claim within 45 days of receipt of the claim, or may request, in writing, within 30 days of receipt of the claim, any additional documentation supporting the claim or relating to defenses to the claim the local agency may have against the claimant.

(2) If additional information is thereafter required, it shall be requested and provided pursuant to this subdivision, upon mutual agreement of the local agency and the claimant.

(3) The local agency's written response to the claim, as further documented, shall be submitted to the claimant within 15 days after receipt of the further documentation or within a period of time no greater than that taken by the claimant in producing the additional information, whichever is greater.

(c)(1) For claims of over fifty thousand dollars (\$50,000) and less than or equal to three hundred seventy-five thousand dollars (\$375,000), the local agency shall respond in writing to all written claims within 60 days of receipt of the claim, or may request, in writing, within 30 days of receipt of the claim, any additional documentation supporting the claim or relating to defenses to the claim the local agency may have against the claimant.

(2) If additional information is thereafter required, it shall be requested and provided pursuant to this subdivision, upon mutual agreement of the local agency and the claimant.

(3) The local agency's written response to the claim, as further documented, shall be submitted to the claimant within 30 days after receipt of the further documentation, or within a period of time no greater than that taken by the claimant in producing the additional information or requested documentation, whichever is greater.

(d) If the claimant disputes the local agency's written response, or the local agency fails to respond within the time prescribed, the claimant may so notify the local agency, in writing, either within 15 days of receipt of the local agency's response or within 15 days of the local agency's failure to respond within the time prescribed, respectively, and demand an informal conference to meet and confer for settlement of the issue in dispute. Upon a demand, the local agency shall schedule a meet and confer conference within 30 days for settlement of the dispute.

(e) Following the meet and confer conference, if the claim or any portion remains in dispute, the claimant may file a claim as provided in Chapter 1 (commencing with Section 900) and Chapter 2 (commencing with Section 910) of Part 3 of Division 3.6 of Title 1 of the Government Code. For purposes of those provisions, the running of the period of time within which a claim must be filed shall be tolled from the time the claimant submits his or her written claim pursuant to subdivision (a) until the time that claim is denied as a result of the meet and confer process, including any period of time utilized by the meet and confer process.

(f) This article does not apply to tort claims and nothing in this article is intended nor shall be construed to change the time periods for filing tort claims or actions specified by Chapter 1 (commencing with Section 900) and Chapter 2 (commencing with Section 910) of Part 3 of Division 3.6 of Title 1 of the Government Code.

Claims for \$375,000 or below, as provided by Public Contract Code - § 20140.4(a)-(c), pertaining to Civil action procedures; mediation and arbitration; trial de novo; witnesses:

The following procedures are established for all civil actions filed to resolve claims subject to this article:

(a) Within 60 days, but no earlier than 30 days, following the filing or responsive pleadings, the court shall submit the matter to nonbinding mediation unless waived by mutual stipulation of both parties. The mediation process shall provide for the selection within 15 days by both parties of a disinterested third person as mediator, shall be commenced within 30 days of the submittal, and shall be concluded within 15 days from the commencement of the mediation unless a time requirement is extended upon a good cause showing to the court or by stipulation of both parties. If the parties fail to select a mediator within the 15-Day period, any party may petition the court to appoint the mediator.

(b)(1) If the matter remains in dispute, the case shall be submitted to judicial arbitration pursuant to Chapter 2.5 (commencing with Section 1141.10) of Title 3 of Part 3 of the Code of Civil Procedure, notwithstanding Section 1141.11 of that code. The Civil Discovery Act (Title 4 commencing with Section 2016.010 of Part 4 of the Code of Civil Procedure) shall apply to any proceeding brought under this subdivision consistent with the rules pertaining to judicial arbitration.

(2) Notwithstanding any other provision of law, upon stipulation of the parties, arbitrators appointed for purposes of this article shall be experienced in construction law, and, upon stipulation of the parties, mediators and arbitrators shall be paid necessary and reasonable hourly rates of pay not to exceed their customary rate, and such fees and expenses shall be paid equally by the parties, except in the case of arbitration where the arbitrator, for good cause, determines a different division. In no event shall these fees or expenses be paid by state or county funds.

(3) In addition to Chapter 2.5 (commencing with Section 1141.10) of Title 3 of Part 3 of the Code of Civil Procedure, any party who after receiving an arbitration award requests a trial de novo but does not obtain a more favorable judgment shall, in addition to payment of costs and fees under that chapter, pay the attorney's fees of the other party arising out of the trial de novo.

(c) The court may, upon request by any party, order any witnesses to participate in the mediation or arbitration process.

Claims for \$375,000 or below, as provided by Public Contract Code - §20140.6 (a)-(b), Payment on undisputed portion of claim; interest on arbitration awards or judgments:

(a) No local agency shall fail to pay money as to any portion of a claim which is undisputed except as otherwise provided in the contract.

(b) In any suit filed under Section 20104.4, the local agency shall pay interest at the legal rate on any arbitration award or judgment. The interest shall begin to accrue on the date the suit is filed in a court of law.

37. STATUTORY CLAIMS UNDER PUBLIC CONTRACT CODE SECTION 9204

Prior to submitting a Statutory Claim under Public Contract Code Section 9204, the Contractor shall fully comply with specified notice or protest requirements of the Standard Specifications with respect to each and every Statutory Claim.

For the purposes of this Section, Statutory Claim means a separate demand by a contractor sent by registered mail or certified mail with return receipt requested, for one or more of the following: (1) A time extension, including, without limitation, for relief from damages or penalties for delay assessed by a public entity under a contract for a public works project; (2) Payment by the public entity of money or damages arising from work done by, or on behalf of, the contractor pursuant to the contract for a public works project and payment for which is not otherwise expressly provided or to which the claimant is not otherwise entitled; (3) Payment of an amount that is disputed by the public entity.

The terms "Contractor", "Public Entity", "Public Works Project," and "Subcontractor" shall have the meanings as set forth in Public Contract Code section 9204(c)(2) through(5).

Upon receipt of a Statutory Claim, the City shall conduct a reasonable review of the Statutory Claim and, within a period not to exceed 45 days, shall provide the claimant a written statement identifying what portion of the Statutory Claim is disputed and what portion is undisputed. Upon receipt of a Statutory Claim, City and a contractor may, by mutual agreement, extend the time period provided for the City's response. The claimant shall furnish reasonable documentation to support the Statutory Claim.

If the City needs approval from its governing body to provide the claimant a written statement identifying the disputed portion and the undisputed portion of the Statutory Claim, and the governing body does not meet within the 45 days or within the mutually agreed to extension of time following receipt of a Statutory Claim sent by registered mail or certified mail, return receipt requested, the City shall have up to three days following the next duly publicly noticed meeting of the governing body after the 45-day period, or extension, expires to provide the claimant a written statement identifying the disputed portion and the undisputed portion.

Any payment due on an undisputed portion of the Statutory Claim shall be processed and made within 60 days after the City issues its written statement. Failure by the City to respond to a Statutory Claim from a contractor within the time periods described in this Section or to otherwise meet the time requirements of this Section shall result in the Statutory Claim being deemed rejected in its entirety. A Statutory Claim that is denied by reason of the City's failure to have responded, or its failure to otherwise meet the time requirements of this Section, shall not constitute an adverse finding with regard to the merits of the Statutory Claim or the responsibility or qualifications of the claimant.

If the claimant disputes the City's written response, or if the City fails to respond to a Statutory Claim issued pursuant to this Section within the time prescribed, the claimant may demand in writing an informal conference to meet and confer for settlement of the issues in dispute. Upon receipt of a demand in writing sent by registered mail or certified mail, return receipt requested, the City shall schedule a meet and confer conference within 30 days for settlement of the dispute.

Within 10 business days following the conclusion of the meet and confer conference, if the Statutory Claim or any portion of the Statutory Claim remains in dispute, the City shall provide the claimant a written statement identifying the portion of the Statutory Claim that remains in dispute and the portion that is undisputed. Any payment due on an undisputed portion of the Statutory Claim shall be processed and made within 60 days after the City issues its written statement.

Any disputed portion of the Statutory Claim, as identified by the contractor in writing, shall be submitted to nonbinding mediation, with the City and the claimant sharing the associated costs equally. The City and claimant shall mutually agree to a mediator within 10 business days after the disputed portion of the Statutory Claim has been identified in writing. If the parties cannot agree upon a mediator, each party shall select a mediator and those mediators shall select a qualified neutral third party to mediate with regard to the disputed portion of the claim. Each party shall bear the fees and costs charged by its respective mediator in connection with the selection of the neutral mediator. If mediation is unsuccessful, the parts of the Statutory Claim remaining in dispute shall be subject to applicable procedures outside this Section.

For purposes of this Section, mediation includes any nonbinding process, including, but not limited to, neutral evaluation or a dispute review board, in which an independent third

party or board assists the parties in dispute resolution through negotiation or by issuance of an evaluation. Any mediation utilized shall conform to the timeframes in this Section. Unless otherwise agreed to by the City and the contractor in writing, the mediation conducted pursuant to this section shall excuse any further obligation under Section 20104.4 to mediate after litigation has been commenced.

Amounts not paid in a timely manner as required by this section shall bear interest at 7 percent per annum.

If a subcontractor or a lower tier subcontractor lacks legal standing to assert a claim against the City because privity of contract does not exist, the contractor may present to the City a claim on behalf of a subcontractor or lower tier subcontractor. A subcontractor may request in writing, either on his or her own behalf or on behalf of a lower tier subcontractor, that the contractor present a claim for work which was performed by the subcontractor or by a lower tier subcontractor on behalf of the subcontractor. The subcontractor requesting that the claim be presented to the City shall furnish reasonable documentation to support the claim. Within 45 days of receipt of this written request, the contractor shall notify the subcontractor in writing as to whether the contractor presented the claim to the public entity and, if the original contractor did not present the claim, provide the subcontractor with a statement of the reasons for not having done so.

A waiver of the rights granted by this Section is void and contrary to public policy, provided, however, that (1) upon receipt of a claim, the parties may mutually agree to waive, in writing, mediation and proceed directly to the commencement of a civil action or binding arbitration, as applicable; and (2) a public entity may prescribe reasonable change order, claim, and dispute resolution procedures and requirements in addition to the provisions of this section, so long as the contractual provisions do not conflict with or otherwise impair the timeframes and procedures set forth in this section. Nothing in this Section shall relieve the Contractor from its obligations with respect to claims under Section 9-1.07B of the Standard Specifications.

Prior to commencing litigation, if a claim, Statutory Claim, or any portion of a claim or Statutory Claim remains in dispute, the Contractor shall file a Claim as provided in Chapter 1 (commencing with Section 900) and Chapter 2 (commencing with Section 910) of Part 3 of Division 3.6 of Title 1 of the Government Code.

Any claims presented in accordance with the Government Code must affirmatively indicate Contractor's prior compliance with the claims procedures in the Standard Specifications and the previous dispositions above of the claims asserted. Pursuant to Government Code Section 930.2, the one-year period in Government Code section 911.2 shall be reduced to 150 days from either accrual of the cause of action, substantial completion or termination of the Contract, whichever occurs first; in all other respects, the Government Code shall apply unchanged.

The Contractor hereby agrees that it shall have no right to additional compensation, and/or additional contract time for any claim that may be based on any act, failure to act, event, thing or occurrence for which no written Notice of Potential Claim was filed and received by the City within the time limit specified in the Standard Specifications.

38. TRENCHES AND EXCAVATIONS

In accordance with Public Contract Code Section 7104, whenever the digging of trenches or other excavations extend deeper than 4 feet below the surface, the Contractor shall promptly, and before the following conditions are disturbed, notify the City in writing of any: 1) Material that the Contractor believed may be material that is hazardous waste, as defined in Health and Safety Code Section 25117, that is required to be removed to a Class I, Class II, or Class III disposal site in accordance with provisions of existing law; 2) Subsurface or latent physical conditions at the site differing from those indicated; or 3) Unknown physical conditions at the site of any unusual nature, different materially from those ordinarily encountered and generally recognized as inherent in work of the character provided for in the contract. The City shall promptly investigate the conditions, and if it finds that the conditions do materially so differ, or do involve hazardous waste and cause a decrease or increase in the Contractor's cost of, or the time required for, performance of any part of the work, the City shall issue a change order under the procedures described in the Contract. In the unlikely event that a dispute arises between the City and the Contractor regarding whether the conditions materially differ, or involve hazardous waste, or cause a decrease or increase in the Contractor's cost of, or time required for, performance of any part of the work, the Contractor shall not be excused from any scheduled completion date provided for by the Contract, but shall proceed with all work to be performed under the Contract. The Contractor shall retain any and all rights provided either by contract or by law, which pertain to the resolution of disputes and protests between the contracting parties. Where applicable, Contractor shall comply with the trench or excavation permit requirement found in Labor Code Section 6500 and the excavation safety requirements found in Labor Code Section 6705.

39. STREET/PATHWAY CLOSURES

No closure of any street/pathway shall be allowed unless prior written permission is obtained from the CITY ENGINEER. If permission to close a street/pathway is granted then the Contractor is required to notify in writing at least four (4) working days in advance of street/pathway closures, all emergency services, public transportation services, garbage collections services (see Appendix I for schedule), and school bus services, and other agencies as determined by Department of Public Works shall be notified by the contractor in writing of the locations, time and date of the closures. In case of schedule changes, the emergency services, etc., shall be notified by telephone at least two (2) days in advance of the street/pathway closure.

For construction in the vicinity of a school, the Contractor shall contact the West Contra Costa County School District at (510) 231-1100, obtain a school schedule and school circulation plan and incorporate information into the project's schedule and traffic control.

AGENCY

TELEPHONE NO.

City of Pinole Police Department	510-724-8950
City of Pinole Fire Department	510-724-8970
Republic Services	510-262-1610
WestCat (Bus)	510-724-7993
West Contra Costa School District	510-234-3825
Post Master – Pinole	510-741-3056

40. PUBLIC CONVENIENCE AND SAFETY

Attention is directed to Section 7-1.03 and 7-1.04 of the Standard Specifications and the California Manual on Uniform Traffic Control Devices –California MUTCD), published by the Federal Highway Administration (FHWA) and current California Department of Transportation (Caltrans) Supplement(s).

Traffic Control

General: Traffic control shall conform to the California MUTCD.

Minor deviations from the traffic requirements of this section, which do not significantly change the cost of the work, may be permitted upon the written request of the Contractor, if in the opinion of the Engineer public traffic will be better served as the work is expedited. Such deviations shall not be adopted until the Engineer has indicated his written approval. All other modifications will be made by contract change order.

The Contractor shall provide all markers, signs, delineators and crash cushions necessary to ensure the safe passage of traffic through the work zone.

Lane Closure Restriction: The Contractor shall maintain a minimum of one lane of traffic open at all times. The minimum width of a traffic lane shall not be less than 10 feet. Flashing Arrow Boards shall be required.

Flagging: The Contractor shall furnish at his expense and with no extra cost to the City such flagmen and guards as are necessary to give adequate warning to the public that roadway work is underway and of any dangerous conditions. Flagmen shall perform their duties and be provided with equipment in accordance with current applicable provisions of the California MUTCD. The equipment shall be furnished, kept clean and in good repair by the Contractor at his own expense. The Contractor shall furnish, erect, maintain and regularly inspect barricades, lights, signs and other devices as are necessary to prevent accidents and avoid damage or injury to the public. These devices shall conform to the requirements set forth in the current California MUTCD. Any painted graffiti, vandalized, or otherwise damaged signs or equipment shall be immediately replaced.

All street closures, flagging arrangements, detours and traffic signing, including special signs, must be approved by the CITY ENGINEER at least ten (10) working days prior to such closures. Public notification signs shall be approved by the CITY ENGINEER and installed at that time.

Pathway: If work is to be conducted in the vicinity of a pathway, the Contractor shall provide pedestrians with a safe walkway around the construction zone.

Access: The City shall provide the Contractor access to private property when the work requires such access.

Traffic Control Plans: **10 working days** prior to commencement of any work, the Contractor shall submit to the CITY ENGINEER a Traffic Control Plan for all of the various phases of construction. Said plan shall follow the requirements of Section 7-10 of the Standard Specifications and the California MUTCD.

Full compensation for conforming to the requirements of Section 7-10 of the Standard Specifications, the California MUTCD and these Special Provisions not otherwise provided for, shall be considered as included in the prices paid for the various contract items of work, and no additional compensation will be allowed thereof.

41. SANITARY CONVENIENCE

Necessary sanitary facilities for the use of workers on the job shall be provided and maintained in an approved manner by the Contractor, properly secluded from public observation and in compliance with health ordinances, laws and regulations, and their use shall be strictly enforced by the Contractor. Any workman, who fails to use the sanitary facilities as intended, shall be removed from the project site permanently at the sole discretion of the Engineer.

42. CONSTRUCTION YARD

It shall be the Contractor's responsibility to locate any storage sites for materials and equipment needed and such sites either located on public or private property must be approved in advance by the CITY ENGINEER or his authorized representative. Storage sites are to be addressed in the Contractor's SWPPP.

If permission is given to use a City site, the Contractor shall repair any damage as a result of his operations and any repairs will restore the site to **new** and not pre-existing conditions.

When storage sites are to be on located upon private property, the Contractor shall submit to the CITY ENGINEER or his authorized representative, written approval from the record owner authorizing the use of the property by the Contractor. The Contractor shall contact the appropriate City Planning Department to determine if using the site as a stockpile area is allowed. After the project is complete, the Contractor shall supply a written release signed by the owner of record that said property has been satisfactorily restored in order to provide assurance to the City that no later property owner claims will be filed by residents whose property has allegedly damaged by the Contractor and not repaired to their satisfaction. The City will provide the Contractor with a sample release form upon request.

43. EQUIPMENT REQUIREMENTS

Contractor shall furnish all equipment required to safely complete the work and avoid, if possible, conducting any on-site maintenance or repair of said equipment. Necessary minor maintenance may be conducted on site; however, all maintenance and/or repairs shall be completed Monday through Friday between the hours of 7:00 a.m. and 5:30 p.m. Fueling and minor maintenance shall be in compliance with the National Pollutant Discharge Elimination System ("NPDES") requirements.

All equipment shall be in good repair. Equipment from which leaks of oil, hydraulic fluids, coolant, etc., are observed shall be removed from service until the necessary repairs have been completed.

44. PRESERVATION OF PROPERTY

Existing improvements in areas adjoining the locations whereon construction activities are being performed shall be protected from injury or damage resulting from operations of the Contractor. In like manner any building, structure, tree, shrub, or other item in the vicinity of the Contractor's operation, shall be similarly protected and preserved. Vegetation cleared during site preparation shall become the property of the Contractor and shall be removed from the area unless otherwise directed by the CITY ENGINEER.

45. NPDES COMPLIANCE/WATER POLLUTION CONTROL

Water pollution control shall consist of constructing those facilities specified by these Contract Documents, required by law, or as ordered by the CITY ENGINEER or his authorized representative. Said work is intended to provide prevention, control and abatement of water pollution to streams, oceans and other bodies of water. Full compensation for conforming to the requirements in this entire section shall be considered as included in the prices paid for the various contract items of work, and no additional compensation will be allowed therefore.

Housekeeping/Cleanup: The Contractor shall prevent pollution of stormwater from cleanup and disposal operations by using good housekeeping methods. When fluids or dry materials spill, cleanup should be immediate, thorough, and routine. The Contractor shall never attempt to wash them away with water, or bury them. The Contractor shall report significant spills to the appropriate spill response agencies immediately. The Contractor shall recognize that different types of materials have different disposal requirements and follow appropriate practices. The Contractor shall confine non-hazardous debris to dumpsters, covered at night or during wet weather, and taken to a landfill for recycling or disposal. The Contractor shall handle hazardous debris in accordance with specific laws and regulations and dispose of as a hazardous waste. A separate permit is required. Common hazardous debris found on construction sites include, but are not limited to: liquid residues from paints, thinners, solvents, glues, and cleaning fluids, leaching agents from lumber such as formaldehyde, arsenic, copper, creosote and chromium, motor oil, gear oil, antifreeze fluids, brake fluids, etc., unused pesticides.

Sanitary Waste Management: The Contractor shall prevent the discharge of sanitary waste to stormwater by providing convenient, properly located, well maintained facilities. The Contractor shall hire a licensed portable sanitary facility leasing company which will clean the facilities regularly and keep them in good working order. The Contractor shall make sure that portable sanitary facilities are located on relatively level ground away from traffic areas, drainage courses, and storm drain courses, and storm drain inlets. The Contractor shall regularly inspect the facilities for any leaks, and have defective units replaced.

Vehicle and Equipment Management: The Contractor shall use and maintain construction vehicles and equipment in a manner that prevent leaks and spills of fluids, contain wash waters, and control off-site tracking. The Contractor shall not allow leaking vehicles and equipment on-site and shall inspect equipment and vehicles frequently for leaks and repair them immediately. The Contractor shall clean up spills and leaks promptly with absorbent materials, and shall not flush with water.

The Contractor shall fuel, maintain, and repair vehicles and equipment off-site whenever possible, and on-site only in designated areas. The Contractor shall prevent run-on and run-off from designated areas, provide containment devices and cover if necessary.

The Contractor shall wash vehicles and equipment on-site in designated, contained areas, allowing wash waters to infiltrate into the ground. The Contractor shall use phosphate-free, biodegradable soaps, and steam clean in confined areas only.

When not in use, the Contractor shall store equipment and vehicles in designated, contained areas and place drip pans and absorbent material under stored equipment that is prone to leaking and dripping (e.g. paving equipment).

If the Contractor must drain and replace motor oil, radiator coolant, or other fluids on-site, use drip pans or drop cloths to catch drips and spills. The Contractor shall collect all spent fluids, store in separate containers, and recycle whenever possible. Note: For recycling purposes, such liquids must not be mixed with other fluids. Non-recycled fluids generally must be disposed of as hazardous waste.

Surface and Subsurface Water Control: The Contractor shall prevent or reduce the discharge of pollutants to stormwater from surface and subsurface water control operations by using the following methods:

For surface water control operations where the flow is routed to bypass the construction area, establish stable (erosion resistant) conveyance routes for the diverted flow. Trap any significant sediment (e.g., mud) generated by the rerouted flow in a sediment trap, filtering berm, or basin.

In subsurface pumping or other subsurface water control operations where significant amounts of sediment (e.g., mud) are present in the removed water, capture the sediment in a sediment trap, filtering berm, or basin.

If a sediment trap or basin is required for the surface or subsurface water control operations, the facility should be designed such that the sediment is settled or trapped in the facility prior to discharging of the water.

In areas suspected of groundwater pollution, sample the groundwater near the excavation/pumping site and have the water tested for known or suspected pollutants at a certified laboratory.

Any proposed discharge of groundwater may be subject to requirements of the Regional Water Quality Control Board if water is discharged to groundwater or land.

Concrete and Mortar Products: The Contractor shall prevent or reduce the discharge of pollutants to stormwater from concrete waste by conducting washout at appropriate off-site locations, performing on-site washout in a designated area, and training employees and subcontractors.

The Contractor shall store and mix dry and wet materials either off-site or under cover, away from drainage areas.

For washout of concrete trucks the Contractor shall provide appropriate off-site locations or designated contained areas, at least 50 feet away from storm drains, open ditches, streets, or streams.

The Contractor shall prevent run-off from designated washout areas by constructing a temporary pit or bermed area large enough for liquid and solid waste. When concrete sets, breakup and dispose of it in construction fills per direction of soils engineer or as solid waste or recycle.

The Contractor shall inform concrete suppliers of the designated washout locations and disposal sites for concrete and mortar products.

Asphalt and Bituminous Products: Dispose of old asphalt properly. Collect and remove all broken asphalt from the site and recycle whenever possible. Do not dispose of asphalt products into waterways. Follow the stormwater permitting requirements for industrial activities if paving involves an on-site mixing plant.

Construction Water: The Contractor shall reduce or eliminate excessive construction water that may cause erosion and carry pollutants from the site. The Contractor shall:

Store construction water in leak proof tanks, located away from the drainage system. Use construction water conservatively. Whenever possible, dispose of excess water on-site, by allowing it to soak into the ground.

Saw Cut Slurry: Saw cut slurry contains pollutants that must be contained and disposed of properly. The Contractor shall: Prevent saw cut slurry from entering catch basins, manholes and storm drains. Direct slurry into a temporary pit. Dispose of by shoveling or vacuuming the slurry into a truck and removing from the site. Place drip pans or absorbent materials under saw cutting equipment when not in use. Clean up spills with absorbent materials rather than burying. Dispose of absorbent material properly.

Except as otherwise provided in the Standard Specifications or elsewhere in these Special Provisions, full compensation for conforming to the requirements in this section shall be considered as included in the prices paid for the various contract items of work, and no additional compensation will be allowed therefore.

46. SAFETY, SANITARY AND MEDICAL REQUIREMENTS

The Contractor, his employees, his subcontractors and their employees shall promptly and fully carry out the existing safety, sanitary and medical requirements as may from time to time be prescribed by the Industrial Safety Commission and by County or State Health Departments to the end that proper work shall be done and the safety and health of the employees and of the community may be conserved and safeguarded. In case the Contractor does not observe any such regulations and orders, the CITY ENGINEER at the Contractor's expense may enforce them.

47. ELECTRICAL POWER

Unless otherwise provided in the Special Provisions, the Contractor shall provide, at his own expense, all necessary electrical power required for his operations under the contract.

48. PROTECTION OF UNDERGROUND FACILITIES

Attention is directed to the possible existence of underground facilities not known to the owner or in a location different from that, which maybe indicated on the plans, or in these Special Provisions. The Contractor shall take steps to ascertain the exact location of all underground facilities prior to doing work that may damage such facilities or interfere with their service. If the Contractor discovers underground facilities not indicated on the Plans or in these Special Provisions, he shall immediately give the CITY ENGINEER written notification of the existence of such facilities. Such facilities shall be protected from damage as directed by the CITY ENGINEER and the Contractor will be paid for such work as extra work as provided in Section 3-3 of the Standard Specifications.

49. AIR POLLUTION CONTROL

Section 7-8.2, "Air Pollution," of the Standard Specifications is supplemented by the following:

The Contractor shall comply with all air pollution control rules, regulations, ordinances and statutes which apply to any work performed pursuant to the contract, including any air pollution control rules, regulations, ordinances and statutes specified in Section 11017 of the Government Code.

In the absence of any applicable air pollution control rules, regulations, ordinances or statutes governing solvents, all solvents including, but not limited to the solvent portions of paints, thinners, curing compounds, and liquid asphalt used on the project shall comply with the applicable material requirements of the Bay Area Air Quality Management District. All containers of paint, thinner, curing compound or liquid asphalt shall be labeled to indicate that the contents fully comply with said requirements.

50. PROJECT APPEARANCE

The Contractor shall maintain a neat appearance to the work. **The project streets and any streets adversely affected by the Contractor's activities shall be kept clean at all times. Contractor shall have access to a vacuum sweeper at all times.**

In any area visible to the public, the following shall apply: When practicable, broken concrete and debris developed shall be disposed of concurrently with its removal. If stockpiling is required, the material shall be placed in an area, which does not impact, public or private landscaping or irrigation and the material shall be removed or disposed of daily.

Should the Contractor appear to be neglectful or negligent in maintaining a clean project site, the CITY ENGINEER may direct the Contractor's attention to the existence of such condition(s). The Contractor shall provide all necessary measures immediately, at his expense. If attention is directed to the existence of such condition(s), and the Contractor fails to provide an appropriate remedy, any expense incurred by the City for providing correcting actions may be deducted from the pay estimates and the total contract price for the work, including a Fifty Dollar (\$50.00) penalty per calendar day the condition(s) exist from date of notification.

Full compensation for conforming to the provisions in this section not otherwise provided for shall be considered as included in prices paid for the various contract items of work involved, and no additional compensation will be allowed therefore.

51. WORK HOURS

The Contractor's working hours shall be limited to the hours between 7:00 a.m. and 5:00 p.m., Monday through Friday, excluding those City holidays listed in Section II.A.5 of the Special Provision on page SP-2. Allowable hours for lane closures will vary based on work location and will be detailed in the Special Provisions. Deviation from normal working hours will not be allowed without prior consent of the CITY ENGINEER.

In the event work is allowed by the CITY ENGINEER outside of the normal working hours, at the request of and for the benefit of the Contractor, inspection service fees shall be levied against the Contractor at a rate of \$165.51 per hour or actual costs plus 10% if a consultant is utilized, plus travel time where applicable. The above charge may also be levied if inspection services are deemed necessary by the CITY ENGINEER as a matter of public safety or to otherwise ensure the quality of the work.

If work is permitted after sunset, the Contractor shall provide, at its expense, adequate light for proper prosecution of the work for the safety of the workmen and the public, and for proper inspection.

52. CONSTRUCTION STAKING

Contractor shall be required to provide any and all necessary construction staking required to construct the project. The Contractor shall be responsible for hiring a licensed land surveyor or a civil engineer authorized to survey, to provide a layout and construction staking of all improvements being constructed as part of this project. The contractor shall provide the city with cut sheets at least 24 hours prior to proceeding with new work.

Payment

Full Compensation for this item shall be considered included in the various bid items of this project and therefore, no additional compensation shall be allowed.

END OF SECTION

PROJECT SPECIAL PROVISION (SECTION II)

The Special Provisions and Technical Specifications contained herein have been prepared by or under the direction of Rich Souza, a registered professional engineer.



Rich Souza

Date: 05.03.21

1. GENERAL

Order of Work - Order of work shall conform to the provisions of Section 6-1, "Construction Schedule and Commencement of Work," of the Standard Specifications and these Special Provisions. The Contractor shall conduct his operations so as to cause minimum obstruction and inconvenience to traffic, schools and residences.

Scheduling, Notifications and Posting: Within five (5) calendar days of notification of award of the Contract, the Contractor shall prepare and submit a detailed work schedule meeting the following criteria to the CITY ENGINEER or his designated representative: **The Notice to Proceed will not be issued until the schedule has been submitted in a substantially complete form. Should the Contractor not submit the project schedule within five (5) calendar days, then the City may begin deducting working days from the Contractor.**

Said schedule must show the dates of the expected start and completion of all the various bid items, including but not limited to the location of where the Contractor will be performing the work, all tasks that will be performed that day, and the estimated amount of time each working day that it shall take the Contractor to complete the work. The schedule shall be in the form of a Gant/Bar Chart and a Critical Path Method schedule, and both shall be in sufficient detail to show the chronological relationship of all activities of the project including, but not limited to, estimated starting and completion dates of various activities, scheduling of equipment and procurement of materials. The construction schedule shall reflect completion of all work under the Contract within the specified time and in accordance with the contract documents.

The Contractor shall obtain a City paving and base map and submit five (5) copies of overall map schedules, on which streets are color coded to clearly show the relationships between the different scheduled weeks, one for each for overlay. On separate maps, street segments shall be color coded by day for the full upcoming week to provide active map schedules, one for each, showing overlay and cold milling. The overall map schedule showing all street segments color coded by week shall be provided as part of schedule submittals. Both the active and overall schedules shall be provided as part of initial

schedule submittal and shall be updated throughout the term of the project. These maps shall be updated weekly and shall be transmitted over the weekend such that the City has color documents on Monday morning.

An active schedule shall also be prepared as a list showing street segments for paving and edge grinding a week ahead, which shall be prepared on a daily basis as changes occur. The Contractor's designated respective foreman or project supervisor shall contact the contractor's office near the end of the workday and coordinate edits of the list of street segments such that the list can be hand-delivered, faxed or e-mailed to the City by 5:00 p.m. the same day. Failure to provide the updated list as specified will be cause for the Engineer to limit the work to street segments on the previous list.

The Contractor shall provide a copy of the active schedule list in a format and on a day acceptable to the CITY ENGINEER or his authorized representative to be considered the advance weekly schedule. The City will then forward these schedules to the local cable station that will televise in order to further notify the residents. The City will provide the Contractor the exact format of the weekly schedule at the preconstruction conference. The Contractor shall submit these schedules at least 1 week prior to the occurrence of the work. The Contractor shall be responsible for preparing any modifications to these schedules on a weekly basis.

During the conference between the Contractor and the CITY ENGINEER or his authorized representative, the work schedule will be discussed and modified, if necessary, by mutual agreement. Should it become necessary for the City to temporarily delay the work schedule agreed upon during the scheduling conference, every effort will be made to permit a new work schedule at the time most convenient to the Contractor, thus permitting the project to proceed with the shortest intramural movement of the equipment within the project.

The Contractor shall submit requests for changes in the schedule in writing to the CITY ENGINEER or his authorized representative for approval at least 2 working days prior to the scheduled work affected.

The Contractor shall prepare a typewritten copy of the weekly schedule in a format acceptable to the CITY ENGINEER or his authorized representative.

The City of Pinole strictly adheres to a policy whereby property owners are kept fully informed as to potential inconveniences caused by construction activities within the City. Every effort is made to minimize these inconveniences. Toward this goal, the Contractor will be required to thoroughly schedule his work and to share that schedule with the property owners affected by the project. This is accomplished using door hangers placed 1 week and 48 hours prior to the planned activity. The door hanger shall contain the information as determined by the City at the Pre-construction meeting. In order to avoid unnecessary problems through the construction period, it is mandatory that a detailed schedule be prepared which addresses all of the known controls, which must be scheduled around. .

The Contractor shall distribute to each residence and business a written notice (door hanger), to be submitted to and approved by the Engineer, a minimum of 48 hours prior to placing the notices. For apartment buildings, condominium, or townhouse, the Contractor shall notice each individual unit within the complex. The Contractor shall contact the property manager to gain access. The notice shall state the type of work and the approximate time the work is anticipated. All notices shall include the Contractor's

telephone number to address questions. The Contractor shall be responsible for re-notification of all affected property owners should the project be delayed.

MEASUREMENT AND PAYMENT

Full compensation for "Scheduling, Notifications and Posting" shall include full compensation for furnishing all labor, materials, tools, equipment, and incidentals for doing all work complete as specified herein and shall be considered as included in the contract prices for the various items of work and no additional compensation will be made therefor.

2. CONSTRUCTION METHODS

General: The Contractor shall contact the affected utility companies for information regarding identification, location, and depth of underground utilities.

Preservation of Property: Existing improvements in areas adjoining the property whereon demolition and removal is being performed shall be protected from injury or damage resulting from operations of the Contractor and the Contractor shall be responsible for such damage. In like manner any building, structure, tree, shrub, or other item in the area where demolition and removal are being performed shall be similarly protected and preserved.

Dust Control: The Contractor shall provide such dust laying equipment and methods as may be required to protect adjacent property from annoyance or damage from dust caused by his operations, and failure to control such dust shall be cause for the CITY ENGINEER to stop the work until said dust is controlled, and the Contractor shall have no recourse to collect from the City for any loss of time or expense sustained by him due to such suspension of work.

Removal of Traffic Stripes and Pavement Markings

The Contractor shall remove pavement striping, markings, and raised markers in conflict with roadway improvements and as indicated in the Plans and as described in this Section.

The pavement markings include lane lines, arrows, symbols, and numerals shall be removed by grinding or as approved by the Engineer. The Contractor shall use a grinder that minimizes damage to the existing asphalt but obliterates the marking. This work shall minimize the generation of dust. Should the Contractor damage the asphalt, he or she shall restore the surface to the satisfaction of the Engineer at no additional cost.

When the presence of asbestos, lead paint or hazardous substances are not shown on the plans or indicated in the specifications and the Contractor encounters materials which the Contractor reasonably believes to be asbestos or a hazardous substance as defined in Section 25914.1 of the Health and Safety Code, all such removal of asbestos or hazardous substances including any exploratory work to identify and determine the extent of such substances will be included in the lump sum price for this contract.

Selected Materials: Existing materials excavated within the project limits that meet the specifications for trench backfill, topsoil, or other selected materials may be used to fulfill all or a portion of the requirements for such materials. No additional compensation will be allowed for excavation, stockpiling, overhaul, or placing selected materials encountered in the excavation.

Surplus Materials: The Contractor shall furnish written consent from the owner of the property where it is intended to dispose of the surplus material. Surplus excavation shall become the property of the Contractor.

MEASUREMENT AND PAYMENT

Full compensation for "Construction Methods" shall include full compensation for furnishing all labor, materials, tools, equipment, testing of hazardous materials, removal and disposal of hazardous materials, and incidentals for doing all work complete in place for preservation of property, dust control, selected materials, hazardous materials, and surplus materials as specified herein and shall be considered as included in the contract prices for the various items of work and no additional compensation will be made therefor.

3. MOBILIZATION

General: Mobilization shall conform to the provisions in Section 9-1.16(D), "Mobilization," of the State Standard Specifications, and shall consists of preparatory work and operations including, but not limited to, those necessary for the movement of personnel, equipment, supplies incidental to the project site, for the establishment of all staging areas and other facilities necessary for work on the project and for all other work and operations which must be performed or for project costs incurred prior to beginning work on the various Contract items. Mobilization shall include obtaining insurance and bonds, obtaining and paying for all permits by other agencies if applicable, furnishing temporary construction utilities, installing construction and other construction facilities all as required for the proper performance and completion of the work.

The work of this bid item also includes demobilization. Demobilization shall include final cleaning and restoration of the job site, removal of all temporary facilities and equipment from the work area, disconnection of the temporary construction utilities and turnover of project to the City.

MEASUREMENT AND PAYMENT

Full compensation for "Mobilization" shall include full compensation for furnishing all labor, materials, tools, equipment, and incidentals including providing bonds, insurance, financing, moving equipment to and from the job site and preparing an approved work schedule as specified herein and shall be considered as included in the contract prices for the various items of work and no additional compensation will be made therefor.

4. PROTECTION AND RESTORATION OF EXISTING IMPROVEMENTS

General: Except as may otherwise be provided in specific instances, nothing in the Contract shall be construed as vesting in the Contractor any property right in any material, article or structure existing at the time of award of Contract within the area in which the work is to be done; or in any material or article subsequently furnished for the work by the Contractor after having been accounted for on an approved estimate supporting the Contractor's demand for payment as provided in Section 9 of the Standard Specifications. In the latter event any such material, article, structure or work shall become the property of the agency after being so accounted for.

The Contractor shall maintain all existing roadside mailboxes and signs including, but not limited to directional, warning, advisory, regulatory, bus stop, and street markers, in an erect

and functional position and conditional all times during the construction period in temporary locations as designated by the CITY ENGINEER or his authorized representative. The Contractor at no cost to the Agency shall replace any of these facilities, which are damaged or lost.

Contractor shall submit video documentation with a log of existing damages prior to commencing with work. Should a resident claim existing improvements were damaged by construction, and Contractor did not confirm status per above, Contractor shall restore existing improvements at no cost to the City.

When an interfering portion of a privately owned sprinkler system is removed from the public right of way, heads and other salvable material shall be carefully removed and placed on the private property. The Contractor shall remove any of the materials not wanted by the owner of the private property from the site. Removal, repair, or capping shall be as directed by the CITY ENGINEER or his authorized representative.

Contractor shall confirm operational status of all affected irrigation with inspector and resident prior to commencing work. Should resident claim their system was damaged by construction, and Contractor did not confirm status per above, Contractor shall restore system to operation at his own cost.

MEASUREMENT AND PAYMENT

Full compensation for "Protection and Restoration of Existing Improvements" shall include full compensation for furnishing all labor, materials, tools, equipment, and incidentals for doing all work complete as specified herein and shall be considered as included in the contract prices for the various items of work and no additional compensation will be made therefor.

5. CLEARING AND GRUBBING

General: The Contractor shall clear and grub along edge of pavement as necessary to cold mill and resurface per plan. In addition, the contractor shall clear and grub the area to receive new curb, gutter and sidewalk. All clearing and grubbing work shall be done in accordance with Section 17-2, "Clearing and Grubbing", of the State Standard Specifications, these Specifications, and as directed by the Engineer.

Execution: Clearing and grubbing shall consist of (but not limited to) removing and disposing of vegetable growth and deleterious, including roots, grass, weeds, rocks, as well as pavement sawcut, and all other objectionable material as required to construct the improvements, as shown on the Plans and as specified in these Specifications.

All resulting plants, shrub, and other excavation material shall be disposed of outside the street right-of-way as required in Section 7-1.13 of the Standard Specifications.

Prior to starting clearing and grubbing operations, the Contractor shall inform the Engineer of the intended limits of his/her clearing and grubbing operations and shall obtain the Engineer's approval on such proposed limits. The Contractor shall not clear and grub any area not essential to their construction obligations and protect from injury or damage resulting from his/her operations all vegetation, facilities, or improvements, which are to remain. All edges of existing paving to remain shall be sawcut in a neat, clean manner.

MEASUREMENT AND PAYMENT

The lump sum cost paid for "Clearing and Grubbing" (Bid Item A-9) includes full compensation for furnishing all labor, materials, tools, equipment, and incidentals, and for doing all the work involved in clearing and grubbing, including the removal and disposal of the resulting material, as specified in the Standard Specifications and these Specifications, and as directed by the Engineer.

6. UNCLASSIFIED EXCAVATION

General: Unclassified excavation shall consist of all excavation, including roadway, bituminous pavement associated and concrete pavement, curb, sidewalk, gutters, cross gutters, driveways and access ramps.

Execution: *Bituminous Pavement* shall be removed to neatly sawed edges. Saw cuts shall be to a minimum depth of 3 inches. Where bituminous pavement adjoins a trench, the edges adjacent to the trench shall be saw cut to neat straight lines before permanent to ensure that all areas to be paved are accessible to the rollers used to compact the subgrade or paving materials. Removal at flow line areas shall include restoring pavement surface to flow line grade based on surrounding conditions.

Roadway base and surfacing shall be removed as required for the roadway in accordance with Section 19, "Earthwork," of the Standard Specifications and these Specifications, as shown on the Plans, and as directed by the Engineer. This bid item also includes removal of base rock as required for the improvements.

The Contractor, at his expense, shall repair materials to be salvaged that are damaged as a result of the Contractor's operations to the satisfaction of the Engineer.

Removal of Concrete Curb, Gutter, Sidewalk Cross Gutters, Driveways and Access Ramps: Concrete shall be removed to neatly sawed edges with saw cuts made to a minimum depth of 1.5 inches. Concrete sidewalk, access ramps or driveways to be removed shall be neatly sawed in straight lines either parallel to the curb or at right angles to the alignment of the sidewalk. No section to be replaced shall be smaller than 30 inches in either length or width. If the saw cut would fall within 30 inches of a construction joint, functional weakened plane joint, expansion joint or edge, the concrete shall be removed to the joint or edge. In any case, the saw cut shall be made in and along a score mark if within the 30-inch zone. Curb and gutter shall be sawed to a depth of 1.5 inches on a neat line at right angles to the curb face.

Existing concrete to be removed shall be completely removed and disposed of in conformance with the provisions in Section 15-3, "Concrete Removal" and Section 14-10, "Solid Waste Disposal and Recycling", of the Standard Specifications and these Specifications, as shown on the Plans, and as directed by the Engineer. This bid item also includes removal of base rock as required for the improvements.

MEASUREMENT AND PAYMENT

Full compensation for "Remove Asphalt Concrete & Base" of the various types shall include full compensation for furnishing all labor, materials, tools, equipment, and incidentals and for doing all the work complete in place, including sawcutting, demolition and removal of asphalt and aggregate base, hauling, recycling, disposal, cleanup and other incidental work, as shown on the Plans, as specified in the Standard Specifications and these Specifications, and as directed by the Engineer and shall be included in the cost of the various bid items.

The contract price paid per square foot for "Remove Concrete & Base" (Bid Item 24) of the various types sidewalk, pus pad, driveway, curb, and gutter shall include full compensation for furnishing all labor, materials, tools, equipment, and incidentals and for doing all the work involved in removing concrete, complete in place, including sawcutting, demolition and removal, hauling, recycling, disposal, as shown on the Plans, as specified in the Standard Specifications and these Specifications, and as directed by the Engineer.

The provisions of Section 9-1.06B Increases of More Than 25 Percent and Section 9-1.06C Decreases of More Than 25 Percent, of the Standard Specifications shall not apply. No adjustment in the respective contract unit price for "Remove Asphalt Concrete & Base" shall be made for increases or decreases of more than 30 percent of the quantities set forth in the Schedule of Bid Prices.

Payment: Full compensation for unclassified excavation shall be included in the applicable price bid for the construction items requiring removal, and no additional payment shall be made therefor. Payment for access ramp construction, reconstruction or modification shall be included in the unit price bid, including the removal of existing improvements, truncated dome, retaining curb, restoration of existing landscaping and irrigation system, and no additional payment shall be made therefor.

7. APPURTENANT WORK

All items in the Bid Schedule are for construction completed in place, including all incidentals, appurtenant work and materials necessary for the satisfactory completion of the work. Full payment shall be considered as the bid prices for the items of work, and no additional compensation will be made therefore.

8. COMPACTION TESTING

The City of Pinole will provide all necessary soils compaction testing for this contract, except for work that has to be redone as noted below.

The Contractor's requests for compaction testing shall be made to the CITY ENGINEER or his authorized representative a minimum of 2 working days prior to the time required for such work.

The Contractor, at his expense, shall excavate the holes for all of the tests, backfill the holes and compact this backfill, and pave the surface, if required, after the test.

Compaction tests on the subgrade, which meet the specified requirements, will be at the City's expense. All compaction tests, which do not meet the specified compaction requirements, will be at the Contractor's expense, with no re-compensation therefore.

9. FURNISH AND APPLY WATER

Furnishing and applying water shall be considered as included in the lump sum and unit prices paid for the various bid items requiring water, and no additional compensation will be allowed therefore.

Should the Contractor require water for construction operations, such as for compaction and dust control, he shall apply for a water meter from, and follow the requirements of, the East Bay Municipal Utility District.

10. CONSTRUCTION PHASING AND TRAFFIC CONTROL

General:

Construction Phasing Plan (CPP) - The Contractor is required to submit a Construction Phasing Plan and receive approval by the Engineer prior to starting on-site activities, as described herein and in the Special Provisions.

Contractor shall provide traffic control within the work zone throughout the project as needed for the various traffic situations and street configurations in full conformance with the "California Manual on Uniform Traffic Control Devices 2014 ((Federal Highway Administration (FHWA) Manual of Uniform Traffic Control Devices (MUTCD) 2009, as amended for use in California)" herein after referred to as Traffic Control Manual. The Traffic Control Manual may be obtained online at <http://www.dot.ca.gov/trafficops/camutcd/camutcd2014rev2.html>

Submittals:

Construction Phasing Plan (CPP) - The Contractor is required to submit a Construction Phasing Plan and receive approval by the Engineer prior to starting on-site activities. The Contractor's CPP shall take into consideration the roadway restrictions described below and roadway restrictions in the proposed and approved TCPs. The Contractor shall submit revised CPP(s) for any changes to the Construction Phasing Plan, including any change to the TCPs. The CPP shall be submitted within 10 working days following issuance of the Notice to Proceed (NTP), and at least 10 working days prior to the proposed start of on-site work, for review and approval by the Engineer. The City of San Pinole reserves the right to modify any portion of the plan.

Traffic Control Plans (TCPs) - The Contractor is required to submit Traffic Control Plans for each stage of construction and receive approval by the Engineer prior to starting work on an upcoming stage. The Contractor's TCPs shall take into consideration the roadway restrictions described below. The Contractor shall submit in writing a complete traffic control plan (1"=40' scale min. drawing) to the City Engineer within fifteen (15) working days after the effective date of the Notice to Proceed. The traffic control plan shall include all locations, which involve all project improvements and shall indicate each stage of work, signage, flagman, detour routes, and any other pertinent information. It shall also show all proposed traffic controls to scale (e.g., widths and lengths of temporary barriers, lane and sidewalk widths, and roadway widths). The traffic control plan shall be reviewed and approved by the Engineer before the Contractor shall be allowed to begin work. The City of Pinole reserves the right to modify any portion of the plan.

The traffic control plan shall include a pedestrian detour plan to route pedestrian and bicycle traffic around the active work area affecting access. Signage must be installed to direct pedestrians to cross at adjacent intersections/crosswalks or on the same side of the street in high pedestrian traffic areas and indicate the portions of sidewalk that will be closed to pedestrian traffic, as directed by the Engineer. Contractor shall maintain ADA compliant pedestrian access to adjacent businesses and residents during all phases of construction.

Execution:

Construction Phasing Plan (CPP) - The Construction Phasing Plan (CPP) as described in the Contract Documents, including herein and in the Special Provisions shall include sufficient detail to describe how the Contractor intends to phase the work over the course of the entire project. Details for each phase of construction shall be included in the CPP. Any change to the CPP shall be reviewed and approved by the Engineer prior to implementation by the Contractor. The City of Pinole reserves the right to modify any portion of the plan. The Contractor shall not proceed with any on-site activities until the CPP is approved by the Engineer, or unless otherwise directed by the Engineer.

At a minimum, the CPP shall include the following information:

- One of the Contractor's first on-site activities shall be to place portable changeable message sign (PCMS) boards in coordination with the Engineer. A minimum of 2 PCMS boards shall be placed for each phase and/or subphase. All of these PCMS boards shall be in placed at least 5 working days prior to the start of the first construction phase. Refer to the "Traffic Control Plans (TCPs)" subsection below for more information.
- Proposed construction sequencing, including limits of work, type(s) of barriers to separate work areas from public areas, work hours, durations of each phase, and an overall project schedule showing how each phase is related to adjacent phases. Barriers that separate pedestrians from vehicle traffic lane(s) shall be water-filled with a minimum height of 30 inches, unless otherwise approved by the Engineer.
- Layout of the work areas, including materials storage, parking for Contractor's vehicles, and ingress and egress to/from the work areas via nearby streets, which should take into account sight lines for pedestrians, bicyclists, and motorists. These areas shall be sized as small as possible.
- Construction employees shall not occupy on-street public parking spaces. The Contractor shall provide off-street (on-site) parking accommodations for their employees. Contractor's employees shall find other alternatives to driving singly to the site.
- Proposed pedestrian, bicycle, and motor vehicle access ways around the work areas for each construction phase, including pedestrian circulation routes, temporary curb ramps, crosswalks, and other pedestrian facilities; bicycle circulation routes and treatments around the construction areas; and quantity, width, and direction of traffic lanes.
- General detour plans, if applicable, for any condition that would be expected to affect traffic.
- Existing waste and recycling operations must continue uninterrupted during the time of this Contract. The Contractor must schedule and perform all Work in such a way to avoid conflicts with ongoing waste and recycling operations. Provide a minimum of 25 contiguous feet of unobstructed curb and sidewalk space per City block face, on a daily basis, in order to accommodate the City's need to pick up curbside waste bins/carts for residents and businesses within the Project limits. Provide manual assistance to move and/or relocate waste bins/carts as necessary, on a daily basis, if construction operations affect accessibility of waste bins/carts.

- Locations of all driveways, doors, and gates that front the sidewalks and roadways within each of the project phases. Maintain continuous access to these access points to the maximum extent possible. Coordinate in advance with the Engineer if temporary closure(s) of such access point(s) is necessary.
- Locations of temporary and/or relocated bus stops, if applicable.
- Locations of loading/staging areas for construction vehicles, which should be located inside the work area. Trucks cannot stage along adjacent frontages or other streets, in loading zones outside the site frontage, or double-park or block travel lanes. Trucking companies shall be made aware of staging in only the approved areas and turned away if there is no staging area available upon their arrival.
- Temporary emergency accessways for emergency vehicles (fire trucks, police, ambulance, etc.) that will remain clear of work areas; construction equipment, materials, and vehicles; and personnel.

The Contractor should be aware that businesses within the project limits will remain open during the duration of construction and shall plan work accordingly in order to minimize disruption to ongoing business activities.

In general, paving work shall be performed in phases so that traffic disruption is minimized. Final pavement markings shall be installed only after all paving activities are complete. The Contractor shall furnish and install temporary pavement markings, as described in Section 12-6 of the Standard Specifications, prior to opening each phase of work. The intent of this requirement is to have clean and fresh final pavement markings at the completion of the Project.

Portland Cement Concrete (PCC) pavement shall not experience any vehicular loading prior to meeting the requirements to open the pavement for traffic, as described in the Contract Documents, Section 40 "Concrete Pavement" of the Standard Specifications, and as directed by the Engineer.

The Contractor may only work in one phase at a time. Boundaries for each phase are not required to be contiguous though. Refer to the Special Provisions for additional information/requirements on construction phasing. The Contractor will not be allowed to proceed to the next phase unless the work of the previous phase is accepted by the Engineer. The Contractor shall provide a minimum of 10 working days advance notice to the Engineer of the planned completion of each phase. Acceptance of the work of each phase by the Engineer does not relieve the Contractor of his/her responsibility to provide temporary and/or permanent improvements suitable for use by the general public in accordance with all applicable laws, regulations, codes, requirements, and standards of practice.

Traffic Control Plans (TCPs) - Extensive traffic signage, e.g., warning signs and detour signs, are required. Contractor shall be responsible for placing all barricades for perimeter street closures as required. Per Section 501.10 – Traffic Control of the General Provisions, at main entry and exit points of each work location, the Contractor shall provide a 30" x 30" sign advising the public of the anticipated period of time that traffic delays may be anticipated. This sign will also include name and telephone number of the Contractor along with starting and completion dates of the contract. Sign shall be erected 7 days in advance of any work.

If during construction activity, the closure of one lane of traffic is necessary, the contractor shall utilize all necessary construction zone signage, including changeable message signs, during the lane closure. **The Contractor shall assume for the purposes of bidding that two changeable message signs will be deployed concurrently beginning at least one week prior to the commencement of construction activity until project completion.**

The Contractor shall be responsible for posting "No Parking" signs a minimum of four days in advance of concrete work, paving operations, earthwork operations, and/or planning work so as to comply with the City's construction notification requirement of 72 hours. Cones shall not be used as barricades. "No Parking" signs may be obtained from the City at no cost to the Contractor. "No Parking" signs must be posted every twenty (20) feet. The "No Parking" signs shall be updated as necessary. The Contractor shall check and maintain (e.g., re-install missing signs, reposition displaced barricades, etc.) postings on a regular basis prior to start of work.

A minimum of one (paved) traffic lane, not less than 11 ft. wide, shall remain open for use by public traffic during construction operations. When construction operations are not actively in progress, not less than two such lanes shall be open to public traffic. The Contractor may be allowed to close residential streets if approved in writing in advance by the Engineer. No work that interferes with public traffic shall be performed between 5:00 p.m. and 7:00 a.m.

No lane closures shall be permitted on the following Major Streets Monday through Friday between 7:00-9:00 AM and 4:00-6:00 PM, unless approved in advance by the Traffic Engineer if it can be explained why such closure cannot be reasonably avoided.

If traffic is to be detoured over a centerline or detoured in advance of the work, detour plans must be submitted to and approved by the Engineer prior to starting work. Police, Fire and Public Works Department shall be notified at least two days in advance of any work which will interfere with the normal flow of vehicular or pedestrian traffic. Intersection closure may only occur if the two adjacent intersections remain open, unless otherwise approved by the Engineer. The Contractor shall coordinate his traffic control/diversion plan with City personnel, a minimum of 3 weeks prior to starting work, to assure that traffic is diverted in a safe and convenient manner.

At the end of each day's work, and at other times when construction operations are suspended, all equipment and other obstructions shall be removed from that portion of roadway open for use by public traffic. No longitudinal joint shall be left during non-working hours.

Where existing road signs are in conflict with the proposed work, the Contractor shall relocate such signs to temporary or permanent locations as directed by the Engineer.

If it becomes necessary, in the opinion of the City Engineer, to properly move traffic through the construction area, flagmen shall be present to slow down and reroute traffic, in which case flagmen shall be on duty the entire period the roadway is constructed. Where flagmen are not visible to each other, additional flagmen shall be added as required by the Engineer or the Contractor shall use radios.

Contractor shall take all necessary measures to obtain a normal flow of traffic to prevent accidents and to protect the work throughout the construction stages until completion of the work. The Contractor shall make the necessary arrangements to provide and maintain

barriers, cones, guards, barricades, and construction warnings and regulatory signs. The Contractor shall take measures necessary to protect all other portions of the work during construction and until completion, providing and maintaining all necessary barriers, barricade lights, guards, temporary crossovers and watchmen.

In addition to the foregoing traffic control and safety measures, the Contractor shall undertake immediately to implement any measures requested by the Engineer, as they deem necessary to ensure the proper flow of traffic and the protection of the public and the safety of the workers. The Contractor shall maintain at all times the ability to respond to calls from the City of Pinole Police and Fire Departments during non-working hours to replace or provide additional traffic control or safety devices as shall be required by the Police Department.

Truck routes must be approved by the City's Traffic Engineer prior to start of work.

Personal vehicles of the Contractor's employees shall not be parked within the area of work.

Notwithstanding the above, the Traffic Engineer reserves the right to review and comment on each individual traffic control plan based on its own merits. Routine maintenance, inconvenience to construction method or schedule, or adverse impacts on cost of work will not generally be accepted as grounds for exceptions.

Start of work shall be no earlier than 7:00 a.m. No work process, including starting, warm up, and delivery of equipment, shall be done outside of work hours. The use of vehicle horns to alert residents to move their vehicles out of the construction zone is not permitted. The Contractor should attempt to locate vehicle owners by knocking on doors. If Contractor violates these provisions, a fine of \$1,000 will be assessed for the first violation, \$5,000 for the second and \$10,000 for the third.

The full width of the traveled way shall be open for use by public traffic on Saturdays, Sundays and designated legal holidays, and when construction operations are not actively in progress, unless specified otherwise.

Minor deviations from the requirements of this section concerning hours of work may be permitted upon the written request of the Contractor if in the opinion of the Engineer, public traffic will be better served and the work expedited. Such deviations shall not be adopted until the Engineer provides written approval.

The traffic control system shall consist of closing traffic lanes in accordance with the Traffic Control Manual. Signs and other devices for the traffic control system shall conform to the Traffic Control Manual.

If any component in the traffic control system is damaged, displaced or ceases to operate or function as specified, from any cause during the progress of the work, the Contractor shall immediately repair said component to its original condition or replace said component and shall restore the component to its original location.

Lane closures may be made for work periods only. At the end of each work period, all components of the traffic control system shall be removed from the traveled way, shoulder and auxiliary lanes. If the Contractor so elects, said components may be stored at selected central locations approved by the Engineer within the limits of the public right-of-way.

Sufficient barricades and flashing lights shall also be placed to supplement all traffic signs used to divert and control traffic. Signs and barricades shall be checked periodically every day and replaced or repaired as necessary. Any hazardous conditions shall be immediately eliminated.

If the project is left open overnight, it shall be graded in such a way that pedestrians and vehicles can safely pass through the project area. Temporary concrete, asphalt, or wood ramps shall be installed where feasible, as determined by the project engineer, or pedestrians and vehicles routed around the project area in accordance with the approved traffic control plan.

No vehicular traffic shall be allowed on a tack coat.

Cleanliness is extremely important. Dust producing conditions shall be eliminated as soon as they are created.

Access and Egress

Work shall be accomplished in such a manner as to provide access to all intersecting streets and adjacent properties whenever possible. The Contractor shall endeavor to cooperate with all business owners and residents occupying properties fronting on the streets in the matter of access and egress.

Contractor shall maintain a clear and accessible pedestrian corridor around the work site to the extent feasible.

An alternate circulation path shall be provided whenever the existing pedestrian access route in the public right-of-way is blocked by construction, alteration, maintenance, or other temporary conditions. Where possible, the alternate circulation path shall parallel the disrupted pedestrian access route, on the same side of the street.

Residential Pedestrian Traffic Control (Type A)

Pedestrian corridor shall be a nominal width of 5 feet whenever feasible, and shall conform to ADAAG guidelines. It shall not be less than 48-inches wide at single point of contact or obstruction. The Contractor shall work on one side of a street at a time so as to allow use of the opposing sidewalk by pedestrians during construction. Where approved by the Engineer, the Contractor shall block a pedestrian corridor and post signs at each corner of a block where sidewalk work is being done with the following wording in 3 inch black letters on an orange background: "SIDEWALK CLOSED TO THROUGH TRAFFIC, USE OTHER SIDE".

All driveways shall be opened between 5:00 p.m. and 7:00 a.m. on weekdays and at all times on weekends and public holidays, except those that are freshly poured. All driveways which are freshly poured may be closed for one (1) calendar day and may require plating with cutback at plate edges or other means to comply with this requirement. Before restricting access to driveways, the Contractor shall notify the affected residents and/or businesses, in writing, at least seventy-two (72) hours in advance.

If during the course of the work, the City agrees that it is necessary to restrict access to certain driveways for an extended period of time, the Contractor shall notify the affected residents and/or businesses, in writing, at least 10 working days in advance.

Where a business property has more than two vehicular paths of access, one path, 10 feet in width, shall remain open during all business hours, unless accepted by the Engineer.

MEASUREMENT AND PAYMENT

The contract lump sum price paid for "Traffic Management" (Bid Item 2) shall include full compensation for furnishing all labor (including preparation of the Construction Phasing Plan, Traffic Control Plans, Temporary Traffic Controls, and flaggers when necessary), materials (including barricades, changeable message signs, banners, door hangers and temporary traffic delineation), tools, equipment, and incidentals and for doing all the work complete in place for each phase of construction, including all work necessary to provide for the convenience & safety of the public and to facilitate the performance of the contract work as shown on the Plans, as specified in the Standard Specifications and these Specifications, and as directed by the Engineer.

The Contractor shall be paid on pro rata basis for the work done per month, and said payment shall be for providing all labor, material, equipment, devices, supervision, and all incidentals as are needed to provide traffic control as specified herein, and as may be required to complete the work.

11. CONSTRUCTION AREA SIGNS

General:

Construction area signs shall be furnished, installed, maintained, and removed when no longer required in conformance with the provisions in the latest edition of the California Manual on Uniform Traffic Control Devices (California MUTCD), these Specifications, and as directed by the Engineer.

Submittals:

Contractor shall submit Construction Information Sign format and content to City for review. Construction Information Sign shall include the following:

1. Name of project
2. Name of 24/7 contact name and number for contractor
3. City contact name and number
4. Starting and completion dates of the contract.

Execution:

The Contractor shall notify the appropriate regional notification center for operators of subsurface installations at least 2 working days, but not more than 14 calendar days, prior to commencing excavation for construction area sign posts.

The Construction Information Sign will be erected 7 days in advance of any work.

Excavations required to install construction area signs shall be performed by hand methods without the use of power equipment, except that power equipment may be used if it is determined there are no utility facilities in the area of the proposed post holes.

Sign substrates for stationary mounted construction area signs may be fabricated from fiberglass reinforced plastic as specified under "Prequalified and Tested Signing and Delineation Materials" of these Specifications.

The Contractor may be required to cover certain signs during the progress of the work.

Signs that are no longer required or that convey inaccurate information to the public shall be immediately covered or removed, or the information shall be corrected. Covers for construction area signs shall be of sufficient size and density to completely block out the complete face of the signs. The retroreflective face of the covered signs shall not be visible either during the day or at night. Covers shall be fastened securely so that the signs remain covered during inclement weather. Covers shall be replaced when they no longer cover the signs properly.

Minor deviations from the requirements of this section concerning hours of work which do not significantly change the cost of the work may be permitted upon the written request of the Contractor if in the opinion of the City Engineer public traffic will be better served and the work expedited. Such deviations shall not be adopted until the City Engineer has indicated his written approval. All other modifications shall be made by contract change order.

If any component in the traffic control system is displaced, or ceases to operate or function as specified, from any cause, during the progress of the work, the Contractor shall immediately repair said component to its original condition or replace said component and shall restore the component to its original location.

MEASUREMENT AND PAYMENT

The contract lump sum price paid for "Construction Area Signs" (Bid Item 3) shall include full compensation for furnishing all labor, materials, tools, equipment, and incidentals and for doing all the work involved in construction area signs, complete in place, including placing, maintaining, removing and disposing of construction area signs, or any other equipment used to protect the public or designate construction areas, as shown on the Plans, as specified in the Standard Specifications and these Specifications, and as directed by the Engineer.

12. ROADWAY SIGNS

General:

Roadside signs shall be furnished and installed on new foundations at the locations shown on the Plans or where designated by the Engineer and in conformance with the provisions in the Standard Plans and Specifications and these special provisions.

Submittals:

Contractor shall provide submittal for each Respective manufacturer's product data for manufactured products.

Materials:

- Signs shall be installed per Section 56 of the Standard Specifications and these Specifications.
- Roadside sign posts shall be one of the following or approved equal:
 1. Western Highway Products
10680 Fern Ave.
Stanton, CA 90680
(800)479-3793
Model: Ulti-Mate Sign Support System
 2. Zumar Industries, Inc.
9719 Santa Fe Springs Road
Santa Fe Springs, CA 90670
(800)654-7446 www.zumar.com
Model: Perforated Square Steel Sign Posts
 3. Tapco
5100 W. Brown Deer Road
Brown Deer, WI 53223
(800)236-0112 www.tapco.com
Model: Galvanized Square Post
- Posts for roadside signs shall conform to State Standard Plan RS1. Posts shall have a bolt installed at the base of the post, as recommended by the manufacturer, and as directed by the Engineer. Posts shall be 12-gage galvanized steel 1.75-inch square tube with perforations, weighing 2.09 pounds per linear foot.

Execution:

1. Existing roadside signs shall be removed and salvaged as shown on the Plans. Foundations and posts shall be removed and legally disposed of outside of the Right-of-Way. Metal sign posts to be removed in sidewalk areas shall be removed by cutting and grinding the posts flush with the grade of the sidewalk. Any holes or depressions shall be leveled with grout; vertical ledges or protrusions greater than ¼" shall not be allowed.
2. Existing roadside signs shall not be removed until replacement signs have been installed or until the existing signs are no longer required for the direction of public traffic, unless otherwise directed by the Engineer.
3. Roadside signs and mounting shall be installed at the locations shown on the Plans, or where directed by the Engineer and shall conform to the provisions in Section 56-4, "Roadside Signs," of the State Standard Specifications and these Special Provisions. Existing and new signs to be mounted to existing or new posts shall be done in accordance with applicable Caltrans standards.

MEASUREMENT AND PAYMENT

The contract unit price paid to "Roadside Sign" (Bid Item 4) shall be paid per each and shall include full compensation for furnishing the sign and sign post, all labor, materials, tools, equipment, incidentals, installation of posts and foundations, and for doing all the work involved in installing roadway signs as shown in the Plans.

Installation of roadside signs on signal poles shall be included in the lump sum cost of the traffic signal work.

13. UTILITY ADJUSTMENTS TO GRADE

General:

Valve boxes, maintenance holes, and other similar facilities shall be relocated and/or adjusted to grade after sidewalk and/or pavement improvements, where applicable, in accordance with the applicable provisions of Section 15-1.03 of the Standard Specifications.

Contractor shall adhere to applicable utility agency requirements for raising utility. Adjustment of PG&E facilities shall be per Greenbook requirements.

Submittals:

The Contractor shall submit material cut sheets and suppliers' certificates for the following materials, including but not necessarily limited to: grade rings, Portland Cement concrete, and mortar.

Execution:

Use of metal riser rings for storm drain maintenance holes is not acceptable. Grade rings, if used, shall be placed before resurfacing. The height of the grade ring shall be equal to the thickness of the overlay pavement to be placed, or shall be of such height so as to adjust the maintenance hole to grade.

Where frames and covers cannot be lowered flush after cold planing or before replacing asphalt surfacing, frames and covers shall be protected utilizing the following alternatives:

- Ramp section (cut-back) around "iron" and paint white
- Place lighted Portable Barricade over iron

Existing water valve access covers and fire hydrants shall be adjusted to grade in accordance with the East Bay Municipal Water District (EBMUD) Standards and these Specifications.

Where frames and covers cannot be lowered flush after cold planing or before replacing asphalt surfacing, frames and covers shall be protected utilizing the following alternatives:

- Ramp section (cut-back) around "iron" and paint white
- Place lighted Portable Barricade over iron

All utility covers encountered in the area to be overlaid with Hot Mix Asphalt shall be carefully referenced out using spray chalk or similar non-permanent marking media prior to the overlay by the Contractor. Using the reference markings, the locations of the covers

shall be painted on the pavement surface immediately after paving to assure they can be found in an emergency.

Covers shall be adjusted so that there will not be any perceptible difference in elevation between the finished pavement surface and the cover. The Engineer shall be the sole judge of the acceptable degree of smoothness of passage of a motor vehicle over the adjusted covers.

Portland cement concrete used for adjusting covers shall be minor concrete conforming to the requirements of Section 90-2 "Minor Concrete" of the Standard Specifications with at least 505 pounds of cementations material per cubic yard and 1-inch maximum graded coarse aggregate. No bagged mix is permitted.

Mortar used in resetting maintenance hole covers shall conform to the provisions in Section 51-1.02F, "Mortar" of the State Standard Specifications.

Salvaged materials which are undamaged may be reinstalled as directed by the Engineer.

Structures built of cast-in-place or precast concrete and brick or vitrified clay pipe parts shall be replaced in kind, unless otherwise permitted by the owners of the facilities.

Each of the respective utility company shall retain the ability to decrease the amount of a contract item of work or eliminate in its entirety. No adjustment to the number of working days will be made.

Contractor shall provide at least 48 hours advance notice to each respective utility agency of iron castings to be adjusted to grade.

MEASUREMENT AND PAYMENT

"Adjust AT&T MH Frame & Cover to Grade" and "Adjust WCWD HM Frame & Cover to Grade" and "Adjust EBMUD Valve Cover to Grade" and "Adjust PG&E Gas Valve Cover to Grade" and "Adjust WCWD Rodding Cover to Grade" and measurement and payment items are revocable items. Bid items noted as "revocable items" may be deleted entirely or in part from the Work at the option of the City. The provisions of Section 9-1.06B, "Increases of More Than 25 Percent", and Section 9-1.06C, "Decreases of More Than 25 Percent", of the Standard Specifications shall not apply to such omission, and no compensation will be allowed the Contractor by reason of such omission.

The price paid for each "Adjust AT&T MH Frame & Cover to Grade (Revocable Item)" (Bid Item 5) shall include full compensation for furnishing all labor, materials, coordination with utility agency, and equipment necessary to complete the work as shown on the Plans and specified herein and as directed by the Engineer and no additional payment will be allowed therefore.

The price paid for each "Adjust WCWD HM Frame & Cover to Grade (Revocable Item)" (Bid Item 6) shall include full compensation for furnishing all labor, materials, coordination with Utility agency, and equipment necessary to complete the work as shown on the Plans and specified herein and as directed by the Engineer and no additional payment will be allowed therefore.

The price paid for each "City HM Frame & Cover to Grade" (Bid Item 7) shall include full compensation for furnishing all labor, materials, coordination with Utility agency, and equipment necessary to complete the work as shown on the Plans and specified herein and as directed by the Engineer and no additional payment will be allowed therefore.

The price paid for each "Adjust EBMUD Valve Cover to Grade (Revocable Item)" (Bid Item 8) shall include full compensation for furnishing all labor, materials, coordination with Utility agency, and equipment necessary to complete the work as shown on the Plans and specified herein and as directed by the Engineer and no additional payment will be allowed therefore.

The price paid for each "Adjust PG&E Gas Valve Cover to Grade (Revocable Item)" (Bid Item 9) shall include full compensation for furnishing all labor, materials, coordination with Utility agency, and equipment necessary to complete the work as shown on the Plans and specified herein and as directed by the Engineer and no additional payment will be allowed therefore.

The price paid for each "Adjust WCWD Rodding Cover to Grade (Revocable Item)" (Bid Item 10) shall include full compensation for furnishing all labor, materials, coordination with Utility agency, and equipment necessary to complete the work as shown on the Plans and specified herein and as directed by the Engineer and no additional payment will be allowed therefore.

The price paid for each "Adjust Utility Box Frame & Cover to Grade (Revocable Item)" (Bid Item 11) shall include full compensation for furnishing all labor, materials, coordination with Utility agency, and equipment necessary to complete the work as shown on the Plans and specified herein and as directed by the Engineer and no additional payment will be allowed therefore.

The price paid for each "City Monument Frame & Cover to Grade (Revocable Item)" (Bid Item 12) shall include full compensation for furnishing all labor, materials, coordination with Utility agency, and equipment necessary to complete the work as shown on the Plans and specified herein and as directed by the Engineer and no additional payment will be allowed therefore.

14. CITY MONUMENT PRESERVATION

General:

The Contractor shall be responsible for protecting in place and replacing disturbed markers and monuments per the State Standard Plan A74.

Execution:

Replacement of Reference Survey Monument and Marker - The Contractor shall replace removed and/or disturbed markers and monuments resulting from construction work per the State Standard Plan A74. Re-establish survey markers and monuments in conformance with the recorded reference points. The Contractor shall forward to the Engineer a letter verifying re-establishment of survey markers and monuments, signed by a licensed land surveyor currently registered in the State of California. Prior to removing or construction work which may disturb a marker and/or monument, the contractor shall record the locations and designation of survey markers and monuments. The Contractor shall provide three (3)

reference points for each survey marker and monument removed, established by a licensed land surveyor currently registered in the State of California. Monument referencing shall be done by a licensed land surveyor hired by the contractor, and copies of the corner records for the referenced monuments shall be provided to the City prior to the start of construction.

For each monument that has been removed, the replacement monument location(s) will be established by the referencing surveyor after final pavement is completed.

In the event that any non-referenced monuments or monument reference points become in danger of being disturbed due to construction, the Contractor shall cease the threatening activity and notify the Project Manager and City Survey Staff immediately. In no case may an unreferenced monument or monument reference point be damaged during construction.

Should any monument not designated for replacement be disturbed or sustain damage during construction, the Contractor shall bear the expense for rebuilding it as well as for the survey work the City survey crew or its survey consultant must perform in the process. In any instance where the City deems a damaged monument to be irreplaceable, whether designated or not designated for replacement, the Contractor shall be fined \$20,000 per monument.

MEASUREMENT AND PAYMENT

Full compensation for "Monument Preservation" shall include full compensation for furnishing all labor, materials, tools, equipment, supervision, and incidentals and for doing all the work involved as specified in the Standard Specifications and Plan, these Specifications, and as directed by the Engineer as may be required to complete the work and shall be considered as included in the contract prices for the various items of work and no additional compensation will be made therefor.

15. BASE FAILURE REPAIR

General:

Specifications are for providing asphaltic concrete paving dig-outs as directed by the Engineer. Contractor shall protect asphalt and/or concrete pavements and walks, curbs and bases, and other improvements adjacent to the operations with suitable materials. The Contractor shall be responsible for any damage caused by the Contractor's employees or equipment and shall make necessary repairs. All damage caused by the Contractor's operations shall be prepared or replaced as required.

Submittals:

Contractor shall provide submittal for each Respective manufacturer's product data for manufactured products.

Materials:

- Hot Mix Asphalt shall be Type A using the Method process and shall conform to the provision in Section 39 "Hot Mix Asphalt" of the Standard Specifications and these Specifications. Hot Mix Asphalt shall be compacted to a relative compaction of not less than 95 percent per ASTM D-1557.

Aggregate grading for the hot mix asphalt shall conform to the grading specified in Section 39-2.02B "Aggregate Gradations" of the Standard Specifications. The base and leveling courses shall be dense graded, 3/4-inch maximum aggregate size and the surface course shall be medium graded 1/2-inch maximum aggregate size. When material used in the surface course is to be hand raked, 3/8-inch maximum size shall be used.

The amount of asphalt binder to be mixed with the aggregate shall be between 4 percent and 6 percent by weight of the dry aggregate. The exact amount of asphalt binder to be mixed with the aggregate will be approved by the Engineer. The Contractor must submit mix design for approval to the Engineer.

Asphalt binder to be mixed with aggregate shall be a steam-refined asphalt conforming to the provisions in Section 92, "Asphalt Binders" and have a viscosity grade of PG 64-10. The pavement surface upon which hot mix asphalt is to be placed and all adjacent vertical surfaces of existing pavement, curbs, gutters, etc. shall be thoroughly cleaned prior to paving. The Contractor shall furnish and operate a self-loading motor sweeper with spray nozzles before and after paving operations where feasible. All other areas will require hand sweeping. The pavement shall be free of dust, dirt, water, and vegetation prior to paving.

Asphaltic emulsion shall be applied to the surface of existing pavements preparatory to resurfacing with hot mix asphalt, and to all concrete surfaces which will be in contact with hot mix asphalt surfacing. Asphalt emulsion shall be SS-1H. The Contractor shall submit a copy of Certificate of Compliance for asphaltic emulsion

Execution

As indicated in the field by the Engineer in white paint, the Contractor shall coordinate quantities for standard and deep dig-out repairs. Contractor shall sawcut all limits of dig-outs and field determine with the Engineer the appropriate depth of dig-out. Contractor shall assume 4" minimum to 11" maximum grind depths for deep dig-outs.

MEASUREMENT AND PAYMENT

The contract price paid per square foot for "Base Failure Repair" (Bid Items 13.1 and 13.2) shall include full compensation for furnishing all labor, materials, tools, equipment, and incidentals, and for doing all the work involved in furnishing and placing hot mix asphalt, applying paint binder, and performing in-place density and compaction tests, complete in place as shown on the Plans, as specified in the Standard Specifications and these Specifications, and as directed by the Engineer

16. HOT MIX ASPHALT (TYPE A)

Specifications are for providing asphaltic concrete paving as indicated on drawings. Contractor shall protect concrete pavements and walks, curbs and bases, and other improvements adjacent to the operations with suitable materials. The Contractor shall be responsible for any damage caused by the Contractor's employees or equipment and shall make necessary repairs. All damage caused by the Contractor's operations shall be prepared or replaced as required.

Submittals:

Contractor shall submit Certificate of Compliance from manufacturer for approval prior to installation.

Contractor shall provide submittal for each Respective manufacturer's product data for manufactured products.

Materials:

- Hot Mix Asphalt shall be Type A using the Method process and shall conform to the provision in Section 39 "Hot Mix Asphalt" of the Standard Specifications and these Specifications. Hot Mix Asphalt shall be compacted to a relative compaction of not less than 95 percent.

Aggregate grading for the hot mix asphalt shall conform to the grading specified in Section 39-2.02B "Aggregate Gradations" of the Standard Specifications. The base and leveling courses shall be dense graded, 3/4-inch maximum aggregate size and the surface course shall be medium graded 1/2-inch maximum aggregate size. When material used in the surface course is to be hand raked, 3/8-inch maximum size shall be used.

The amount of asphalt binder to be mixed with the aggregate shall be between 4 percent and 6 percent by weight of the dry aggregate. The exact amount of asphalt binder to be mixed with the aggregate will be approved by the Engineer. The Contractor must submit mix design for approval to the Engineer.

Asphalt binder to be mixed with aggregate shall be a steam-refined asphalt conforming to the provisions in Section 92, "Asphalt Binders" and have a viscosity grade of PG 64-10. The pavement surface upon which hot mix asphalt is to be placed and all adjacent vertical surfaces of existing pavement, curbs, gutters, etc. shall be thoroughly cleaned prior to paving. The Contractor shall furnish and operate a self-loading motor sweeper with spray nozzles before and after paving operations where feasible. All other areas will require hand sweeping. The pavement shall be free of dust, dirt, water, and vegetation prior to paving.

- Asphaltic emulsion shall be applied to the surface of existing pavements preparatory to resurfacing with hot mix asphalt, and to all concrete surfaces which will be in contact with hot mix asphalt surfacing. Asphalt emulsion shall be SS-1H. The Contractor shall submit a copy of Certificate of Compliance for asphaltic emulsion
- GlasPave50 Paving Mat by Tensar or Engineer approved equivalent

Execution:

1. Placing of Base Course

- a. The Contractor shall call for an inspection by the Engineer and obtain written approval of the subgrade before proceeding with the base course.
- b. Base course shall be minimum uniform thickness after compaction of dimensions indicated. Where not indicated, compacted thickness shall be

six inches for parking stalls and eight inches for roads, driveways, and aisles of parking areas.

- c. Base course shall be placed over finished subgrade and compacted in accordance with Section 26-1.03E Compacting of the State Standard Specifications.
- d. After base course has been completed, the Contractor shall call for an inspection by the Engineer and obtain written approval before proceeding with application of the asphalt wearing surface.

2. Placing Asphalt Concrete

- a. The asphalt paving machine shall be equipped with an electronic "sonic ski" system with a minimum of three (3) sensors to be positioned a minimum of 10-foot in front, 10-foot behind and adjacent to the drum of the paving machine. The system shall be designed to optimize a smooth and consistent road profile. All settings and inputs shall be programmed and adjusted to yield an average thickness equivalent to the paving thickness shown on the Plans. The engineer can cancel the use of the "sonic ski" system at any point without incurring any penalties by the contractor.
- b. Areas to be paved shall be covered with a layer of hot asphalt concrete surfacing not less than the thickness indicated after compaction. Where not indicated, compacted thickness shall three inches for roads, driveways, and aisles of parking areas.
- c. Paving asphaltic concrete shall be delivered, laid, rolled, and finished in accordance with Section 39 of the Caltrans Standard Specifications.
- d. Before placing asphalt concrete, a tack coat (paint binder) shall be applied to all vertical surfaces against which asphalt concrete surfacing will be placed. Asphaltic emulsion shall be applied to the surface of existing pavements at the approximate rate of one-sixteenth (1/16) gallon per square yard. Pools or unevenly distributed areas shall be redistributed by means of hand brooms. The emulsion shall be applied only so far in advance of the surfacing work that it has sufficient time to set, as required by the Engineer.
- e. After a tack coat of asphalt emulsion has been applied, hot mix asphalt shall be spread and compacted. It is contemplated that hot mix asphalt will be laid to a compacted thickness as specified. All loose material tracked out onto the new compacted surface shall be removed before an adjacent pass is made by the asphalt paver. All layers of hot mix asphalt shall be laid using an asphalt paving machine as specified in Section 39, Hot Mix Asphalt, of the Standard Specifications.
- f. The Contractor shall taper the new pavement thickness adjacent to the gutters in the streets designated by the Engineer. Tapering to the edge of the gutters shall be performed in such manner that adequate binding of the very fine asphalt material to the existing surface is obtained. Contractor shall, at the direction of the Engineer and pursuant to field conditions, apply additional binding material in these areas prior to the placement of the new

hot mix asphalt, and shall adequately rake the coarse material so as to obtain the desired result. Crown heights may be adjusted at the direction of the Engineer. Aggregate segregation will be grounds for rejection.

- g. The location of all utility and City-owned structures that are covered over by the new pavement shall be legibly marked with paint on the new pavement and on the adjacent curb and/or sidewalk. In addition, the Contractor must make a list of each utility cover that is paved over and not raised to grade during the paving job (e.g. PG&E utility covers) and must notify the utility in writing of the location of said utility cover and the date that it was paved over. A copy of this written notification must be sent to the City. If utility cover is paved over and not raised to grade during the paving job, the pavement must be at least 1-1/2 inches thick over the utility cover and no depression in the roadway surface can be left over the utility cover. If 1-1/2 inches of pavement cannot be laid over a recessed utility cover, then the hot mix asphalt shall be feathered to the grade of the utility cover and arrangements with the utility must be made to raise it to grade. Hot mix asphalt rolled gutters shall be resurfaced as directed by the Engineer as part of the overlay resurfacing work and no additional payment will be made therefor.
- h. Hot mix asphalt shall not be placed when the atmospheric temperature is below 50 degrees F (10 degrees C) or during unsuitable weather.
- i. Compaction of the asphalt shall be achieved using mechanical rollers. Rolling shall be performed in such a manner that cracking, shoving, or displacement will be avoided. Any displacement occurring as a result of reversing the direction of the roller or from any cause shall at once be corrected by the use of rakes and fresh asphalt mixture where required.
- j. Areas inaccessible to the rollers shall be compacted by use of a power compactor of the high impact vibration plate type capable of attaining the same compaction as the rolled areas. An adequate number of rollers shall be used with each paving operation.
- k. The completed surface shall be thoroughly compacted, smooth, and true to grade and cross section, free from ruts, humps, depression, irregularities, or segregated material.
- l. Finish paving shall conform to finish elevations within plus or minus 0.01 of a foot and shall be level to within plus or minus 1/4 inch in 10 feet when measured with a 10 foot straightedge in any direction. Finish surface of the wearing course shall be thoroughly compacted, smooth, and free from ruts, humps, depressions, cold joints, or other irregularities.
- m. Public traffic shall be permitted the use of the street area providing that such traffic does not interfere with the continuity of the paving operations. When street operations are suspended, all equipment shall be removed from portions of the streets that are to be used by the public traffic. Where work is unfinished at a pedestrian crosswalk at the end of a working day, the edge of the paved surface to said crosswalk shall be feathered to provide a smooth pathway for foot traffic. The pavement shall be protected from traffic until thoroughly cooled and set. Hot mix asphalt rolled gutters shall be compacted

as directed by the Engineer as part of the overlay resurfacing work and no additional payment will be made therefor.

- n. Any rollers shall be equipped with pads and water systems that prevent sticking of asphalt mixtures to the steel-tired wheels. A parting agent, which will not damage the asphalt mixture, as determined by the Engineer, may be used to aid in preventing the sticking of the mixture to the wheels.
- o. The finished surface shall be cat-tracked within 24 hours of completion of paving work. Final striping shall be applied within one week of completion of paving work.
- p. Pavement fabric shall be installed per Manufacturer's recommendation.

3. Field Quality Control

- a. The Contractor shall control the quality of the work and shall provide adequate testing to assure compliance with these Specifications.
- b. After completion of paving work, all paving shall be inspected. Any resulting "ponds" shall be ringed with chalk. Such hollows shall be corrected with addition of asphalt paving materials and rerolling until all paving is completely level and free from hollows and high spots.
- c. As part of its quality control program, Contractor shall employ a competent qualified testing subcontractor to perform in-place density and compaction tests of the completed pavement in accordance with California Test 375 to determine compliance with specified requirements. A minimum of: three (3) tests shall be performed at each conform paving location (i.e., paving around new sidewalk/curb ramp), six (6) tests on the overlay at the fire lane (between San Rafael Way and University Avenue), and/or as directed by the Engineer to verify compliance. Contractor shall provide all test results to the Engineer by the end of the next business day.

MEASUREMENT AND PAYMENT

The work of Hot Mix Asphalt (Type A) will be measured by the tons of asphalt installed. The Contractor will not be paid for asphalt thickness above that which is specified. Contractor shall submit asphalt tags upon arrival of the delivery truck, or as directed by the Engineer.

The contract price paid per ton for "Hot Mix Asphalt (Type A)", (Bid Item 15) shall include full compensation for furnishing all labor, materials, tools, equipment, pavement fabric, and incidentals, and for doing all the work involved in furnishing and placing hot mix asphalt, applying paint binder, and performing in-place density and compaction tests, complete in place as shown on the Plans, as specified in the Standard Specifications and these Specifications, and as directed by the Engineer.

17. PAVEMENT STRIPING AND MARKINGS

General:

Specifications for providing traffic striping and control markings on pavement as indicated.

Submittals:

Contractor shall submit shop drawings and diagrams, indicating stripe width of roadway divider stripes, style and size of letters for pavement marking designation, configuration and dimensions of arrows and any other traffic control markings on pavement.

Contractor shall submit evidence or affidavit which certifies that paint to be used complies with latest CARB/VOC regulations.

A certificate of compliance shall be provided by the Contractor to the City that all materials used for pavement marking and legends conform to the Specifications.

Materials:

- Traffic stripes and pavement markings shall be installed per Section 84 of the Standard Specifications and these Specifications.
- All striping and pavement markings shall be Thermoplastic and conform to either State Specifications 8020-41G-19 or 8010-41G-21. State Specifications for thermoplastic material and glass beads may be obtained from the Transportation Laboratory, P.O. Box 19128, Sacramento, California, 95819- (916) 739-2400. Thermoplastic material for all pavement markings shall be applied at a minimum thickness of 0.070-inch.

Execution:

1. All existing pavement markers and thermoplastic stripes and legends within the roadway reconstruction shall be completely removed immediately prior to hot mix asphalt paving. Markers, stripes, or legends which are removed shall be replaced with temporary markers, stripes and legends prior to opening the roadway to vehicular or pedestrian traffic.
2. All traffic striping, pavement markings (legend), and pavement markers removed prior to excavation or grinding shall be replaced except as modified in the Plans or as directed by the Engineer. Prior to replacement, the Contractor shall layout all striping patterns and marking locations by cat tracking or other suitable means for review and approval by the Engineer. Any striping and/or markings installed by the Contractor that the Engineer has not pre-approved, and that the Engineer determines are installed improperly or in the wrong location, shall be removed and replaced to the satisfaction of the Engineer at the Contractor's sole expense.
3. Surfaces which are to receive markings shall be thoroughly cleaned, free from loose materials and dry. Such areas shall be prepared by the Contractor to the satisfaction of the Engineer.
4. Any damage to existing or newly placed traffic striping due to the failure of the Contractor to protect the work, and correction of errors, shall be repaired by the Contractor at no additional cost.
5. All new traffic stripes and pavement markings shall meet the following requirements for applications with enhanced wet night visibility:

Quality Control and Assurance

1. Within 14 days of applying a thermoplastic traffic stripe or pavement marking with enhanced wet night visibility, the retroreflectivity must be a minimum of 700 millicandelas per square meter per lux for white stripes and markings and 500 millicandelas per square meter per lux for yellow stripes and markings. Test the retroreflectivity under ASTM E 1710. Have a reflectometer as described in ASTM E 1710 at the job site for making these measurements.
2. Thermoplastic traffic stripes and pavement markings with enhanced wet night visibility must consist of a single uniform layer of thermoplastic and 2 layers of glass beads as follows:
 - a. The first layer of glass beads must be on the Authorized Material List under high-performance retroreflective glass beads for use in thermoplastic traffic stripes and pavement markings. The color of the glass beads must match the color of the stripe or marking to which they are being applied.
 - b. The 2nd layer of glass beads must comply with AASHTO M 247, Type 2.
3. Both types of glass beads must be surface treated for use with thermoplastic under the bead manufacturer's instructions.

Construction

1. Use a ribbon extrusion or screed type applicator to apply a thermoplastic traffic stripe.
2. Operate the striping machine at a speed of 8 mph or slower during the application of thermoplastic traffic stripe and glass beads.
3. Apply a thermoplastic traffic stripe at a rate of at least 0.38 pounds per foot of 4-inch wide solid stripe. The applied thermoplastic traffic stripe must be at least 0.090 inch thick.
4. Apply a thermoplastic pavement marking at a rate of at least 1.06 pounds per square foot. The applied thermoplastic pavement marking must be at least 0.100 inch thick.
5. Apply a thermoplastic traffic stripe and both types of glass beads in a single pass. Apply the thermoplastic 1st, followed immediately by consecutive applications of high-performance glass beads and then AASHTO M 247, Type 2 glass beads. Use 2 separate applicator guns for the glass beads, 1 applicator gun for each type of glass bead.
6. Contractor may apply glass beads by hand methods on pavement markings.
7. Distribute all glass beads uniformly on traffic stripes and pavement markings. Apply high-performance glass beads at a rate of at least 6 pounds per 100 square feet of stripe or marking. Apply AASHTO M 247, Type 2 glass beads at a rate of at least 8 pounds per 100 square feet of stripe or marking. The combined weight of the 2 types of glass beads must be greater than 14 pounds per 100 square feet of stripe or marking.

MEASUREMENT AND PAYMENT

The contract unit price paid per linear foot for pavement striping, white and yellow, (Bid Items 16-19) shall include full compensation for furnishing all labor, materials, tools, equipment, and incidentals, and for doing all the work involved in preparing the surface (including striping and marker removal) and installation of pavement striping as shown in the Plans, as specified in the Standard Specifications and these Specifications, and as directed by the Engineer.

The contract unit price paid per square foot for "White Pavement Markings (Thermoplastic)" (Bid Item 20) shall include full compensation for furnishing all labor, materials, tools, equipment, and incidentals, and for doing all the work involved in preparing the surface (including pavement markings removal) and installation of pavement markings as shown in the Plans, as specified in the Standard Specifications and these Specifications, and as directed by the Engineer.

The contract unit price paid per each "Two-Way Reflective Pavement Marker" (Bid Item 21) shall include full compensation for furnishing all labor, materials, tools, equipment, and incidentals, and for doing all the work involved in preparing the surface (including pavement markings removal) and installation of pavement markings as shown in the Plans, as specified in the Standard Specifications and these Specifications, and as directed by the Engineer.

18. CURB PAINT

General:

Specifications for providing curb paint as indicated.

Submittals:

Contractor shall submit shop drawings and diagrams, indicating location, color, and dimensions of curb paint.

Materials:

- Curb paint shall conform to the requirements in ASTM Designation: D 6628-01.
- Retroreflectivity of the paint traffic stripes and pavement markings shall conform to the requirements in ASTM Designation: E 1710.
- Paint type shall be Waterborne Traffic Line conforming to the requirements of Federal Specification TT-P-1952E.

Painted curb markings work consists of painting curbs with (red, white, or blue) paints as shown in the Plans. All work shall be performed in conformance with the provisions in Section 84, "Traffic Stripes and Pavement Markings," of the Standard Specifications and these Specifications at the locations shown on the Plans and as directed by the Engineer.

Execution:

1. Application shall consist of two separate coats of traffic paint of the appropriate color to the face and top of the curb.
2. Nothing in these Specifications shall relieve the Contractor from their responsibilities as provided in Section 7-1.09, "Public Safety," of the Standard Specifications.

MEASUREMENT AND PAYMENT

The contract unit price paid per linear foot for "Curb Paint" (Bid Item 22) shall include full compensation for furnishing all labor, materials, tools, equipment, and incidentals, and for doing all the work involved in painting red curbs as shown in the Plans, as specified in the Standard Specifications and these Specifications, and as directed by the Engineer.

19. CONCRETE CURB RAMP

General:

Concrete curb ramps shall conform to the State Standard Curb Ramp Details Plan A88A and as modified in the Plans and as directed by the Engineer. All Work shall be done including subgrade compaction shall meet the acceptance of the Engineer.

The contractor shall provide temporary asphalt concrete paving transitions, as approved by the Engineer, for necessary construction phasing.

Damage to the street, sidewalk, curbs and gutters from construction activities shall be repaired to the satisfaction of the City Engineer.

Submittals:

The General Contractor shall submit the concrete mix design and strength data to the Engineer for favorable review the following.

Supplier's certificates showing conformance with this specification shall be delivered to the Engineer with each shipment of materials delivered to the job site.

Materials:

- Portland Cement Concrete for fixed form concrete surface improvements shall be minor concrete conforming to the requirements of Section 90-2 "Minor Concrete" of the Standard Specifications with at least 505 pounds of cementitious material per cubic yard and 1-inch maximum graded coarse aggregate. No bagged mix is permitted. Hand mixing of Portland Cement Concrete for use in concrete surface improvements shall not be permitted. For concrete paving subjected to vehicular traffic, strength of concrete in place shall be 4,000 psi at 28 days. No admixtures shall be used without approval of the Engineer.

Maximum slump of fresh concrete permitted in these items shall be 4 inches. Slump shall be determined by either ASTM C-143 or California Test Method No. 520 at the Engineer's discretion.

- Aggregate base shall be Class 2, 3/4" maximum. When the aggregate base is constructed in more than one layer, the previously constructed layer shall be cleaned of loose and foreign matter by sweeping with power sweepers or power brooms, except that hand brooms may be used in areas where power cleaning is not practicable. Adequate drainage shall be provided during the entire period of construction to prevent water from collecting or standing on the area to be covered with aggregate base.
- Truncated Domes shall be approved by the Engineer and meet requirements listed in the Part 2 of Title 24 of the California Code of Regulations Chapter 11B-705

Execution:

Formwork

- Prior to forming for concrete surface improvements, the Contractor shall pass the compaction test for the subgrade from the Geotechnical Engineer.
- Forms for concrete surface improvements shall be subject to the approval of the Engineer. No concrete shall be placed prior to Contractor obtaining such approval.
- Forms for concrete surface improvements shall have a smooth and true upper edge and the side of the form to be placed next to concrete shall have a smooth finish. Forms shall be constructed rigid enough to withstand the pressure of the fresh concrete to be placed without any distortion.
- All forms shall have been thoroughly cleaned prior to placement and shall be coated with an approved form oil sufficient to prevent adherence of concrete prior to filling.
- Forms shall be carefully set to the alignment and grade required by the Plans. Forms shall be rigidly held in place by stakes set at intervals satisfactory to the Engineer. Sufficient clamps, spreaders and braces shall be installed to ensure the rigidity of the forms.
- Forms for edge of walks, driveways or other surface slabs shall be equal to the full depth of the concrete as shown, noted or called for on the Plans or detail drawings. Composite forms made up from benders or thin planks of sufficient ply to ensure rigidity of the form in the shape required may be used on curves and curb returns.
- Sidewalks, driveways and PCC pads shall have forms removed and be backfilled within 3 days after pouring.

Concrete Placement

- Where a portion of existing concrete surface improvements is to be reconstructed, the section to be removed shall first be separated from that to remain by means of a cut with an approved concrete saw to a minimum depth of one and one-half (1-1/2) inches at the first score line beyond the area to be replaced.

- b. All repairs to concrete surface improvements shall be made by completely removing and replacing the entire portion between the score lines or joints.
- c. Prior to subgrade work and concrete placement, all debris and trash will be removed from all areas related to this work. Existing subgrade surface shall be re-graded (if necessary) and re-compacted to conform to the grades shown on the Plans.
- d. Any concrete discolored, defaced, or otherwise damaged before official acceptance shall be cleaned, repaired or replaced at the Contractor's expense.
- e. If existing utilities are found to interfere with the permanent facilities being constructed under this Contract, immediately notify the Engineer and secure instructions. Do not proceed with permanent relocation of utilities until written instructions are received from the Civil Engineer.
- f. Contractor shall accurately grade and prepare the site to the lines and grades called for on the Plans and detail drawings with due provision for future surface improvements.
- g. Surface tolerance: Finished paving surfaces shall not vary more than 1/4 inch measured with a 10-foot metal straight edge, except at grade changes. No birdbaths or other surface irregularities will be permitted. Correct irregularities to the satisfaction of the Engineer without additional cost to the project.
- h. Concrete shall be transported in truck mixers or agitators and discharged within 70 minutes of leaving the plant.
- i. All new sidewalk, driveways, and PCC pads adjacent to existing concrete curb or sidewalk shall be dowelled to the existing concrete. The dowels shall be #4 rebar, 18 inches long at 18 inches maximum spacing. Dowels shall be embedded a minimum of 6-inches in a 5/8-inch drilled hole (existing concrete).
- j. Sidewalks, driveways, and PCC pad shall be given a median broom finish. The surface shall first be given a floated finish and final troweling shall be done with a steel trowel. The finished surface shall be free of all trowel marks and shall be uniform in texture and appearance. Broom texture shall be in the longitudinal direction.
- k. New concrete work shall match existing in finish, score pattern, and color, or as shown on the Plans, or as directed by the Engineer.
 - a. Rose colored concrete shall contain 6 pounds of Davis #160 (Rose) per cubic yard
 - b. All other concrete shall contain 1.5 pound of lampblack per cubic yard.

Joints

- a. Expansion joints incorporating premolded joint fillers for fixed form concrete surface improvements shall be constructed at sixteen (16) foot intervals or as appropriate to match existing pattern and at the ends of curb returns. Expansion joint filler strip shall be an approved one piece premolded 1/2" thick strip conforming to the requirements of ASTM Designation D1751 or ASTM D 994. Place top of joint filler flush with

finished concrete surface if joint sealant is not indicated. Expansion joint material shall be shaped to fit the cross section of the concrete prior to being placed.

- b. Single-Component, Self-Leveling, Silicone Joint Sealant for Concrete: Joint sealant shall conform to ASTM D 5893, Type SL. Install per manufacturer's guidelines.
- c. Scoring pattern and weakened plane joints (deep joints) shall be as indicated in the Plans and approved by the Engineer.
- d. Any tree well forming required by the engineer when placing concrete sidewalk or sawcutting necessary to conform to adjacent sidewalk shall be included in this bid item.
- e. Existing asphalt concrete shall be sawcut, removed and reconstructed for a minimum of 2-feet within edges of concrete work. Hot mix asphalt shall be a minimum thickness of 8-inches and Class 2 aggregate base shall match existing thickness.

Testing

Slump tests shall be performed by the General Contractor in the presence of the Engineer at the beginning of each day's pour and at such additional times as required by the District. Slump tests shall be made in accordance with current ASTM Designation C-143 or California Test Method No. 520 at the Engineer's discretion.

The Contractor shall hire an accredited materials testing laboratory to perform Quality Control tasks, including slump tests and compressive strength (per ASTM C39/C39M) tests. The Contractor shall sample and test three (3) cylinders at each or as directed by the Engineer:

Inspection

- a. The Engineer shall inspect and approve formwork and reinforcing steel placement prior to concrete pours. The General Contractor shall provide at least 24 hours' notice that inspections are required.

Where new curb ramps elevations do not match the existing pavement surface, the Contractor shall provide temporary asphalt paving transition with a maximum 5% slope or as approved by the Engineer. The Contractor shall remove and dispose of the temporary asphalt transition for future pavement adjustments and/or overlays as indicated in the plans.

Truncated dome panels shall be installed per manufacturer specifications in new curb ramps. Truncated dome panels shall be of vitrified polymer composite construction and embedded type. Color of truncated dome panel shall be approved by the Engineer.

MEASUREMENT AND PAYMENT

The contractor price paid for each "Concrete Curb Ramps" (Bid Item 25) shall include full compensation for furnishing all labor, materials, tools, formwork, equipment, truncated domes, testing, installation, and incidentals for doing all the work involved in constructing the curb complete in place including aggregate base or subbase as required, excavations, and

subgrade preparation as shown on the Plans, as specified in the Standard Specifications and these Specifications, and as directed by the Engineer.

20. WATER POLLUTION CONTROL

General:

The Contractor shall be responsible for implementing and managing these systems during the life of the project. The SPCP shall conform to all applicable requirements in Section 13-2, "Water Pollution Control," of the State Standard Specifications these Special Provisions, Section 30, Stormwater Pollution Control.

Submittals:

The Contractor shall submit a **Water Pollution Control Program (WPCP)** to address the storm drain and various improvements to the Engineer for approval. The WPCP shall conform to the requirements of the City of San Rafael and these Specifications.

Execution:

Water pollution control work to be included in the WPCP shall include:

1. Cleaning of vehicles by removing loose soil from the exterior of the equipment using brushes or brooms before leaving the Site.
2. Sweep adjacent streets as required by Engineer.
3. Installation of temporary inlet protection.
4. Installation of temporary construction entrance.
5. Use of concrete washout containment facility.
6. Covering of stockpiles.
7. Decontamination of construction equipment before leaving the premises.
8. Covering of soil loads taken offsite to prevent soil tracking.
9. Suspension of work upon wind gust in excess of 25 mph. At the discretion of the Engineer, work can resume if the types of work being performed are not generating large amounts of dust.
10. Dewatering of excavations and disposal of water

Dewatering work shall include:

1. Keep all excavations, including drilled shaft foundations, reasonably free from water during construction.
2. Disposal of water shall not damage property or create a public nuisance.
3. Have on hand pump equipment and machinery in good working condition for emergencies and workmen available for its operation.
4. Dewatering systems shall operate continuously until foundations are poured or trenches are backfilled.
5. Groundwater shall be controlled to prevent softening of the bottom of excavations, or formation of "quick" conditions.
6. Dewatering systems shall not remove natural soils.
7. Control surface runoff to prevent entry or collection of water excavations.
8. Release of groundwater shall be controlled to prevent disturbance of the natural foundation soils or compact fill.
9. There shall be no discharge of turbid water on site.
10. Discharge or disposal of water shall be controlled to prevent erosion

The Contractor shall not perform work that may cause water pollution until the WPCP has been approved by the Engineer. The Engineer's review and approval shall not waive any contract requirements and shall not relieve the Contractor from complying with Federal, State and local laws, regulations, and requirements.

MEASUREMENT AND PAYMENT

Full compensation for "Water Pollution Control" (Bid Item 26) shall include full compensation for furnishing all labor, materials, tools, equipment, dewatering, and incidentals and for doing all the work involved in preparing, obtaining approval of, and amending the WPCP and inspecting water pollution control practices as specified in the Standard Specifications and these Specifications, and as directed by the Engineer and shall be considered as included in the contract prices for the various items of work and no additional compensation will be made therefor.

Full compensation for implementation and maintenance of the water pollution control program shall be considered as included in the contract lump sum price paid for Water Pollution Control and no additional compensation will be allowed therefor.

21. CONSTRUCTION STAKING

General:

This section specifies the work for construction staking which consists of providing all labor, tools, equipment, materials and incidentals necessary to locate by staking all improvements, to the line and grade shown on the Plans.

Execution:

Contractor shall furnish all land surveys, establish all base lines and bench marks and make sufficient detailed surveys needed for working points, lines and elevations. The Contractor shall develop all slope stakes and batter boards. Contractor shall also develop all additional working points, lines and elevations as he or she may desire to facilitate his or her methods and sequence of construction.

All work shall be staked in order to meet the lines and grades shown on the Plans. Copies of all survey cut sheets shall be provided to the City Engineer two (2) working days before the planned work begins.

Finished grade elevations, pipe flowlines, and walls shall be within minus five hundredths (-0.05) foot of elevation and plan location.

Prior to concrete pouring, formwork and survey staking shall be reviewed and approved by the City Engineer.

MEASUREMENT AND PAYMENT

Full compensation for "Construction Layout" shall include furnishing all labor, materials, tools, equipment, supervision, and incidentals and for doing all the work involved as specified in the Standard Specifications and these Specifications, and as directed by the Engineer as may be required to complete the work and shall be considered included in the various bid items of work and no additional compensation shall be allowed therefore.

22. WOODEN RETAINING WALL

General:

Specifications are for providing Soldier Pile Wall as indicated in the design plans.

Submittals:

Contractor shall provide submittal for each Respective manufacturer's product data for manufactured products.

Materials:

- #1 Pressure Treated Timber and Lumber. All timber and lumber shall be graded in accordance with ASTM D245. All timber and lumber shall be pressure treated with wood preservative in accordance with these specifications for the service conditions to which the treated timber and lumber will be exposed. Pressure treatments shall conform to the AWPA standards.
 - Timber and lumber shall be coated on all sides with two coats of Amerloc 2 VOC or approved equal. While the second coat of Amerloc 2 is still wet, all timber or lumber member faces that will function as a walking surface will be broadcast with aluminum oxide non-skid material.
 - A final top coat of Precision Coatings PC3v100 series polyurethane (flat) (or approved equal) shall be applied on all surfaces to which the aluminum oxide non-skid material was applied.
 - Contractor shall submit coating color samples to client for selection and approval prior to fabrication.

- Fasteners
 - Timber and lumber shall be fastened with nails, spikes, bolts, rods, plates, washers and all other hardware shall be of the type, size and spacing to meet the conditions encountered.
 - Fasteners shall be hot dip galvanized in accordance with ASTM653 G185 (for hardware and connectors) and ASTM A153 (for fasteners and anchors).

- Portland Cement Concrete for fixed form concrete surface improvements shall be minor concrete conforming to the requirements of Section 90-2 "Minor Concrete" of the Standard Specifications with at least 505 pounds of cementitious material per cubic yard and 1-inch maximum graded coarse aggregate. No bagged mix is permitted. Hand mixing of Portland Cement Concrete for use in concrete surface improvements shall not be permitted. For concrete paving subjected to vehicular traffic, strength of concrete in place shall be 4,000 psi at 28 days. No admixtures shall be used without approval of the Engineer.

Maximum slump of fresh concrete permitted in these items shall be 4 inches. Slump shall be determined by either ASTM C-143 or California Test Method No. 520 at the Engineer's discretion.

- ¾" Clean crushed Rock

- Mirafi 140N Filter Fabric

Execution:

Treated/coated timber and lumber shall be stored on raised platforms and shall be stacked and supported to prevent warp.

Treated/coated timber and lumber having a specified moisture content shall be set on raised platforms and covered with suitable weatherproof protective coverings, such as tarpaulins or heavy polyethylene film. Covers shall be battened down to prevent the covers from blowing off.

All treated/coated timber and lumber shall be carefully handled to avoid splitting or damage to the surface and edges.

Erection: All carpentry shall be correctly laid out. All items of woodwork, hardware, and any other work in connection with carpentry shall be carefully fit and erected, accurately located, and shall be plumb, level, and properly aligned, and rigidly secured in place.

Preservative Coating: All field-cut edges and surfaces of treated/coated lumber shall be liberally coated with a concentrated solutions of preservative and coatings.

All components of the work shall be protected from detrimental weather and damage until construction operations are completed.

Work which cannot be covered with complete construction systems before the onset of weather detrimental to the work shall be completely covered and protected in such a manner as to deflect water and weather from the installation without damaging adjacent work.

Rough carpentry shall be protected from all damage and abuse until Final Acceptance by the Engineer.

MEASUREMENT AND PAYMENT

The contract price paid per linear foot of "Wooden Retaining Wall" (Bid Item 27) shall include full compensation for furnishing all labor, materials, tools, excavation, dewatering, equipment, supervision, and incidentals and for doing all the work involved as specified in the Standard Specifications and these Specifications, and as directed by the Engineer as may be required to complete the work.

23. VEHICLE LOOP DETECTORS

General:

Specifications are for removing, furnishing, and installing Vehicle Loop Detectors as indicated in the design plans.

Submittals:

Contractor shall provide submittal for each Respective manufacturer's product data for manufactured products.

Materials:

- Inductive Loop Conductors shall be per Section 86-1.02F of the State Standard Specifications
- Sealants for filling loop detector shall be per Section 86-1.03W of the State Standard Specifications
- Lead-in Cables shall be per Section 86-1.03F(2) of the State Standard Specifications

Execution:

Installation per Section 87-1.03V of the State Standard Specifications and as approved by the Engineer.

MEASUREMENT AND PAYMENT

The contract price paid per each "Remove and Replace Vehicle Loop Detector" (Bid Item 23) shall include full compensation for furnishing all labor, materials, tools, excavation, equipment, supervision, traffic control, connections to existing facilities, coordination, and incidentals and for doing all the work involved as specified in the Standard Specifications and these Specifications, and as directed by the Engineer as may be required to complete the work.

END OF SECTION

INTENTIONALLY LEFT BLANK

**REQUIRED CONTRACT PROVISIONS
FEDERAL-AID CONSTRUCTION CONTRACTS**

- I. General
- II. Nondiscrimination
- III. Non-segregated Facilities
- IV. Davis-Bacon and Related Act Provisions
- V. Contract Work Hours and Safety Standards Act Provisions
- VI. Subletting or Assigning the Contract
- VII. Safety: Accident Prevention
- VIII. False Statements Concerning Highway Projects
- IX. Implementation of Clean Air Act and Federal Water Pollution Control Act
- X. Certification Regarding Debarment, Suspension, Ineligibility and Voluntary Exclusion
- XI. Certification Regarding Use of Contract Funds for Lobbying
- XII. Use of United States-Flag Vessels:

Chapter 1 I. GENERAL

1. Form FHWA-1273 must be physically incorporated in each construction contract funded under Title 23 (excluding emergency contracts solely intended for debris removal). The contractor (or subcontractor) must insert this form in each subcontract and further require its inclusion in all lower tier subcontracts (excluding purchase orders, rental agreements and other agreements for supplies or services).

The applicable requirements of Form FHWA-1273 are incorporated by reference for work done under any purchase order, rental agreement or agreement for other services. The prime contractor shall be responsible for compliance by any subcontractor, lower-tier subcontractor or service provider.

Form FHWA-1273 must be included in all Federal-aid design-build contracts, in all subcontracts and in lower tier subcontracts (excluding subcontracts for design services, purchase orders, rental agreements and other agreements for supplies or services). The design-builder shall be responsible for compliance by any subcontractor, lower-tier subcontractor or service provider.

Contracting agencies may reference Form FHWA-1273 in bid proposal or request for proposal documents, however, the Form FHWA-1273 must be physically incorporated (not referenced) in all contracts, subcontracts and lower-tier subcontracts (excluding purchase orders, rental agreements and other agreements for supplies or services related to a construction contract).

2. Subject to the applicability criteria noted in the following sections, these contract provisions shall apply to all work performed on the contract by the contractor's own organization and with the assistance of workers under the contractor's immediate

superintendence and to all work performed on the contract by piecework, station work, or by subcontract.

3. A breach of any of the stipulations contained in these Required Contract Provisions may be sufficient grounds for withholding of progress payments, withholding of final payment, termination of the contract, suspension / debarment or any other action determined to be appropriate by the contracting agency and FHWA.

4. Selection of Labor: During the performance of this contract, the contractor shall not use convict labor for any purpose within the limits of a construction project on a Federal-aid highway unless it is labor performed by convicts who are on parole, supervised release, or probation. The term Federal-aid highway does not include roadways functionally classified as local roads or rural minor collectors.

Chapter 2 II. NONDISCRIMINATION

1. Equal Employment Opportunity: "Equal Employment Opportunity (EEO) requires that the contractor not discriminate and take affirmative action to assure equal opportunity. The specific affirmative action standards for the contractor's project activities under this contract are set forth under laws, executive orders, rules, regulations (28 CFR 35, 29 CFR 1630, 29 CFR 1625-1627, 41 CFR 60, and 49 CFR 27), and orders of the Secretary of Labor, as modified by the provisions prescribed herein, and imposed pursuant to 23 U.S.C. 140.". The provisions of the Americans with Disabilities Act of 1990 (42 U.S.C. 12101 et seq.) set forth under 28 CFR 35 and 29 CFR 1630 are incorporated by reference in this contract. In the execution of this contract, the contractor agrees to comply with the following minimum specific requirement activities of EEO:

a. The contractor will work with the contracting agency and the Federal Government to ensure that it has made every good faith effort to provide equal opportunity with respect to all of its terms and conditions of employment and in their review of activities under the contract.

b. The contractor will accept as its operating policy the following statement:

"It is the policy of this Company to assure that applicants are employed, and that employees are treated during employment, without regard to their race, religion, sex, sexual orientation, gender identity, color, national origin, age or disability. Such action shall include: employment, upgrading, demotion, or transfer; recruitment or recruitment advertising; layoff or termination; rates of pay or other forms of compensation; and selection for training, including apprenticeship, pre-apprenticeship, and/or on-the-job training."

2. EEO Officer: The contractor will designate and make known to the contracting officers an EEO Officer who will have the responsibility for and must be capable of effectively administering and promoting an active EEO program and who must be assigned adequate authority and responsibility to do so.

3. Dissemination of Policy: All members of the contractor's staff who are authorized to hire, supervise, promote, and discharge employees, or who recommend such action or are substantially involved in such action, will be made fully cognizant of and will

implement the contractor's EEO policy and contractual responsibilities to provide EEO in each grade and classification of employment. To ensure that the above agreement will be met, the following actions will be taken as a minimum:

a. Periodic meetings of supervisory and personnel office employees will be conducted before the start of work and then not less often than once every six months, at which time the contractor's EEO policy and its implementation will be reviewed and explained. The meetings will be conducted by the EEO Officer.

b. All new supervisory or personnel office employees will be given a thorough indoctrination by the EEO Officer, covering all major aspects of the contractor's EEO obligations within thirty days following their reporting for duty with the contractor.

c. All personnel who are engaged in direct recruitment for the project will be instructed by the EEO Officer in the contractor's procedures for locating and hiring minorities and women.

d. Notices and posters setting forth the contractor's EEO policy will be placed in areas readily accessible to employees, applicants for employment and potential employees.

e. The contractor's EEO policy and the procedures to implement such policy will be brought to the attention of employees by means of meetings, employee handbooks, or other appropriate means.

4. Recruitment: When advertising for employees, the contractor will include in all advertisements for employees the notation: "An Equal Opportunity Employer." All such advertisements will be placed in publications having a large circulation among minorities and women in the area from which the project work force would normally be derived.

a. The contractor will, unless precluded by a valid bargaining agreement, conduct systematic and direct recruitment through public and private employee referral sources likely to yield qualified minorities and women. To meet this requirement, the contractor will identify sources of potential minority group employees and establish with such identified sources procedures whereby minority and women applicants may be referred to the contractor for employment consideration.

b. In the event the contractor has a valid bargaining agreement providing for exclusive hiring hall referrals, the contractor is expected to observe the provisions of that agreement to the extent that the system meets the contractor's compliance with EEO contract provisions. Where implementation of such an agreement has the effect of discriminating against minorities or women, or obligates the contractor to do the same, such implementation violates Federal nondiscrimination provisions.

c. The contractor will encourage its present employees to refer minorities and women as applicants for employment. Information and procedures with regard to referring such applicants will be discussed with employees.

5. Personnel Actions: Wages, working conditions, and employee benefits shall be established and administered, and personnel actions of every type, including hiring, upgrading, promotion, transfer, demotion, layoff, and termination, shall be taken without

regard to race, color, religion, sex, sexual orientation, gender identity, national origin, age or disability. The following procedures shall be followed:

a. The contractor will conduct periodic inspections of project sites to insure that working conditions and employee facilities do not indicate discriminatory treatment of project site personnel.

b. The contractor will periodically evaluate the spread of wages paid within each classification to determine any evidence of discriminatory wage practices.

c. The contractor will periodically review selected personnel actions in depth to determine whether there is evidence of discrimination. Where evidence is found, the contractor will promptly take corrective action. If the review indicates that the discrimination may extend beyond the actions reviewed, such corrective action shall include all affected persons.

d. The contractor will promptly investigate all complaints of alleged discrimination made to the contractor in connection with its obligations under this contract, will attempt to resolve such complaints, and will take appropriate corrective action within a reasonable time. If the investigation indicates that the discrimination may affect persons other than the complainant, such corrective action shall include such other persons. Upon completion of each investigation, the contractor will inform every complainant of all of their avenues of appeal.

6. Training and Promotion:

a. The contractor will assist in locating, qualifying, and increasing the skills of minorities and women who are applicants for employment or current employees. Such efforts should be aimed at developing full journey level status employees in the type of trade or job classification involved.

b. Consistent with the contractor's work force requirements and as permissible under Federal and State regulations, the contractor shall make full use of training programs (i.e., apprenticeship) and on-the-job training programs for the geographical area of contract performance. In the event a special provision for training is provided under this contract, this subparagraph will be superseded as indicated in the special provision. The contracting agency may reserve training positions for persons who receive welfare assistance in accordance with 23 U.S.C. 140(a).

c. The contractor will advise employees and applicants for employment of available training programs and entrance requirements for each.

d. The contractor will periodically review the training and promotion potential of employees who are minorities and women and will encourage eligible employees to apply for such training and promotion.

7. Unions: If the contractor relies in whole or in part upon unions as a source of employees, the contractor will use good faith efforts to obtain the cooperation of such unions to increase opportunities for minorities and women. Actions by the contractor,

either directly or through a contractor's association acting as agent, will include the procedures set forth below:

a. The contractor will use good faith efforts to develop, in cooperation with the unions, joint training programs aimed toward qualifying more minorities and women for membership in the unions and increasing the skills of minorities and women so that they may qualify for higher paying employment.

b. The contractor will use good faith efforts to incorporate an EEO clause into each union agreement to the end that such union will be contractually bound to refer applicants without regard to their race, color, religion, sex, sexual orientation, gender identity, national origin, age, or disability.

c. The contractor is to obtain information as to the referral practices and policies of the labor union except that to the extent such information is within the exclusive possession of the labor union and such labor union refuses to furnish such information to the contractor, the contractor shall so certify to the contracting agency and shall set forth what efforts have been made to obtain such information.

d. In the event the union is unable to provide the contractor with a reasonable flow of referrals within the time limit set forth in the collective bargaining agreement, the contractor will, through independent recruitment efforts, fill the employment vacancies without regard to race, color, religion, sex, sexual orientation, gender identity, national origin, age, or disability; making full efforts to obtain qualified and/or qualifiable minorities and women. The failure of a union to provide sufficient referrals (even though it is obligated to provide exclusive referrals under the terms of a collective bargaining agreement) does not relieve the contractor from the requirements of this paragraph. In the event the union referral practice prevents the contractor from meeting the obligations pursuant to Executive Order 11246, as amended, and these special provisions, such contractor shall immediately notify the contracting agency.

8. Reasonable Accommodation for Applicants / Employees with Disabilities: The contractor must be familiar with the requirements for and comply with the Americans with Disabilities Act and all rules and regulations established thereunder. Employers must provide reasonable accommodation in all employment activities unless to do so would cause an undue hardship.

9. Selection of Subcontractors, Procurement of Materials and Leasing of Equipment: The contractor shall not discriminate on the grounds of race, color, religion, sex, sexual orientation, gender identity, national origin, age, or disability in the selection and retention of subcontractors, including procurement of materials and leases of equipment. The contractor shall take all necessary and reasonable steps to ensure nondiscrimination in the administration of this contract.

a. The contractor shall notify all potential subcontractors, suppliers, and lessors of their EEO obligations under this contract.

b. The contractor will use good faith efforts to ensure subcontractor compliance with their EEO obligations.

10. Assurances Required:

a. The requirements of 49 CFR Part 26 and the State DOT's U.S. DOT-approved DBE program are incorporated by reference.

b. The contractor, sub recipient or subcontractor shall not discriminate on the basis of race, color, national origin, or sex in the performance of this contract. The contractor shall carry out applicable requirements of 49 CFR part 26 in the award and administration of DOT-assisted contracts. Failure by the contractor to carry out these requirements is a material breach of this contract, which may result in the termination of this contract or such other remedy as the recipient deems appropriate, which may include, but is not limited to:

- (1) Withholding monthly progress payments;
- (2) Assessing sanctions;
- (3) Liquidated damages; and/or
- (4) Disqualifying the contractor from future bidding as non-responsible.

c. The Title VI and nondiscrimination provisions of U.S. DOT Order 1050.2A at Appendixes A and E are incorporated by reference.

11. Records and Reports: The contractor shall keep such records as necessary to document compliance with the EEO requirements. Such records shall be retained for a period of three years following the date of the final payment to the contractor for all contract work and shall be available at reasonable times and places for inspection by authorized representatives of the contracting agency and the FHWA.

a. The records kept by the contractor shall document the following:

- (1) The number and work hours of minority and non-minority group members and women employed in each work classification on the project;
- (2) The progress and efforts being made in cooperation with unions, when applicable, to increase employment opportunities for minorities and women; and
- (3) The progress and efforts being made in locating, hiring, training, qualifying, and upgrading minorities and women.

b. The contractors and subcontractors will submit an annual report to the contracting agency each July for the duration of the project indicating the number of minority, women, and non-minority group employees currently engaged in each work classification required by the contract work. This information is to be reported on [Form FHWA-1391](#). The staffing data should represent the project work force on board in all or any part of the last payroll period preceding the end of July. If on-the-job training is being required by special provision, the contractor will be required to collect and report training data. The employment data should reflect the work force on board during all or any part of the last payroll period preceding the end of July.

Chapter 3 III. NONSEGREGATED FACILITIES

The contractor must ensure that facilities provided for employees are provided in such a manner that segregation on the basis of race, color, religion, sex, sexual orientation,

gender identity, or national origin cannot result. The contractor may neither require such segregated use by written or oral policies nor tolerate such use by employee custom. The contractor's obligation extends further to ensure that its employees are not assigned to perform their services at any location under the contractor's control where the facilities are segregated. The term "facilities" includes waiting rooms, work areas, restaurants and other eating areas, time clocks, restrooms, washrooms, locker rooms and other storage or dressing areas, parking lots, drinking fountains, recreation or entertainment areas, transportation, and housing provided for employees. The contractor shall provide separate or single-user restrooms and necessary dressing or sleeping areas to assure privacy between sexes.

Chapter 4 IV. DAVIS-BACON AND RELATED ACT PROVISIONS

1. Minimum wages

a. All laborers and mechanics employed or working upon the site of the work, will be paid unconditionally and not less often than once a week, and without subsequent deduction or rebate on any account (except such payroll deductions as are permitted by regulations issued by the Secretary of Labor under the Copeland Act (29 CFR part 3)), the full amount of wages and bona fide fringe benefits (or cash equivalents thereof) due at time of payment computed at rates not less than those contained in the wage determination of the Secretary of Labor which is attached hereto and made a part hereof, regardless of any contractual relationship which may be alleged to exist between the contractor and such laborers and mechanics.

Contributions made or costs reasonably anticipated for bona fide fringe benefits under section 1(b)(2) of the Davis-Bacon Act on behalf of laborers or mechanics are considered wages paid to such laborers or mechanics, subject to the provisions of paragraph 1.d. of this section; also, regular contributions made or costs incurred for more than a weekly period (but not less often than quarterly) under plans, funds, or programs which cover the particular weekly period, are deemed to be constructively made or incurred during such weekly period. Such laborers and mechanics shall be paid the appropriate wage rate and fringe benefits on the wage determination for the classification of work actually performed, without regard to skill, except as provided in 29 CFR 5.5(a)(4). Laborers or mechanics performing work in more than one classification may be compensated at the rate specified for each classification for the time actually worked therein: Provided, That the employer's payroll records accurately set forth the time spent in each classification in which work is performed. The wage determination (including any additional classification and wage rates conformed under paragraph 1.b. of this section) and the Davis-Bacon poster (WH-1321) shall be posted at all times by the contractor and its subcontractors at the site of the work in a prominent and accessible place where it can be easily seen by the workers.

b. (1) The contracting officer shall require that any class of laborers or mechanics, including helpers, which is not listed in the wage determination and which is to be employed under the contract shall be classified in conformance with the wage determination. The contracting officer shall approve an additional classification and wage rate and fringe benefits therefore only when the following criteria have been met:

(i) The work to be performed by the classification requested is not performed by a classification in the wage determination; and

(ii) The classification is utilized in the area by the construction industry; and

(iii) The proposed wage rate, including any bona fide fringe benefits, bears a reasonable relationship to the wage rates contained in the wage determination.

(2) If the contractor and the laborers and mechanics to be employed in the classification (if known), or their representatives, and the contracting officer agree on the classification and wage rate (including the amount designated for fringe benefits where appropriate), a report of the action taken shall be sent by the contracting officer to the Administrator of the Wage and Hour Division, Employment Standards Administration, U.S. Department of Labor, Washington, DC 20210. The Administrator, or an authorized representative, will approve, modify, or disapprove every additional classification action within 30 days of receipt and so advise the contracting officer or will notify the contracting officer within the 30-day period that additional time is necessary.

(3) In the event the contractor, the laborers or mechanics to be employed in the classification or their representatives, and the contracting officer do not agree on the proposed classification and wage rate (including the amount designated for fringe benefits, where appropriate), the contracting officer shall refer the questions, including the views of all interested parties and the recommendation of the contracting officer, to the Wage and Hour Administrator for determination. The Wage and Hour Administrator, or an authorized representative, will issue a determination within 30 days of receipt and so advise the contracting officer or will notify the contracting officer within the 30-day period that additional time is necessary.

(4) The wage rate (including fringe benefits where appropriate) determined pursuant to paragraphs 1.b.(2) or 1.b.(3) of this section, shall be paid to all workers performing work in the classification under this contract from the first day on which work is performed in the classification.

c. Whenever the minimum wage rate prescribed in the contract for a class of laborers or mechanics includes a fringe benefit which is not expressed as an hourly rate, the contractor shall either pay the benefit as stated in the wage determination or shall pay another bona fide fringe benefit or an hourly cash equivalent thereof.

d. If the contractor does not make payments to a trustee or other third person, the contractor may consider as part of the wages of any laborer or mechanic the amount of any costs reasonably anticipated in providing bona fide fringe benefits under a plan or program, Provided, That the Secretary of Labor has found, upon the written request of the contractor, that the applicable standards of the Davis-Bacon Act have been met. The Secretary of Labor may require the contractor to set aside in a separate account assets for the meeting of obligations under the plan or program.

2. Withholding

The contracting agency shall upon its own action or upon written request of an authorized representative of the Department of Labor, withhold or cause to be withheld from the contractor under this contract, or any other Federal contract with the same prime contractor, or any other federally-assisted contract subject to Davis-Bacon prevailing wage requirements, which is held by the same prime contractor, so much of the accrued payments or advances as may be considered necessary to pay laborers

and mechanics, including apprentices, trainees, and helpers, employed by the contractor or any subcontractor the full amount of wages required by the contract. In the event of failure to pay any laborer or mechanic, including any apprentice, trainee, or helper, employed or working on the site of the work, all or part of the wages required by the contract, the contracting agency may, after written notice to the contractor, take such action as may be necessary to cause the suspension of any further payment, advance, or guarantee of funds until such violations have ceased.

3. Payrolls and basic records

a. Payrolls and basic records relating thereto shall be maintained by the contractor during the course of the work and preserved for a period of three years thereafter for all laborers and mechanics working at the site of the work. Such records shall contain the name, address, and social security number of each such worker, his or her correct classification, hourly rates of wages paid (including rates of contributions or costs anticipated for bona fide fringe benefits or cash equivalents thereof of the types described in section 1(b)(2)(B) of the Davis-Bacon Act), daily and weekly number of hours worked, deductions made and actual wages paid. Whenever the Secretary of Labor has found under 29 CFR 5.5(a)(1)(iv) that the wages of any laborer or mechanic include the amount of any costs reasonably anticipated in providing benefits under a plan or program described in section 1(b)(2)(B) of the Davis-Bacon Act, the contractor shall maintain records which show that the commitment to provide such benefits is enforceable, that the plan or program is financially responsible, and that the plan or program has been communicated in writing to the laborers or mechanics affected, and records which show the costs anticipated or the actual cost incurred in providing such benefits. Contractors employing apprentices or trainees under approved programs shall maintain written evidence of the registration of apprenticeship programs and certification of trainee programs, the registration of the apprentices and trainees, and the ratios and wage rates prescribed in the applicable programs.

b. (1) The contractor shall submit weekly for each week in which any contract work is performed a copy of all payrolls to the contracting agency. The payrolls submitted shall set out accurately and completely all of the information required to be maintained under 29 CFR 5.5(a)(3)(i), except that full social security numbers and home addresses shall not be included on weekly transmittals. Instead the payrolls shall only need to include an individually identifying number for each employee (e.g. , the last four digits of the employee's social security number). The required weekly payroll information may be submitted in any form desired. Optional Form WH-347 is available for this purpose from the Wage and Hour Division Web site at <http://www.dol.gov/esa/whd/forms/wh347instr.htm> or its successor site. The prime contractor is responsible for the submission of copies of payrolls by all subcontractors. Contractors and subcontractors shall maintain the full social security number and current address of each covered worker, and shall provide them upon request to the contracting agency for transmission to the State DOT, the FHWA or the Wage and Hour Division of the Department of Labor for purposes of an investigation or audit of compliance with prevailing wage requirements. It is not a violation of this section for a prime contractor to require a subcontractor to provide addresses and social security numbers to the prime contractor for its own records, without weekly submission to the contracting agency.

(2) Each payroll submitted shall be accompanied by a "Statement of Compliance," signed by the contractor or subcontractor or his or her agent who pays or supervises the payment of the persons employed under the contract and shall certify the following:

(i) That the payroll for the payroll period contains the information required to be provided under §5.5 (a)(3)(ii) of Regulations, 29 CFR part 5, the appropriate information is being maintained under §5.5 (a)(3)(i) of Regulations, 29 CFR part 5, and that such information is correct and complete;

(ii) That each laborer or mechanic (including each helper, apprentice, and trainee) employed on the contract during the payroll period has been paid the full weekly wages earned, without rebate, either directly or indirectly, and that no deductions have been made either directly or indirectly from the full wages earned, other than permissible deductions as set forth in Regulations, 29 CFR part 3;

(iii) That each laborer or mechanic has been paid not less than the applicable wage rates and fringe benefits or cash equivalents for the classification of work performed, as specified in the applicable wage determination incorporated into the contract.

(3) The weekly submission of a properly executed certification set forth on the reverse side of Optional Form WH-347 shall satisfy the requirement for submission of the "Statement of Compliance" required by paragraph 3.b.(2) of this section.

(4) The falsification of any of the above certifications may subject the contractor or subcontractor to civil or criminal prosecution under section 1001 of title 18 and section 231 of title 31 of the United States Code.

c. The contractor or subcontractor shall make the records required under paragraph 3.a. of this section available for inspection, copying, or transcription by authorized representatives of the contracting agency, the State DOT, the FHWA, or the Department of Labor, and shall permit such representatives to interview employees during working hours on the job. If the contractor or subcontractor fails to submit the required records or to make them available, the FHWA may, after written notice to the contractor, the contracting agency or the State DOT, take such action as may be necessary to cause the suspension of any further payment, advance, or guarantee of funds. Furthermore, failure to submit the required records upon request or to make such records available may be grounds for debarment action pursuant to 29 CFR 5.12.

4. Apprentices and trainees

a. Apprentices (programs of the USDOL).

Apprentices will be permitted to work at less than the predetermined rate for the work they performed when they are employed pursuant to and individually registered in a bona fide apprenticeship program registered with the U.S. Department of Labor, Employment and Training Administration, Office of Apprenticeship Training, Employer and Labor Services, or with a State Apprenticeship Agency recognized by the Office, or if a person is employed in his or her first 90 days of probationary employment as an apprentice in such an apprenticeship program, who is not individually registered in the program, but who has been certified by the Office of Apprenticeship Training, Employer and Labor Services or a State Apprenticeship Agency (where appropriate) to be eligible for probationary employment as an apprentice.

The allowable ratio of apprentices to journeymen on the job site in any craft classification shall not be greater than the ratio permitted to the contractor as to the entire work force under the registered program. Any worker listed on a payroll at an apprentice wage rate, who is not registered or otherwise employed as stated above, shall be paid not less than the applicable wage rate on the wage determination for the classification of work actually performed. In addition, any apprentice performing work on the job site in excess of the ratio permitted under the registered program shall be paid not less than the applicable wage rate on the wage determination for the work actually performed. Where a contractor is performing construction on a project in a locality other than that in which its program is registered, the ratios and wage rates (expressed in percentages of the journeyman's hourly rate) specified in the contractor's or subcontractor's registered program shall be observed.

Every apprentice must be paid at not less than the rate specified in the registered program for the apprentice's level of progress, expressed as a percentage of the journeymen hourly rate specified in the applicable wage determination. Apprentices shall be paid fringe benefits in accordance with the provisions of the apprenticeship program. If the apprenticeship program does not specify fringe benefits, apprentices must be paid the full amount of fringe benefits listed on the wage determination for the applicable classification. If the Administrator determines that a different practice prevails for the applicable apprentice classification, fringes shall be paid in accordance with that determination.

In the event the Office of Apprenticeship Training, Employer and Labor Services, or a State Apprenticeship Agency recognized by the Office, withdraws approval of an apprenticeship program, the contractor will no longer be permitted to utilize apprentices at less than the applicable predetermined rate for the work performed until an acceptable program is approved.

b. Trainees (programs of the USDOL).

Except as provided in 29 CFR 5.16, trainees will not be permitted to work at less than the predetermined rate for the work performed unless they are employed pursuant to and individually registered in a program which has received prior approval, evidenced by formal certification by the U.S. Department of Labor, Employment and Training Administration.

The ratio of trainees to journeymen on the job site shall not be greater than permitted under the plan approved by the Employment and Training Administration.

Every trainee must be paid at not less than the rate specified in the approved program for the trainee's level of progress, expressed as a percentage of the journeyman hourly rate specified in the applicable wage determination. Trainees shall be paid fringe benefits in accordance with the provisions of the trainee program. If the trainee program does not mention fringe benefits, trainees shall be paid the full amount of fringe benefits listed on the wage determination unless the Administrator of the Wage and Hour Division determines that there is an apprenticeship program associated with the corresponding journeyman wage rate on the wage determination which provides for less than full fringe benefits for apprentices. Any employee listed on the payroll at a trainee rate who is not registered and participating in a training plan approved by the Employment and Training Administration shall be paid not less than the applicable wage rate on the wage determination for the classification of work actually performed. In addition, any trainee

performing work on the job site in excess of the ratio permitted under the registered program shall be paid not less than the applicable wage rate on the wage determination for the work actually performed.

In the event the Employment and Training Administration withdraws approval of a training program, the contractor will no longer be permitted to utilize trainees at less than the applicable predetermined rate for the work performed until an acceptable program is approved.

c. Equal employment opportunity. The utilization of apprentices, trainees and journeymen under this part shall be in conformity with the equal employment opportunity requirements of Executive Order 11246, as amended, and 29 CFR part 30.

d. Apprentices and Trainees (programs of the U.S. DOT).

Apprentices and trainees working under apprenticeship and skill training programs which have been certified by the Secretary of Transportation as promoting EEO in connection with Federal-aid highway construction programs are not subject to the requirements of paragraph 4 of this Section IV. The straight time hourly wage rates for apprentices and trainees under such programs will be established by the particular programs. The ratio of apprentices and trainees to journeymen shall not be greater than permitted by the terms of the particular program.

5. Compliance with Copeland Act requirements. The contractor shall comply with the requirements of 29 CFR part 3, which are incorporated by reference in this contract.

6. Subcontracts. The contractor or subcontractor shall insert Form FHWA-1273 in any subcontracts and also require the subcontractors to include Form FHWA-1273 in any lower tier subcontracts. The prime contractor shall be responsible for the compliance by any subcontractor or lower tier subcontractor with all the contract clauses in 29 CFR 5.5.

7. Contract termination: debarment. A breach of the contract clauses in 29 CFR 5.5 may be grounds for termination of the contract, and for debarment as a contractor and a subcontractor as provided in 29 CFR 5.12.

8. Compliance with Davis-Bacon and Related Act requirements. All rulings and interpretations of the Davis-Bacon and Related Acts contained in 29 CFR parts 1, 3, and 5 are herein incorporated by reference in this contract.

9. Disputes concerning labor standards. Disputes arising out of the labor standards provisions of this contract shall not be subject to the general disputes clause of this contract. Such disputes shall be resolved in accordance with the procedures of the Department of Labor set forth in 29 CFR parts 5, 6, and 7. Disputes within the meaning of this clause include disputes between the contractor (or any of its subcontractors) and the contracting agency, the U.S. Department of Labor, or the employees or their representatives.

10. Certification of eligibility.

a. By entering into this contract, the contractor certifies that neither it (nor he or she) nor any person or firm who has an interest in the contractor's firm is a person or firm ineligible to be awarded Government contracts by virtue of section 3(a) of the Davis-Bacon Act or 29 CFR 5.12(a)(1).

b. No part of this contract shall be subcontracted to any person or firm ineligible for award of a Government contract by virtue of section 3(a) of the Davis-Bacon Act or 29 CFR 5.12(a)(1).

The penalty for making false statements is prescribed in the U.S. Criminal Code, 18 U.S.C. 1001.

Chapter 5 V. CONTRACT WORK HOURS AND SAFETY STANDARDS ACT

1. Overtime requirements. No contractor or subcontractor contracting for any part of the contract work which may require or involve the employment of laborers or mechanics shall require or permit any such laborer or mechanic in any workweek in which he or she is employed on such work to work in excess of forty hours in such workweek unless such laborer or mechanic receives compensation at a rate not less than one and one-half times the basic rate of pay for all hours worked in excess of forty hours in such workweek.

2. Violation; liability for unpaid wages; liquidated damages. In the event of any violation of the clause set forth in paragraph (1.) of this section, the contractor and any subcontractor responsible therefor shall be liable for the unpaid wages. In addition, such contractor and subcontractor shall be liable to the United States (in the case of work done under contract for the District of Columbia or a territory, to such District or to such territory), for liquidated damages. Such liquidated damages shall be computed with respect to each individual laborer or mechanic, including watchmen and guards, employed in violation of the clause set forth in paragraph (1.) of this section, in the sum of \$10 for each calendar day on which such individual was required or permitted to work in excess of the standard workweek of forty hours without payment of the overtime wages required by the clause set forth in paragraph (1.) of this section.

3. Withholding for unpaid wages and liquidated damages. The FHWA or the contacting agency shall upon its own action or upon written request of an authorized representative of the Department of Labor withhold or cause to be withheld, from any moneys payable on account of work performed by the contractor or subcontractor under any such contract or any other Federal contract with the same prime contractor, or any other federally-assisted contract subject to the Contract Work Hours and Safety Standards Act, which is held by the same prime contractor, such sums as may be determined to be necessary to satisfy any liabilities of such contractor or subcontractor for unpaid wages and liquidated damages as provided in the clause set forth in paragraph (2.) of this section.

4. Subcontracts. The contractor or subcontractor shall insert in any subcontracts the clauses set forth in paragraph (1.) through (4.) of this section and also a clause requiring the subcontractors to include these clauses in any lower tier subcontracts. The prime contractor shall be responsible for compliance by any subcontractor or lower tier subcontractor with the clauses set forth in paragraphs (1.) through (4.) of this section.

Chapter 6 VI. SUBLETTING OR ASSIGNING THE CONTRACT

1. The contractor shall perform with its own organization contract work amounting to not less than 30 percent (or a greater percentage if specified elsewhere in the contract) of

the total original contract price, excluding any specialty items designated by the contracting agency. Specialty items may be performed by subcontract and the amount of any such specialty items performed may be deducted from the total original contract price before computing the amount of work required to be performed by the contractor's own organization (23 CFR 635.116).

a. The term "perform work with its own organization" refers to workers employed or leased by the prime contractor, and equipment owned or rented by the prime contractor, with or without operators. Such term does not include employees or equipment of a subcontractor or lower tier subcontractor, agents of the prime contractor, or any other assignees. The term may include payments for the costs of hiring leased employees from an employee leasing firm meeting all relevant Federal and State regulatory requirements. Leased employees may only be included in this term if the prime contractor meets all of the following conditions:

- (1) the prime contractor maintains control over the supervision of the day-to-day activities of the leased employees;
- (2) the prime contractor remains responsible for the quality of the work of the leased employees;
- (3) the prime contractor retains all power to accept or exclude individual employees from work on the project; and
- (4) the prime contractor remains ultimately responsible for the payment of predetermined minimum wages, the submission of payrolls, statements of compliance and all other Federal regulatory requirements.

b. "Specialty Items" shall be construed to be limited to work that requires highly specialized knowledge, abilities, or equipment not ordinarily available in the type of contracting organizations qualified and expected to bid or propose on the contract as a whole and in general are to be limited to minor components of the overall contract.

2. The contract amount upon which the requirements set forth in paragraph (1) of Section VI is computed includes the cost of material and manufactured products which are to be purchased or produced by the contractor under the contract provisions.

3. The contractor shall furnish (a) a competent superintendent or supervisor who is employed by the firm, has full authority to direct performance of the work in accordance with the contract requirements, and is in charge of all construction operations (regardless of who performs the work) and (b) such other of its own organizational resources (supervision, management, and engineering services) as the contracting officer determines is necessary to assure the performance of the contract.

4. No portion of the contract shall be sublet, assigned or otherwise disposed of except with the written consent of the contracting officer, or authorized representative, and such consent when given shall not be construed to relieve the contractor of any responsibility for the fulfillment of the contract. Written consent will be given only after the contracting agency has assured that each subcontract is evidenced in writing and that it contains all pertinent provisions and requirements of the prime contract.

5. The 30% self-performance requirement of paragraph (1) is not applicable to design-build contracts; however, contracting agencies may establish their own self-performance requirements.

Chapter 7 VII. SAFETY: ACCIDENT PREVENTION

1. In the performance of this contract the contractor shall comply with all applicable Federal, State, and local laws governing safety, health, and sanitation (23 CFR 635). The contractor shall provide all safeguards, safety devices and protective equipment and take any other needed actions as it determines, or as the contracting officer may determine, to be reasonably necessary to protect the life and health of employees on the job and the safety of the public and to protect property in connection with the performance of the work covered by the contract.

2. It is a condition of this contract, and shall be made a condition of each subcontract, which the contractor enters into pursuant to this contract, that the contractor and any subcontractor shall not permit any employee, in performance of the contract, to work in surroundings or under conditions which are unsanitary, hazardous or dangerous to his/her health or safety, as determined under construction safety and health standards (29 CFR 1926) promulgated by the Secretary of Labor, in accordance with Section 107 of the Contract Work Hours and Safety Standards Act (40 U.S.C. 3704).

3. Pursuant to 29 CFR 1926.3, it is a condition of this contract that the Secretary of Labor or authorized representative thereof, shall have right of entry to any site of contract performance to inspect or investigate the matter of compliance with the construction safety and health standards and to carry out the duties of the Secretary under Section 107 of the Contract Work Hours and Safety Standards Act (40 U.S.C.3704).

Chapter 8 VIII. FALSE STATEMENTS CONCERNING HIGHWAY PROJECTS

In order to assure high quality and durable construction in conformity with approved plans and specifications and a high degree of reliability on statements and representations made by engineers, contractors, suppliers, and workers on Federal-aid highway projects, it is essential that all persons concerned with the project perform their functions as carefully, thoroughly, and honestly as possible. Willful falsification, distortion, or misrepresentation with respect to any facts related to the project is a violation of Federal law. To prevent any misunderstanding regarding the seriousness of these and similar acts, Form FHWA-1022 shall be posted on each Federal-aid highway project (23 CFR 635) in one or more places where it is readily available to all persons concerned with the project:

18 U.S.C. 1020 reads as follows:

"Whoever, being an officer, agent, or employee of the United States, or of any State or Territory, or whoever, whether a person, association, firm, or corporation, knowingly makes any false statement, false representation, or false report as to the character, quality, quantity, or cost of the material used or to be used, or the quantity or quality of the work performed or to be performed, or the cost thereof in connection with the submission of plans, maps, specifications, contracts, or costs of construction on any highway or related project submitted for approval to the Secretary of Transportation; or

Whoever knowingly makes any false statement, false representation, false report or false claim with respect to the character, quality, quantity, or cost of any work performed or to be performed, or materials furnished or to be furnished, in connection with the construction of any highway or related project approved by the Secretary of Transportation; or

Whoever knowingly makes any false statement or false representation as to material fact in any statement, certificate, or report submitted pursuant to provisions of the Federal-aid Roads Act approved July 1, 1916, (39 Stat. 355), as amended and supplemented;

Shall be fined under this title or imprisoned not more than 5 years or both."

Chapter 9 IX. IMPLEMENTATION OF CLEAN AIR ACT AND FEDERAL WATER POLLUTION CONTROL ACT

By submission of this bid/proposal or the execution of this contract or subcontract, as appropriate, the bidder, proposer, Federal-aid construction contractor, subcontractor, supplier, or vendor agrees to comply with all applicable standards, orders or regulations issued pursuant to the Clean Air Act (42 U.S.C. 7401-7671q) and the Federal Water Pollution Control Act, as amended (33 U.S.C. 1251-1387). Violations must be reported to the Federal Highway Administration and the Regional Office of the Environmental Protection Agency.

Chapter 10 X. CERTIFICATION REGARDING DEBARMENT, SUSPENSION, INELIGIBILITY AND VOLUNTARY EXCLUSION

1. Instructions for Certification – First Tier Participants:

a. By signing and submitting this proposal, the prospective first tier participant is providing the certification set out below.

b. The inability of a person to provide the certification set out below will not necessarily result in denial of participation in this covered transaction. The prospective first tier participant shall submit an explanation of why it cannot provide the certification set out below. The certification or explanation will be considered in connection with the department or agency's determination whether to enter into this transaction. However, failure of the prospective first tier participant to furnish a certification or an explanation shall disqualify such a person from participation in this transaction.

c. The certification in this clause is a material representation of fact upon which reliance was placed when the contracting agency determined to enter into this transaction. If it is later determined that the prospective participant knowingly rendered an erroneous certification, in addition to other remedies available to the Federal Government, the contracting agency may terminate this transaction for cause of default.

d. The prospective first tier participant shall provide immediate written notice to the contracting agency to whom this proposal is submitted if any time the prospective first tier participant learns that its certification was erroneous when submitted or has become erroneous by reason of changed circumstances.

e. The terms "covered transaction," "debarred," "suspended," "ineligible," "participant," "person," "principal," and "voluntarily excluded," as used in this clause, are defined in 2 CFR Parts 180 and 1200. "First Tier Covered Transactions" refers to any covered transaction between a recipient or subrecipient of Federal funds and a participant (such as the prime or general contract). "Lower Tier Covered Transactions" refers to any covered transaction under a First Tier Covered Transaction (such as subcontracts). "First Tier Participant" refers to the participant who has entered into a covered transaction with a recipient or subrecipient of Federal funds (such as the prime or general contractor). "Lower Tier Participant" refers any participant who has entered into a covered transaction with a First Tier Participant or other Lower Tier Participants (such as subcontractors and suppliers).

f. The prospective first tier participant agrees by submitting this proposal that, should the proposed covered transaction be entered into, it shall not knowingly enter into any lower tier covered transaction with a person who is debarred, suspended, declared ineligible, or voluntarily excluded from participation in this covered transaction, unless authorized by the department or agency entering into this transaction.

g. The prospective first tier participant further agrees by submitting this proposal that it will include the clause titled "Certification Regarding Debarment, Suspension, Ineligibility and Voluntary Exclusion-Lower Tier Covered Transactions," provided by the department or contracting agency, entering into this covered transaction, without modification, in all lower tier covered transactions and in all solicitations for lower tier covered transactions exceeding the \$25,000 threshold.

h. A participant in a covered transaction may rely upon a certification of a prospective participant in a lower tier covered transaction that is not debarred, suspended, ineligible, or voluntarily excluded from the covered transaction, unless it knows that the certification is erroneous. A participant is responsible for ensuring that its principals are not suspended, debarred, or otherwise ineligible to participate in covered transactions. To verify the eligibility of its principals, as well as the eligibility of any lower tier prospective participants, each participant may, but is not required to, check the System for Award Management website (<https://www.sam.gov/>).

i. Nothing contained in the foregoing shall be construed to require the establishment of a system of records in order to render in good faith the certification required by this clause. The knowledge and information of the prospective participant is not required to exceed that which is normally possessed by a prudent person in the ordinary course of business dealings.

j. Except for transactions authorized under paragraph (f) of these instructions, if a participant in a covered transaction knowingly enters into a lower tier covered transaction with a person who is suspended, debarred, ineligible, or voluntarily excluded from participation in this transaction, in addition to other remedies available to the Federal Government, the department or agency may terminate this transaction for cause or default.

2. Certification Regarding Debarment, Suspension, Ineligibility and Voluntary Exclusion – First Tier Participants:

a. The prospective first tier participant certifies to the best of its knowledge and belief, that it and its principals:

(1) Are not presently debarred, suspended, proposed for debarment, declared ineligible, or voluntarily excluded from participating in covered transactions by any Federal department or agency;

(2) Have not within a three-year period preceding this proposal been convicted of or had a civil judgment rendered against them for commission of fraud or a criminal offense in connection with obtaining, attempting to obtain, or performing a public (Federal, State, or local) transaction or contract under a public transaction; violation of Federal or State antitrust statutes or commission of embezzlement, theft, forgery, bribery, falsification or destruction of records, making false statements, or receiving stolen property;

(3) Are not presently indicted for or otherwise criminally or civilly charged by a governmental entity (Federal, State or local) with commission of any of the offenses enumerated in paragraph (a)(2) of this certification; and

(4) Have not within a three-year period preceding this application/proposal had one or more public transactions (Federal, State or local) terminated for cause or default.

(5) Are not a corporation that has been convicted of a felony violation under any Federal law within the two-year period preceding this proposal; and

(6) Are not a corporation with any unpaid Federal tax liability that has been assessed, for which all judicial and administrative remedies have been exhausted, or have lapsed, and that is not being paid in a timely manner pursuant to an agreement with the authority responsible for collecting the tax liability.

b. Where the prospective participant is unable to certify to any of the statements in this certification, such prospective participant shall attach an explanation to this proposal.

3. Instructions for Certification - Lower Tier Participants:

(Applicable to all subcontracts, purchase orders, and other lower tier transactions requiring prior FHWA approval or estimated to cost \$25,000 or more - 2 CFR Parts 180 and 1200)

a. By signing and submitting this proposal, the prospective lower tier participant is providing the certification set out below.

b. The certification in this clause is a material representation of fact upon which reliance was placed when this transaction was entered into. If it is later determined that the prospective lower tier participant knowingly rendered an erroneous certification, in addition to other remedies available to the Federal Government, the department, or agency with which this transaction originated may pursue available remedies, including suspension and/or debarment.

c. The prospective lower tier participant shall provide immediate written notice to the person to which this proposal is submitted if at any time the prospective lower tier participant learns that its certification was erroneous by reason of changed circumstances.

d. The terms "covered transaction," "debarred," "suspended," "ineligible," "participant," "person," "principal," and "voluntarily excluded," as used in this clause, are defined in 2 CFR Parts 180 and 1200. You may contact the person to which this proposal is submitted for assistance in obtaining a copy of those regulations. "First Tier Covered Transactions" refers to any covered transaction between a recipient or subrecipient of Federal funds and a participant (such as the prime or general contract). "Lower Tier Covered Transactions" refers to any covered transaction under a First Tier Covered Transaction (such as subcontracts). "First Tier Participant" refers to the participant who has entered into a covered transaction with a recipient or subrecipient of Federal funds (such as the prime or general contractor). "Lower Tier Participant" refers any participant who has entered into a covered transaction with a First Tier Participant or other Lower Tier Participants (such as subcontractors and suppliers).

e. The prospective lower tier participant agrees by submitting this proposal that, should the proposed covered transaction be entered into, it shall not knowingly enter into any lower tier covered transaction with a person who is debarred, suspended, declared ineligible, or voluntarily excluded from participation in this covered transaction, unless authorized by the department or agency with which this transaction originated.

f. The prospective lower tier participant further agrees by submitting this proposal that it will include this clause titled "Certification Regarding Debarment, Suspension, Ineligibility and Voluntary Exclusion-Lower Tier Covered Transaction," without modification, in all lower tier covered transactions and in all solicitations for lower tier covered transactions exceeding the \$25,000 threshold.

g. A participant in a covered transaction may rely upon a certification of a prospective participant in a lower tier covered transaction that is not debarred, suspended, ineligible, or voluntarily excluded from the covered transaction, unless it knows that the certification is erroneous. A participant is responsible for ensuring that its principals are not suspended, debarred, or otherwise ineligible to participate in covered transactions. To verify the eligibility of its principals, as well as the eligibility of any lower tier prospective participants, each participant may, but is not required to, check the System for Award Management website (<https://www.sam.gov/>), which is compiled by the General Services Administration.

h. Nothing contained in the foregoing shall be construed to require establishment of a system of records in order to render in good faith the certification required by this clause. The knowledge and information of participant is not required to exceed that which is normally possessed by a prudent person in the ordinary course of business dealings.

i. Except for transactions authorized under paragraph e of these instructions, if a participant in a covered transaction knowingly enters into a lower tier covered transaction with a person who is suspended, debarred, ineligible, or voluntarily excluded from participation in this transaction, in addition to other remedies available to the Federal Government, the department or agency with which this transaction originated may pursue available remedies, including suspension and/or debarment. * * * *

Certification Regarding Debarment, Suspension, Ineligibility and Voluntary Exclusion--Lower Tier Participants:

1. The prospective lower tier participant certifies, by submission of this proposal, that neither it nor its principals:

(a) is presently debarred, suspended, proposed for debarment, declared ineligible, or voluntarily excluded from participating in covered transactions by any Federal department or agency;

(b) is a corporation that has been convicted of a felony violation under any Federal law within the two-year period preceding this proposal; and

(c) is a corporation with any unpaid Federal tax liability that has been assessed, for which all judicial and administrative remedies have been exhausted, or have lapsed, and that is not being paid in a timely manner pursuant to an agreement with the authority responsible for collecting the tax liability.

2. Where the prospective lower tier participant is unable to certify to any of the statements in this certification, such prospective participant shall attach an explanation to this proposal.

Chapter 11 XI. CERTIFICATION REGARDING USE OF CONTRACT FUNDS FOR LOBBYING

1. The prospective participant certifies, by signing and submitting this bid or proposal, to the best of his or her knowledge and belief, that:

a. No Federal appropriated funds have been paid or will be paid, by or on behalf of the undersigned, to any person for influencing or attempting to influence an officer or employee of any Federal agency, a Member of Congress, an officer or employee of Congress, or an employee of a Member of Congress in connection with the awarding of any Federal contract, the making of any Federal grant, the making of any Federal loan, the entering into of any cooperative agreement, and the extension, continuation, renewal, amendment, or modification of any Federal contract, grant, loan, or cooperative agreement.

b. If any funds other than Federal appropriated funds have been paid or will be paid to any person for influencing or attempting to influence an officer or employee of any Federal agency, a Member of Congress, an officer or employee of Congress, or an employee of a Member of Congress in connection with this Federal contract, grant, loan, or cooperative agreement, the undersigned shall complete and submit Standard Form-LLL, "Disclosure Form to Report Lobbying," in accordance with its instructions.

2. This certification is a material representation of fact upon which reliance was placed when this transaction was made or entered into. Submission of this certification is a prerequisite for making or entering into this transaction imposed by 31 U.S.C. 1352. Any person who fails to file the required certification shall be subject to a civil penalty of not less than \$10,000 and not more than \$100,000 for each such failure.

3. The prospective participant also agrees by submitting its bid or proposal that the participant shall require that the language of this certification be included in all lower tier subcontracts, which exceed \$100,000 and that all such recipients shall certify and disclose accordingly.

Chapter 12 XII. USE OF UNITED STATES-FLAG VESSELS:

1. To utilize privately owned United States-flag commercial vessels to ship at least 50 percent of the gross tonnage (computed separately for dry bulk carriers, dry cargo liners, and tankers) involved, whenever shipping any equipment, material, or commodities pursuant to this contract, to the extent such vessels are available at fair and reasonable rates for United States-flag commercial vessels.

2. To furnish within 20 days following the date of loading for shipments originating within the United States or within 30 working days following the date of loading for shipments originating outside the United States, a legible copy of a rated, 'on-board' commercial ocean bill-of-lading in English for each shipment of cargo described in paragraph (b) (1) of this section to both the Contracting Officer (through the prime contractor in the case of subcontractor bills-of-lading) and to the Office of Cargo and Commercial Sealift (MAR-620), Maritime Administration, Washington, DC 20590. (MARAD requires copies of the ocean carrier's (master) bills of lading, certified onboard, dated, with rates and charges. These bills of lading may contain business sensitive information and therefore may be submitted directly to MARAD by the Ocean Transportation Intermediary on behalf of the contractor).

CHECKLIST FOR BIDDERS

The following information is required of all Bidders:

- _____ Signed Proposal Sheet
- _____ Completed Bid Sheet(s)
- _____ Completed Information Required of Bidders Form
- _____ Acknowledgement of each addendum issued by the City, if any, with complete signed and dated copies of each addendum attached
- _____ Executed Statement Acknowledging Penal and Civil Penalties Concerning the Contractor's Licensing Law
- _____ Designation of Subcontractors
- _____ Complete Contractors Industrial Safety Record
- _____ Bid Security
- _____ Non-Collusion Affidavit
- _____ Completed and Executed Bidder's Questionnaire

INTENTIONALLY LEFT BLANK

PROPOSAL

San Pablo Avenue Pavement Rehabilitation

TO THE CITY COUNCIL OF THE CITY OF PINOLE

The undersigned, as bidder, declares that: (1) this proposal is made without collusion with any other person, firm or corporation, and that the only persons or parties interested as principals are those named herein; (2) bidder has carefully examined the project plans, specifications, instructions to bidders, proposal, notice to contractors and all other information furnished therefore and the site of the proposed work; (3) bidder has investigated and is satisfied as to the conditions to be encountered, the character, quality and quantities of work to be performed and materials to be furnished. Furthermore, bidder agrees that submission of this proposal shall be conclusive evidence that such examination and investigation have been made and agrees, in the event this contract be awarded to bidder, to enter into a contract with the CITY OF PINOLE, to perform said proposed work in accordance with the plans, if any, and the terms of the specifications, in the time and manner therein prescribed, and to furnish or provide all materials, labor, tools, equipment, apparatus and other means necessary so to do, except such thereof as may otherwise be furnished or provided under the terms of said specifications, for the following stated unit prices or lump-sum price as submitted on the Schedule attached hereto:

The bidder shall submit as part of this proposal a completed copy of the Contractor's Industrial Safety Record.

Accompanying this proposal is _____ (Insert "\$_____ cash," "Cashier's Check," "certified check," or "Bid Bond," as the case may be) in the amount equal to at least ten percent (10%) of the total aggregate bid price hereof based on the quantities shown and the unit prices quoted in the **Bid Sheets**.

The undersigned further agrees that should he/she be awarded the contract on the basis hereof and thereafter, defaults in executing the required contract, with necessary bonds and documents, within ten (10) days, not including Sundays and legal holidays, after having received notice that the contract has been awarded and is ready for signature, the proceeds of the security accompanying his bid shall become the property of the CITY OF PINOLE and this proposal and the acceptance thereof may be considered null and void.

Licensed in accordance with an act providing for the registration of contractors, California Contractor's License No. _____, Class _____, Expiration Date _____.

City of Pinole Business License Number _____

Signature(s) of bidder: _____

If an individual, so state. If a firm or co-partnership, state the firm name and give the names of all individual co-partners composing the firm. If a corporation, state legal name of corporation, also names of president, secretary, treasurer, and manager thereof. Two notarized officer's signatures and the corporate seal are required for corporations.

Legal Business Name: _____

Address: _____

Telephone: _____

Contact: _____

Proposals which do not show the number and date of the Bidder's License under the provisions of Chapter 9 of Division 3 of the Business & Professional Code will be rejected. To be submitted with each bid to contract for **San Pablo Avenue Pavement Rehabilitation.**

Bid Date _____

This information must include all construction work undertaken in the State of California by the bidder and partnership joint venture or corporation that any principal of the bidder participated in as a principal or owner for the last five calendar years and the current calendar year prior to the date of bid submittal. Separate information shall be submitted for each particular partnership, joint venture, corporate or individual bidder. The bidder may attach any additional information or explanation of data which bidder would like to be taken into consideration in evaluating the safety record. An explanation must be attached of the circumstances surrounding any and all fatalities.

**CITY OF PINOLE
 BID SCHEDULE**

NAME OF COMPANY: _____

To the Honorable Mayor and Members of the City Council:

In compliance with the Notice Inviting Sealed Bids, the undersigned hereby agrees to enter into a contract to furnish all labor, materials, equipment and supplies for the project identified as **San Pablo Avenue Pavement Rehabilitation** Project in accordance with the specifications and plans in the Contract Documents which are on file in the office of the CITY ENGINEER of the City of Pinole to the satisfaction and under the direction of the CITY ENGINEER at the following prices:

SAN PABLO AVENUE PAVEMENT REHABILITATION

ITEM No.	DESCRIPTION	QTY.	UNIT	UNIT PRICE	TOTAL
1	Mobilization	1	LS		
2	Traffic Management	1	LS		
3	Construction Area Signs	6	EA		
4	Roadside Signs	8	EA		
5	Adjust AT&T MH Frame & Cover To Grade (Revocable)	4	EA		
6	Adjust WCWD MH Frame & Cover To Grade (Revocable)	7	EA		
7	Adjust City MH Frame & Cover To Grade (Revocable)	1	EA		
8	Adjust EBMUD Valve Cover To Grade (Revocable)	22	EA		
9	Adjust PG&E Gas Valve Cover To Grade (Revocable)	7	EA		
10	Adjust WCWD Rodding Cover To Grade (Revocable)	2	EA		
11	Adjust Drain Inlet/Catch Basin To Grade	1	EA		
12	Adjust City Monument Frame & Cover To Grade	3	EA		
13.1	Base Failure Repair - 4" Digout	1,000	SF		
13.2	Base Failure Repair - 11" Digout	2,200	SF		
14.1	5" Asphalt Pavement Cold Planing	3,202	SY		
14.2	2-1/4" Asphalt Pavement Cold Planing	16,826	SY		
15	Hot Mix Asphalt (Type A)	2,987	TON		
16	Striping, Detail 9	4,176	LF		
17	Striping, Detail 38	720	LF		
18	Striping, Detail 25A	130	LF		

19	White Stop Bar & Crosswalk Lines (Thermo) Non-Skid	2,408	LF		
20	White Pavement Markings (Thermo) Non-Skid	701	SF		
21	Two-Way Reflective Pavement Marker (Blue)	6	EA		
22	Curb Paint (Two Coats)	1,138	LF		
ITEM No.	DESCRIPTION	QTY.	UNIT	UNIT PRICE	TOTAL
23	Remove And Replace Vehicle Loop Detector	36	EA		
24	Remove Concrete & Base	3,329	SF		
25	Concrete Curb Ramps	17	EA		
26	Water Pollution Control	1	LS		
27	Wooden Retaining Wall	405	LF		

TOTAL PRICE OF BASE BID = _____

BID TOTAL AMOUNT IN WORDS = _____

The undersigned further agrees to deliver and to complete the work within _____ **working days**, from the date of issuance, by the Public Works Department, of notice to proceed with the work, and within _____ days of the date of mailing of the notice of award, to enter into and execute and provide to the City the necessary contract with the necessary bonds and other required documents, and in case of default in executing the necessary contract within the time fixed by the Instructions to Bidders, the bidder's security accompanying this bid shall become the property of and be forfeited to the City of Pinole.

Prime Contractor _____

License # _____ Expiration Date _____

Contractor's License number and expiration date are herein stated under penalty of perjury.

By: _____ Title: _____

Dated this _____ day of _____, 20_____

INFORMATION REQUIRED OF BIDDER

The bidder is required to supply the following information: (Additional sheets may be attached if necessary.)

(1) Address: _____

(2) Telephone: _____

(3) Type of firm - Individual, Partnership, or Corporation:

(4) Corporation organized under the laws of the State of

(5) Contractor's license number and class:

(6) List the names and addresses of all members of the firm or names and titles of all officers of the corporation:

(7) Number of years experience as a contractor in construction work _____

(8) List at least three similar projects completed as of recent date:

Contract Amount	Class of Work	Date Completed	Name, Address of Owner, & Telephone #

- (9) List the name and address of such subcontractor who will perform work in or about the work of improvement and indicate what part of the work will be done by each such contractor:

NAME _____ TYPE OF WORK _____

ADDRESS _____

NAME _____ TYPE OF WORK _____

ADDRESS _____

- (10) List the name of the person who inspected the site of the proposed work for your firm:

- (11) NOTE: Upon request of the City, the bidder shall furnish evidence showing a notarized financial statement, financial data, construction experience, or other information.

- (12) Bidder shall be properly licensed in accordance with Business and Professional Code Section 7028 at the time of the Business and Professional Code shall be considered non-responsive and his bid shall be rejected.

- (13) Within 24 hours of the bid opening, the apparent low bidder shall submit the following information for each subcontractor:

Sub-Contractor Name _____ License No. and Class

Subcontractors License verified with California Contractor's State License Board on

by _____ Title

Sub-Contractor Name _____ License No. and Class

Subcontractors License verified with California Contractor's State License Board on

by _____ Title

**STATEMENT ACKNOWLEDGING PENAL AND CIVIL PENALTIES
CONCERNING THE CONTRACTORS' LICENSING LAWS**

**[Business & Professions Code 7028.15]
[Public Contract Code 20103.5]**

I, the undersigned, certify that I am aware of the following provisions of California law and that I, or the entity on whose behalf this certification is given, hold a currently valid California contractor's license as set forth below:

Business & Professions Code 7028.15:

- (a) **It is a misdemeanor for any person to submit a bid to a public agency in order to engage in the business or act in the capacity of a contractor within this state without having a license therefore**, except in any of the following cases:
- (1) The person is particularly exempted from this chapter.
 - (2) The bid is submitted on a state project governed by Section 10164 of the Public Contract Code or on any local agency project governed by Section 20103.5 of the Public Contract Code.
- (b) If a person has been previously convicted of the offense described in this section, the court shall impose a fine of 20 percent of the price of the contract under which the unlicensed person performed contracting work, or four thousand five hundred dollars (\$4,500), whichever is greater, or imprisonment in the county jail for not less than 10 days nor more than six months, or both.
- In the event the person performing the contracting work has agreed to furnish materials and labor on an hourly basis, "the price of the contract" for the purposes of this subdivision means the aggregate sum of the cost of materials and labor furnished and the cost of completing the work to be performed.
- (c) This section shall not apply to a joint venture license, as required by Section 7029.1. However, at the time of making a bid as a joint venture, each person submitting the bid shall be subject to this section with respect to his or her individual licensure.
- (d) This section shall not affect the right or ability of a licensed architect, land surveyor, or registered professional engineer to form joint ventures with licensed contractor to render services within the scope of their respective practices.
- (e) Unless one of the foregoing exceptions applies, a bid submitted to a public agency by a contractor who is not licensed in accordance with this chapter shall be considered non-responsive and shall be rejected by the public agency. Unless one of the foregoing exceptions applies, a local public agency shall, before awarding a contract or issuing a purchase order, verify that the contractor was properly licensed when the contractor submitted the bid. Notwithstanding any other provision of law, unless one of the foregoing

exceptions applies, the registrar may issue a citation to any public officer or employee of a public entity who knowingly awards a contract or issues a purchase order to a contractor who is not licensed pursuant to this chapter. The amount of civil penalties, appeal, and finality of such citations shall be subject to Sections 7028.7 to 7028.13 inclusive. **Any contract awarded to, or any purchase order issued to, a contractor who is not licensed pursuant to this chapter is void.**

- (f) Any compliance or noncompliance with subdivision (e) of this section, as added by Chapter 863 of the Statutes of 1989, shall not invalidate any contract or bid awarded by a public agency during which time that subdivision was in effect.
- (g) A public employee or officer shall not be subject to a citation pursuant to this section if the public employee, officer, or employing agency made an inquiry to the board for the purposes of verifying the license status of any person or contractor and the board failed to respond to the inquiry within three business days. For purposes of this section, a telephone response by the board shall be deemed sufficient.

Public Contract Code 20103.5:

In all contracts subject to this part where federal funds are involved, no bid submitted shall be invalidated by the failure of the bidder to be licensed in accordance with the laws of this state. However, at the time the contract is awarded, the contractor shall be properly licensed in accordance with the laws of this state. The first payment for work or material under any contract shall not be made unless and until the Registrar of Contractors verifies to the agency that the records of the Contractor's State License Board indicate that the contractor was properly licensed at the time the contract was awarded. Any bidder or contractor not so licensed shall be subject to all legal penalties imposed by law including, but not limited to, any appropriate disciplinary action by the Contractor's State License Board. The agency shall include a statement to that effect in the standard form of prequalification questionnaire and financial statement. Failure of the bidder to obtain proper and adequate licensing for an award of a contract shall constitute a failure to execute the contract and shall result in the forfeiture of the security of the bidder.

License No.: _____

Class: _____

Expiration Date: _____

Date: _____

Signature: _____

DESIGNATION OF SUBCONTRACTORS

[Public Contract Code section 4104 and Title 49, Section 26.11 of the Code of Federal Regulations]

Public Contract Code section 4104 provides as follows:

Any officer, department, board or commission taking bids for the construction of any public work or improvement shall provide in the specifications prepared for the work or improvement or in the general conditions under which bids will be received for the doing of the work incident to the public work or improvement that any person making a bid or offer to perform the work, shall, in his or her bid or offer, set forth:

(a)(1) The name and the location of the place of business of each subcontractor who will perform work or labor or render service to the prime contractor in or about the construction of the work or improvement, or a subcontractor licensed by the State of California who, under subcontract to the prime contractor, specially fabricates and installs a portion of the work or improvement according to detailed drawings contained in the plans and specifications, in an amount in excess of one-half of 1 percent of the prime contractor's total bid or, in the case of bids or offers for the construction of streets or highways, including bridges, in excess of one-half of 1 percent of the prime contractor's total bid or ten thousand dollars (\$10,000), whichever is greater.

(2)(A) Subject to subparagraph (B), any information requested by the officer, department, board, or commission concerning any subcontractor who the prime contractor is required to list under this subdivision, other than the subcontractor's name and location of business, may be submitted by the prime contractor up to 24 hours after the deadline established by the officer, department, board, or commission for receipt of bids by prime contractors.

(B) A state or local agency may implement subparagraph (A) at its option.

(b) The portion of the work that will be done by each subcontractor under this act. The prime contractor shall list only one subcontractor for each portion as is defined by the prime contractor in his or her bid.

The bidder shall list all subcontractors (both DBE and non-DBE) in accordance with Title 49, Section 26.11 of the Code of Federal Regulations. This listing is required in addition to listing DBE Subcontractors elsewhere in the proposal.

Subcontractor's Name and Contract Name	Address and Telephone No.	Portion of Work and Percent of Total Bid
_____	_____	_____
_____	_____	_____
_____	_____	_____
_____	_____	_____

Subcontractor's Name and Contract Name	Address and Telephone No.	Portion of Work and Percent of Total Bid

**CONTRACTOR'S INDUSTRIAL
SAFETY RECORD**

Record Last Five (5) Full Years:

	Year of Record	2016	2017	2018	2019	2020	Total	Current Year
1. No. of contracts								
2. Total dollar amount of contracts (in thousands of \$)								
*3. No. of fatalities								
*4. No. of lost workday cases								
*5. No. of lost workday cases involving permanent transfer to another job or termination of employment								

The information required for these items is the same as required for Columns 3 to 6, Code 10, Occupational Injuries, Summary - Occupational Injuries and Illnesses No. 102.

The above information was compiled from the records that are available to me at this time and I declare under penalty of perjury that the information is true and accurate within the limitations of those records.

Name of Bidder (print)

Signature

Address

State Contractor's Lic.# & Classification

City

Zip Code

Telephone

BID BOND

(Bidders must use this form; use of any other bond form may render a bid non-responsive)

KNOW ALL PERSONS BY THESE PRESENTS that:

WHEREAS the _____

(A Public Agency), has issued an invitation for bids for the work described as follows: _____

San Pablo Avenue Pavement Rehabilitation

_____.

WHEREAS _____

(Name and address of Bidder)

(Principal), desires to submit a bid to Public Agency for the work.

WHEREAS, bidders are required under the provisions of the California Public Contract Code to furnish a form of bidder's security with their bid.

NOW, THEREFORE, we, the undersigned Principal, and _____

(Name and address of Surety)

(Surety) a duly admitted surety insurer under the laws of the State of California, as Surety, are held and firmly bound unto the Public Agency in the penal sum of _____

Dollars (\$ _____), being not less than ten percent (10%) of the total bid price, in lawful money of the United States of America, for the payment of which sum well and truly to be made, we bind ourselves, our heirs, executors, administrators, successors, and assigns, jointly and severally, firmly by these presents.

THE CONDITION OF THIS OBLIGATION IS SUCH THAT, if the hereby bounded Principal is awarded a contract for the work by the Public Agency and, within the time and in the manner required by the bidding specifications, enters into the written form of contract included with bidding specifications, furnishes the required bonds, one to guarantee faithful performance and the other to guarantee payment for labor and materials, and furnishes the required insurance coverages, then this obligation shall become null and void; otherwise, it shall be and remain in full force and effect.

In case suit is brought upon this bond, Surety further agrees to pay all court costs incurred by the Public Agency in the suit and reasonable attorneys' fees in an amount fixed by the court. Surety hereby waives the provisions of California Civil Code Section 2845.

IN WITNESS WHEREOF, this instrument has been duly executed by Principal and Surety, on the date set forth below, the name of each corporate party being hereto affixed and these presents duly signed by its undersigned representative(s) pursuant to authority of its governing body.

Dated: _____

Principal

Surety

By: _____
Its

By: _____
Its

By: _____
Its

By: _____
Its

(Seal)

(Seal)

Note: This bond must be dated, all signatures must be notarized, and evidence of the authority of any person signing as attorney-in-fact must be attached.

**NONCOLLUSION AFFIDAVIT
TO BE EXECUTED BY BIDDER AND SUBMITTED WITH BID**

[Title 23 United States Code Section 112 and Public Contract Code Section 7106]

State of California)
County of _____) ss.

In accordance with Title 23 United States Code Section 112 and Public Contract Code Section 7106

_____, being first duly sworn, deposes and says that he or she is _____

of _____
the party making the foregoing bid, that the bid is not made in the interest of, or on behalf of, any undisclosed person, partnership, company, association, organization, or corporation; that the bid is genuine and not collusive or sham; that the bidder has not directly or indirectly induced or solicited any other bidder to put in a false or sham bid, and has not directly or indirectly colluded, conspired, connived, or agreed with any bidder or anyone else to put in a sham bid, or that anyone shall refrain from bidding; that the bidder has not in any manner, directly or indirectly, sought by agreement, communication, or conference with anyone to fix the bid price of the bidder or any other bidder, or to fix any overhead, profit, or cost element of the bid price, or of that of any other bidder, or to secure any advantage against the public body awarding the contract of anyone interested in the proposed contract; that all statements contained in the bid are true; and, further, that the bidder has not, directly or indirectly, submitted his or her bid price or any breakdown thereof, or the contents thereof, or divulged information or data relative thereto, or paid, and will not pay, any fee to any corporation, partnership, company association, organization, bid depository, or to any member or agent thereof to effectuate a collusive or sham bid.

Signature _____

Subscribed and sworn to before me on _____
(Date)

(Notary Seal)

Signature _____
Notary Public

CITY OF PINOLE CHECKLIST FOR EXECUTION OF CONSTRUCTION CONTRACT

TO BE SUBMITTED BY SUCCESSFUL BIDDER:

- ___ Two Executed Notarized Copies of the Contract
- ___ Payment Bond in 100% of the Amount of Contract – one original
- ___ Performance Bond in 100% of the Amount of Contract – one original
- ___ General Liability Insurance Certificate in the Amount of \$1 Million, naming the City as an additional insured
- ___ Property Damage Insurance (\$1 Million minimum), naming the City as an additional insured
- ___ Automobile Insurance Certificate in the Amount of \$1 Million, naming the City as an additional insured
- ___ Workers Compensation Certificate (\$1,000,000 minimum)
- ___ Agreement to Comply with California Labor Law Requirements (C-10 Attached)
- ___ Indemnification and Hold Harmless Agreement (C-11 Attached)
- ___ Additional Insured Endorsement – Comprehensive (Commercial) General Liability (C-12 Attached)
- ___ Business License with the City of Pinole

Note: The above documents must remain valid during the life of the contract.

- ___ Exhibit 15-G Construction Contract DBE Commitment
- ___ Exhibit 15-H Proposer/Contractor Good Faith Efforts

INTENTIONALLY LEFT BLANK

CITY OF PINOLE

CONTRACT

For

San Pablo Avenue Rehabilitation

THIS AGREEMENT is made and entered this _____ day of _____, 2021, by and between the CITY OF PINOLE, hereinafter referred to as "City" and _____, hereinafter referred to as "Contractor."

WITNESSETH:

WHEREAS, Contractor and Contractor's Surety are providing the bonds attached hereto and incorporated by this reference, and

WHEREAS, City desires to contract with Contractor to perform the services detailed in this contract, including the Proposal, and

WHEREAS, Contractor has represented that it is fully qualified to assume and discharge such responsibility;

NOW, THEREFORE, the parties hereto do agree as follows:

1. Scope of Services. City hereby employs Contractor to perform the work and provide the services and materials for the project identified as: San Pablo Pavement Rehabilitation, Phase II, as described in these Plans and Specifications, attached hereto and incorporated herein by this reference, including miscellaneous appurtenant work. Such work shall be performed in a good and workmanlike manner, under the terms as stated herein and in these Plans and Specifications. In the event of any conflict between the terms of this agreement and any of the above-referenced documents, the terms of this agreement shall be controlling.
2. Compensation. In consideration of the services rendered hereunder, Contractor shall be paid _____ dollars in accordance with the prices as submitted on the Bid Sheet of the Proposal, attached hereto as a part of these Plans and Specifications and in accordance with the Special Provisions.
3. Independent Contractor. It is specifically understood and agreed by all parties hereto that Contractor is, for the purposes of this Agreement, an independent contractor and not an employee of the City. Accordingly, Contractor shall not be deemed the City's employee for any purpose whatsoever. Contractor shall not incur or have the power to incur any debt, obligation or liability whatever for or against City.
4. Assignment. This agreement may not be assigned by Contractor, in whole or in part, without the prior written consent of City.
5. Termination. This Agreement may be canceled by City at any time without penalty upon thirty (30) days' written notice. In the event of termination without fault of Contractor, City shall pay Contractor for all services rendered prior to date of termination, and such payment shall be in full satisfaction of all services rendered hereunder.

6. Worker's Compensation Insurance. California Labor Code Sections 1860 and 3700 provide that every contractor will be required to secure the payment of compensation to its employees. In accordance with the provisions of California Labor Code Section 1861, the Contractor hereby certifies as follows:

"I am aware of the provisions of Section 3700 of the Labor Code which require every employer to be insured against liability for worker's compensation or to under take self-insurance in accordance with the provisions of that code, and I will comply with such provisions before commencing the performance of the work of this contract."

7. Prevailing Wages and General Rate of Per Diem Wages. Pursuant to the Labor Code of the State of California, the Director of Industrial Relations has determined the general prevailing rate of wages and employer payments for health and welfare, vacation, pension and similar purposes applicable to the work to be done. This rate and scale are on file with the CITY ENGINEER and copies will be made available to any interested party on request. The Contractor to whom the contract is awarded, and the subcontractors under him must pay not less than these rates for this area to all workers employed in the execution of this contract.
8. Dispute resolution is subject to the provision of Article 1.5 (commencing at Section 20104) of Division 2, Part 3 of the California Public Contract Code regarding the resolution of public works claims of less than \$375,000. Article 1.5 mandates certain procedures for the filing of claims and supporting documentation by the contractor, for the response to such claims by the contracting public agency, for a mandatory meet and confer conference upon the request of the contractor, for mandatory non-binding mediation in the event of litigation is commenced, and for mandatory judicial arbitration upon the failure to resolve the dispute through mediation. This contract hereby incorporates the provisions of Article 1.5 as though fully set forth herein.
9. Suit; Recovery of Attorney Fees & Costs. Should either party bring any action to protect or enforce its rights hereunder, the prevailing party in such action shall be entitled to recover, in addition to all other relief, its reasonable attorney's fees and court costs.
10. Severability. If any term or provision or portion of a term or provision of this contract is declared invalid or unenforceable by any court of lawful jurisdiction, then the remaining terms and provisions or portions of terms or provisions will not be affected thereby and will remain in full force and effect.

IN WITNESS WHEREOF, the parties hereto have executed the within Agreement the day and year first above written.

CITY OF PINOLE

By: _____
City Manager

ATTEST:

By: _____
City Clerk

CONTRACTOR:

By: _____

Printed Name Date

Approved as to Form

City Attorney

CITY OF PINOLE

INSTRUCTIONS FOR EXECUTION OF INSTRUMENTS

THIS IS INSTRUCTION ONLY - IT IS NOT TO BE SIGNED OR USED IN CONJUNCTION WITH THE AGREEMENT OR ANY OTHER FORMS THAT MUST BE TURNED INTO THE CITY OF PINOLE - IT IS SIMPLY A FORMAT TO USE WHEN FILLING OUT DOCUMENTS.

1. By an Individual. The individual must sign the instrument, and if he/she is doing business under a fictitious name, the fictitious name must be set forth. The signature must be acknowledged before a Notary Public, using the proper form of acknowledgment.

2. By a Partnership. The name of the partnership must be set forth followed by the signatures of less than all of the partners will be acceptable only if submitted with evidence of authority to act on behalf of the partnership. The signatures must be acknowledged before a Notary Public, using the proper form of acknowledgment.

3. By a Corporation. The name of the corporation must be set forth, followed by the signatures of the President or Vice President and Secretary or Assistant Secretary. The signatures must be acknowledged before a Notary Public, using in substance the following form of acknowledgment.

4. By a Surety. The name of the surety must be set forth, followed by an authorized signature. The signatures must be acknowledged before a Notary Public, using the proper form of acknowledgment.

STATE OF _____)
) SS.
 COUNTY OF _____)

On _____, 20____, before me, the undersigned, appeared _____ known to me to be the President or Vice President and known to be to be the Secretary or Assistant Secretary of the corporation that executed the within instrument, and acknowledged to me that such corporation executed the within instrument pursuant to its by-laws or a resolution of its City Council.

WITNESS my signature and seal.

Notary Public

(Seal)

INSURANCE REQUIREMENTS FOR CITY OF PINOLE

Public Works Contract

The Contractor shall at all time during the term of this Agreement carry, maintain, and keep in full force and effect, with an insurance company admitted to do business in California and approved by the City (1) a policy or policies of broad-form comprehensive general liability insurance with minimum limits of \$1,000,000.00 combined single limit coverage against any injury, death, loss, or damage as a result of wrongful or negligent acts by the Contractor, its officers, employees, agents, and independent contractors in performance of services under this Agreement; (2) property damage insurance with a minimum limit of \$1,000,000.00; (3) automotive liability insurance with a minimum combined single limits coverage of \$1,000,000.00; and (4) worker's compensation insurance with a minimum limit of \$1,000,000.00 or the amount required by law, whichever is greater. The City, its officers, employees, attorneys, and volunteers shall be named as additional insureds on the policy(ies) as to comprehensive general liability and property damage.

1. All insurance policies shall provide that the insurance coverage shall not be non-renewed, canceled, reduced, or otherwise modified (except through addition of additional insureds to the policy) by the insurance carrier without the insurance carrier giving the City thirty (30) day's prior written notice thereof. The Contractor agrees that it will not cancel, reduce or otherwise modify said insurance coverage.
2. The Contractor agrees that if it does not keep the aforesaid insurance in full force and effect, and such insurance is available at a reasonable cost, the City may take out the necessary insurance and pay the premium thereon, and the repayment thereof shall be deemed an obligation of the Contractor and the cost of such insurance may be deducted, at the option of the City, from payments due the Contractor.
3. The Contractor shall submit to the City (1) insurance certificates indicating compliance with the minimum worker's compensation insurance requirements above, and (2) insurance policy endorsements above, not less than one (1) day prior to beginning of performance under this Agreement. Endorsements must be executed on the City's appropriate standard forms entitled "Additional Insured Endorsement," copies of which are attached hereto.

INTENTIONALLY LEFT BLANK

Bond No. _____

**PAYMENT BOND
(LABOR AND MATERIALS)**

KNOW ALL PERSONS BY THESE PRESENTS that:

WHEREAS the _____ (A
Public Agency), has awarded to _____

(Name and address of Contractor)

(Principal), a contract (the Contract) for the work described as follows:

San Pablo Avenue Pavement Rehabilitation

WHEREAS, Principal is required under the terms of the Contract and the California Civil Code to secure the payment of claims of laborers, mechanics, materialmen, and other persons as provided by law.

NOW, THEREFORE, we, the undersigned Principal, and _____

(Name and address of Surety)

(A Surety) a duly admitted surety insurer under the laws of the State of California, as Surety, are held and firmly bound unto the Public Agency in the penal sum of _____

_____ Dollars (\$ _____), this amount being not less than 100% of the total contract price, in lawful money of the United States of America, for the payment of which sum well and truly to be made, we bind ourselves, our heirs, executors, administrators, successors, and assigns, jointly and severally, firmly by these presents.

THE CONDITION OF THIS OBLIGATION IS SUCH THAT, if the hereby bounded Principal, his, her or its heirs, executors, administrators, successors or assigns, or subcontractors shall fail to pay any of the persons named in Section 3181 of the California Civil Code, or any amounts due under the Unemployment Insurance Code with respect to work or labor performed under the Contract, or for any amounts required to be deducted, withheld, and paid over to the Employment Development Department from the wages of employees of the Principal and subcontractors pursuant to Section 13020 of the Unemployment Insurance Code, with respect to work or labor performed under the Contract, the Surety will pay for the same in an amount not exceeding the penal sum specified in this bond; otherwise, this obligation shall become null and void.

This bond shall inure to the benefit of any of the persons named in Section 3181 of the California Civil Code so as to give a right of action to such persons or their assigns in any suit brought upon the bond. In case suit is brought upon this bond, Surety further agrees to pay all court costs and reasonable attorneys' fees in an amount fixed by the court.

Further, the Surety, for value received, hereby stipulates and agrees that no change, extension of time, alteration, addition or modification to the terms of the Contract, or of the work to be performed thereunder, or the specifications for the same, shall in any way affect its obligations under this bond, and it does hereby waive notice of any such change, extension of time, alteration, addition, or modification to the terms of the Contract or to the work or to the specifications thereunder. Surety hereby waives the provisions of California Civil Code sections 2845 and 2849.

IN WITNESS WHEREOF, two (2) identical counterparts of this instrument, each of which shall for all purposes be deemed an original hereof, have been duly executed by Principal and Surety, on the date set forth below, the name of each corporate party being hereto affixed and these presents duly signed by its undersigned representative(s) pursuant to authority of its governing body.

Dated: _____

Principal

Surety

By: _____
Its

By: _____
Its

By: _____
Its

By: _____
Its

(Seal)

APPROVED AS TO SURETY AND
PRINCIPAL AMOUNT

By: _____
Insurance Administrator

Note: This bond must be executed in duplicate and dated, all signatures must be notarized, and evidence of the authority of any person signing as attorney-in-fact must be attached.

Bond No. _____

PERFORMANCE BOND

KNOW ALL PERSONS BY THESE PRESENTS that:

WHEREAS the _____

(Public Agency), has awarded to _____

(Name and address of Contractor)

(Principal), a contract (the Contract) for the work described as follows:

San Pablo Avenue Pavement Rehabilitation

WHEREAS, Principal is required under the terms of the Contract to furnish a bond for the faithful performance of the Contract.

NOW, THEREFORE, we, the undersigned Principal, and _____

(Name and address of Surety)

(A Surety) a duly admitted surety insurer under the laws of the State of California, as Surety, are held and firmly bound unto the Public Agency in the penal sum of _____

Dollars (\$ _____), this amount being not less than the total contract price, in lawful money of the United States of America, for the payment of which sum well and truly to be made, we bind ourselves, our heirs, executors, administrators, successors, and assigns, jointly and severally, firmly by these presents.

THE CONDITION OF THIS OBLIGATION IS SUCH THAT, if the hereby bounded Principal, his, her or its heirs, executors, administrators, successors or assigns, shall in all things stand to and abide by, and well and truly keep and perform all the undertakings, terms, covenants, conditions and agreements in the Contract and any alteration thereof made as therein provided, on the Principal's part to be kept and performed, all within the time and in the manner therein specified, and in all respects according to their true intent and meaning, and shall indemnify and hold harmless the Public Agency, its officers, agents, and others as therein provided, then this obligation shall become null and void; otherwise, it shall be and remain in full force and effect.

In case suit is brought upon this bond, Surety further agrees to pay all court costs and reasonable attorneys' fees in an amount fixed by the court.

FURTHER, the Surety, for value received, hereby stipulates and agrees that no change, extension of time, alteration, addition or modification to the terms of the Contract, or of the work to be performed thereunder, or the specifications for the same, shall in any way affect its obligations under this bond, and it does hereby waive notice of any such change, extension of time, alteration, addition, or modification to the terms of the Contract or to the work or to the specifications thereunder. Surety hereby waives the provisions of California Civil Code 2845 and 2849. The City is the principal beneficiary of this bond and has all rights of a party hereto.

IN WITNESS WHEREOF, two (2) identical counterparts of this instrument, each of which shall for all purposes be deemed an original hereof, have been duly executed by Principal and Surety, on the date set forth below, the name of each corporate party being hereto affixed and these presents duly signed by its undersigned representative(s) pursuant to authority of its governing body.

Dated: _____

Principal

Surety

By: _____
Its

By: _____
Its

By: _____
Its

By: _____
Its

(Seal)

APPROVED AS TO SURETY AND
PRINCIPAL AMOUNT

By: _____
Insurance Administrator

Note: This bond must be executed in duplicate and dated, all signatures must be notarized, and evidence of the authority of any person signing as attorney-in-fact must be attached.

WORKER'S COMPENSATION CERTIFICATE OF INSURANCE

WHEREAS, the City of Pinole has required certain insurance to be provided by:

NOW THEREFORE, the undersigned insurance company does hereby certify that it has issued the policy or policies described below to the following named insureds and that the same are in force at this time:

1. This certificate is issued to:

City of Pinole
City Hall
2131 Pear Street
Pinole, California 90275

2. The insureds under such policy or policies are:

3. Worker's Compensation Policy or Policies in a form approved by the Insurance Commissioner of California covering all operations of the named insureds as follows:

<u>Policy Number</u>	<u>Effective Date</u>	<u>Expiration Date</u>
_____	_____	_____
_____	_____	_____
_____	_____	_____

4. Said policy or policies shall not be canceled, nor shall there be any reduction in coverage or limits of liability, unless and until thirty days' written notice thereof has been served upon the City Clerk of the City of Pinole

By: _____
Its Authorized Representative

INTENTIONALLY LEFT BLANK

**AGREEMENT TO COMPLY WITH
CALIFORNIA LABOR LAW REQUIREMENTS**

[Labor Code Sections 1720, 1773.9, 1773.11, 1775, 1776, 1777.5, 1813, 1860, 1861, 3700]

The undersigned Contractor certifies that it is aware of and hereby agrees to fully comply with the following provisions of California law:

1. Contractor acknowledges that this contract is subject to the provisions of Division 2, Part 7, Chapter 1 (commencing with Section 1720) of the California Labor Code relating to public works and the awarding public agency (Agency) and agrees to be bound by all the provisions thereof as though set forth in full herein.
2. Contractor agrees to comply with the provisions of California Labor Code Section 1773.9 which requires the payment of per diem wages to each worker needed to execute the work to the extent required by law, as well as California Labor Code Section 1773.11, which requires payment of holiday and overtime wages to each worker needed to execute the work to the extent required by law.
3. Contractor agrees to comply with the provisions of California Labor Code Sections 1774 and 1775 concerning the payment of prevailing rates of wages to workers and the penalties for failure to pay prevailing wages. The Contractor shall, as a penalty to the Agency, forfeit not more than fifty dollars (\$50) for each calendar day, or portion thereof, for each worker paid less than the prevailing rates as determined by the Director of Industrial Relations for the work or craft in which the worker is employed for any public work done under the contract by Contractor or by any subcontractor.
4. Contractor agrees to comply with the provisions of California Labor Code Section 1776 which require Contractor and each subcontractor to (1) keep accurate payroll records, (2) certify and make such payroll records available for inspection as provided by Section 1776, and (3) inform the Agency of the location of the records. The Contractor is responsible for compliance with Section 1776 by itself and all of its subcontractors.
5. Contractor agrees to comply with the provisions of California Labor Code Section 1777.5 concerning the employment of apprentices on public works projects, and further agrees that Contractor is responsible for compliance with Section 1777.5 by itself and all of its subcontractors.
6. Contractor agrees to comply with the provisions of California Labor Code Section 1813 concerning penalties for workers who work excess hours. The Contractor shall, as a penalty to the Agency, forfeit twenty-five dollars (\$25) for each worker employed in the execution of the contract by the Contractor or by any subcontractor for each calendar day during which such worker is required or permitted to work more than 8 hours in any one calendar day and 40 hours in any one calendar week in violation of the provisions of Division 2, Part 7, Chapter 1, Article 3 of the California Labor Code.
7. California Labor Code Sections 1860 and 3700 provide that every contractor will be required to secure the payment of compensation to its employees. In accordance with the provisions of California Labor Code Section 1861, Contractor hereby certifies as follows:

I am aware of the provisions of Section 3700 of the Labor Code, which require every employer to be insured against liability for worker's compensation or to undertake self-insurance in accordance with the provisions of that code, and I will comply with such provisions before commencing the performance of the work of this contract.

Date _____

Signature _____

**INDEMNIFICATION AND HOLD HARMLESS AGREEMENT
AND WAIVER OF SUBROGATION AND CONTRIBUTION**

Contract/Agreement/License/Permit No. or description: _____

Indemnitor(s) *(list all names)*:

To the fullest extent permitted by law, Indemnitor hereby agrees, at its sole cost and expense, to defend, protect, indemnify, and hold harmless the City of Pinole and its elected officials, officers, attorneys, agents, employees, volunteers, successors, and assigns (collectively Indemnitees) from and against any and all damages, costs, expenses, liabilities, claims, demands, causes of action, proceedings, expenses, judgments, penalties, liens, and losses of any nature whatsoever, including fees of accountants, attorneys, or other professionals and all costs associated therewith (collectively Liabilities), arising or claimed to arise, directly or indirectly, out of, in connection with, resulting from, or related to any act, failure to act, error, or omission of Indemnitor or any of its officers, agents, servants, employees, subcontractors, materialmen, suppliers or their officers, agents, servants or employees, arising or claimed to arise, directly or indirectly, out of, in connection with, resulting from, or related to the above-referenced contract, agreement, license, or permit (the Agreement) or the performance or failure to perform any term, provision, covenant, or condition of the Agreement, including this indemnity provision. This indemnity provision is effective regardless of any prior, concurrent, or subsequent active or passive negligence by Indemnitees and shall operate to fully indemnify Indemnitees against any such negligence. This indemnity provision shall survive the termination of the Agreement and is in addition to any other rights or remedies which Indemnitees may have under the law. Payment is not required as a condition precedent to an Indemnitee's right to recover under this indemnity provision, and an entry of judgment against an Indemnitee shall be conclusive in favor of the Indemnitee's right to recover under this indemnity provision. Indemnitor shall pay Indemnitees for any attorney's fees and costs incurred in enforcing this indemnification provision. Notwithstanding the foregoing, nothing in this instrument shall be construed to encompass (a) Indemnitees' sole negligence or willful misconduct to the limited extent that the underlying Agreement is subject to Civil Code 2782(a) or (b) the contracting public agency's active negligence to the limited extent that the underlying Agreement is subject to Civil Code 2782(b). This indemnity is effective without reference to the existence or applicability of any insurance coverages which may have been required under the Agreement or any additional insured endorsements which may extend to Indemnitees.

Notwithstanding the foregoing, to the extent that this Agreement includes design professional services under Civil Code Section 2782.8, as may be amended from time to time, such duties of Consultant to indemnify shall only be to the full extent permitted by Civil Code Section 2782.8.

Indemnitor, on behalf of itself and all parties claiming under or through it, hereby waives all rights of subrogation and contribution against the Indemnitees, while acting within the scope of their duties, from all claims, losses and liabilities arising out of or incident to activities or operations performed by or on behalf of the Indemnitor regardless of any prior, concurrent, or subsequent active or passive negligence by the Indemnitees.

In the event there is more than one person or entity named in the Agreement as an Indemnitor, then all obligations, liabilities, covenants and conditions under this instrument shall be joint and several.

Indemnitor

Name _____

Name _____

By: _____

By: _____

ADDITIONAL INSURED ENDORSEMENT COMPREHENSIVE GENERAL LIABILITY

Name and address of named insured (Named Insured):

Name and address of Insurance Company (Company):

General description of agreement(s), permit(s), license(s), and/or activity(ies) insured:

Notwithstanding any inconsistent statement in the policy to which this endorsement is attached (the Policy) or in any endorsement now or hereafter attached thereto, it is agreed as follows:

1. The _____ (Public Agency), its elected officials, officers, attorneys, agents, employees, and volunteers are additional insureds (the above named additional insureds are hereafter referred to as the "Additional Insureds") under the Policy in relation to those activities described generally above with regard to operations performed by or on behalf of the Named Insured. The Additional Insureds have no liability for the payment of any premiums or assessments under the Policy.
2. The insurance coverages afforded the Additional Insureds under the Policy shall be primary insurance, and no other insurance maintained by the Additional Insureds shall be called upon to contribute with the insurance coverages provided by the Policy.
3. Each insurance coverage under the Policy shall apply separately to each Additional Insured against whom claim is made or suit is brought except with respect to the limits of the Company's liability.
4. Nothing in this contract of insurance shall be construed to preclude coverage of a claim by one insured under the policy against another insured under the policy. All such claims shall covered as third-party claims, i.e., in the same manner as if separate policies had been issued to each insured. Nothing contained in this provision shall operate to increase or replicate the Company's limits of liability as provided under the policy.
5. The insurance afforded by the Policy for contractual liability insurance (subject to the terms, conditions and exclusions applicable to such insurance) includes liability assumed by the Named Insured under the indemnification and/or hold harmless provision(s) contained in or executed in conjunction with the written agreement(s) or permit(s) designated above, between the Named Insured and the Additional Insureds.
6. The policy to which this endorsement is attached shall not be subject to cancellation, change in coverage, reduction of limits (except as the result of the payment of claims), or non-renewal except after written notice to Public Agency, by certified mail, return receipt requested, not less than thirty (30) days prior to the effective date thereof. In the event of Company's failure to comply with this notice provision, the policy as initially drafted will continue in full force and effect until compliance with this notice requirement.
7. Company hereby waives all rights of subrogation and contribution against the Additional Insureds, while acting within the scope of their duties, from all claims, losses and liabilities arising out

of or incident to the perils insured against in relation to those activities described generally above with regard to operations performed by or on behalf of the Named Insured regardless of any prior, concurrent, or subsequent active or passive negligence by the Additional Insureds.

8. It is hereby agreed that the laws of the State of California shall apply to and govern the validity, construction, interpretation, and enforcement of this contract of insurance.

9. This endorsement and all notices given hereunder shall be sent to Public Agency at:

10. Except as stated above and not in conflict with this endorsement, nothing contained herein shall be held to waive, alter or extend any of the limits, agreements, or exclusions of the policy to which this endorsement is attached.

<u>TYPE OF COVERAGES TO WHICH THIS ENDORSEMENT ATTACHES</u>	<u>POLICY PERIOD FROM/TO</u>	<u>LIMITS OF LIABILITY</u>
---	------------------------------	----------------------------

11. Scheduled items or locations are to be identified on an attached sheet. The following inclusions relate to the above coverages. Includes:

Contractual Liability	Explosion Hazard
Owners/Landlords/Tenants	Collapse Hazard
Manufacturers/Contractors	Underground Property Damage
Products/Completed Operations	Pollution Liability
Broad Form Property Damage	Liquor Liability
Extended Bodily Injury	
Broad Form Comprehensive	
General Liability Endorsement	

12. A deductible or self-insured retention (*check one*) of \$ _____ applies to all coverage(s) except: _____ (*if none, so state*). The deductible is applicable per claim or per occurrence (*check one*).

13. This is an occurrence or G claims made policy (*check one*).

14. This endorsement is effective on _____ at 12:01 a.m. and forms a part of Policy Number _____.

I, _____ (*print name*), hereby declare under penalty of perjury under the laws of the State of California, that I have the authority to bind the Company to this endorsement and that by my execution hereof, I do so bind the Company.

Executed _____, 20 _____

Signature of Authorized Representative
(*Original signature only; no facsimile signature or initialed signature accepted*)

Telephone No.: (_____) _____

ADDITIONAL INSURED ENDORSEMENT AUTOMOBILE LIABILITY

Name and address of named insured (Named Insured):

Name and address of Insurance Company (Company):

General description of agreement(s), permit(s), license(s), and/or activity(ies) insured:

Notwithstanding any inconsistent statement in the policy to which this endorsement is attached (the Policy) or in any endorsement now or hereafter attached thereto, it is agreed as follows:

1. The _____ (Public Agency), its elected officials, officers, attorneys, agents, employees, and volunteers are additional insureds (the above named additional insureds are hereafter referred to as the Additional Insureds under the Policy in relation to those activities described generally above with regard to operations performed by or on behalf of the Named Insured. The Additional Insureds have no liability for the payment of any premiums or assessments under the Policy.
2. The insurance coverages afforded the Additional Insureds under the Policy shall be primary insurance, and no other insurance maintained by the Additional Insureds shall be called upon to contribute with the insurance coverages provided by the Policy.
3. Each insurance coverage under the Policy shall apply separately to each Additional Insured against whom claim is made or suit is brought except with respect to the limits of the Company's liability.
4. Nothing in this contract of insurance shall be construed to preclude coverage of a claim by one insured under the policy against another insured under the policy. All such claims shall covered as third-party claims, i.e., in the same manner as if separate policies had been issued to each insured. Nothing contained in this provision shall operate to increase or replicate the Company's limits of liability as provided under the policy.
5. The insurance afforded by the Policy for contractual liability insurance (subject to the terms, conditions and exclusions applicable to such insurance) includes liability assumed by the Named Insured under the indemnification and/or hold harmless provision(s) contained or executed in conjunction with the written agreement(s) or permit(s) designated above, between the Named Insured and the Additional Insureds.
6. The policy to which this endorsement is attached shall not be subject to cancellation, change in coverage, reduction of limits (except as the result of the payment of claims), or non-renewal except after written notice to Public Agency, by certified mail, return receipt requested, not less than thirty (30) days prior to the effective date thereto. In the event of Company's failure to comply with this notice provision, the policy as initially drafted will continue in full force and effect until compliance with this notice requirement.
7. Company hereby waives all rights of subrogation and contribution against the Additional Insureds, while acting within the scope of their duties, from all claims, losses and liabilities arising out

of or incident to the perils insured against in relation to those activities described generally above with regard to operations performed by or on behalf of the Named Insured regardless of any prior, concurrent, or subsequent active or passive negligence by the Additional Insureds.

8. It is hereby agreed that the laws of the State of California shall apply to and govern the validity, construction, interpretation, and enforcement of this contract of insurance.

9. This endorsement and all notices given hereunder shall be sent to Public Agency at:

CITY ENGINEER
City of Pinole
2131 Pear Street
Pinole, California 94564

10. Except as stated above and not in conflict with this endorsement, nothing contained herein shall be held to waive, alter or extend any of the limits, agreements, or exclusions of the policy to which this endorsement is attached.

TYPE OF COVERAGES TO WHICH OF <u>THIS ENDORSEMENT ATTACHES</u>	POLICY PERIOD <u>FROM/TO</u>	LIMITS <u>LIABILITY</u>
--	---------------------------------	----------------------------

11. Scheduled items or locations are to be identified on an attached sheet. The following inclusions relate to the above coverages. Includes:

Any Automobiles	Truckers Coverage
All Owned Automobiles	Motor Carrier Act
Non-owned Automobiles	Bus Regulatory Reform Act
Hired Automobiles	Public Livery Coverage
Scheduled Automobiles	
Garage Coverage	

12. A G deductible or G self-insured retention (*check one*) of \$ _____ applies to all coverage(s) except: ___ (*if none, so state*). The deductible is applicable G per claim or G per occurrence (*check one*).

13. This is a G occurrence or G claims made policy (*check one*).

14. This endorsement is effective on _____ at 12:01 a.m. and forms a part of Policy Number _____.

I, _____ (*print name*), hereby declare under penalty of perjury under the laws of the State of California, that I have the authority to bind the Company to this endorsement and that by my execution hereof, I do so bind the Company.

Executed _____, 20_____

Signature of Authorized Representative
*(Original signature only; no facsimile signature or
initialed signature accepted)*

Telephone No.: (____) _____

ADDITIONAL INSURED ENDORSEMENT EXCESS LIABILITY

Name and address of named insured (Named Insured):

Name and address of Insurance Company (Company):

General description of agreement(s), permit(s), license(s), and/or activity(ies) insured:

Notwithstanding any inconsistent statement in the policy to which this endorsement is attached (the Policy) or in any endorsement now or hereafter attached thereto, it is agreed as follows:

1. The _____ (A Public Agency), its elected officials, officers, attorneys, agents, employees, and volunteers are additional insureds (the above named additional insureds are hereafter referred to as the AAdditional Insureds) under the Policy in relation to those activities described generally above with regard to operations performed by or on behalf of the Named Insured. The Additional Insureds have no liability for the payment of any premiums or assessments under the Policy.
2. The insurance coverages afforded the Additional Insureds under the Policy shall be primary insurance, and no other insurance maintained by the Additional Insureds shall be called upon to contribute with the insurance coverages provided by the Policy.
3. Each insurance coverage under the Policy shall apply separately to each Additional Insured against whom claim is made or suit is brought, except with respect to the limits of the Company's liability.
4. Nothing in this contract of insurance shall be construed to preclude coverage of a claim by one insured under the policy against another insured under the policy. All such claims shall covered as third-party claims, i.e., in the same manner as if separate policies had been issued to each insured. Nothing contained in this provision shall operate to increase or replicate the Company's limits of liability as provided under the policy.
5. The insurance afforded by the Policy for contractual liability insurance (subject to the terms, conditions and exclusions applicable to such insurance) includes liability assumed by the Named Insured under the indemnification and/or hold harmless provision(s) contained in or executed in conjunction with the written agreement(s) or permit(s) designated above, between the Named Insured and the Additional Insureds.
6. The policy to which this endorsement is attached shall not be subject to cancellation, change in coverage, reduction of limits (except as the result of the payment of claims), or non-renewal except after written notice to Public Agency, by certified mail, return receipt requested, not less than thirty (30) days prior to the effective date thereto. In the event of Company's failure to comply with this notice provision, the policy as initially drafted will continue in full force and effect until compliance with this notice requirement.
7. Company hereby waives all rights of subrogation and contribution against the Additional Insureds, while acting within the scope of their duties, from all claims, losses and liabilities arising out of or incident to the perils insured against in relation to those activities described generally above with regard to operations performed by or on behalf of the Named Insured regardless of any prior, concurrent, or subsequent active or passive negligence by the Additional Insureds.
8. It is hereby agreed that the laws of the State of California shall apply to and govern the validity, construction, interpretation, and enforcement of this contract of insurance.

9. This endorsement and all notices given hereunder shall be sent to Public Agency at:

City Manager
City of Pinole
2131 Pear Street
Pinole, California 94564

10. Except as stated above and not in conflict with this endorsement, nothing contained herein shall be held to waive, alter or extend any of the limits, agreements, or exclusions of the policy to which this endorsement is attached.

<u>TYPE OF COVERAGES TO WHICH THIS ENDORSEMENT ATTACHES</u>	<u>POLICY PERIOD FROM/TO</u>	<u>LIMITS OF LIABILITY</u>
---	------------------------------	----------------------------

Following Form
Umbrella Liability

11. Applicable underlying coverages:

<u>INSURANCE COMPANY</u>	<u>POLICY NO.</u>	<u>AMOUNT</u>
--------------------------	-------------------	---------------

12. The following inclusions, exclusions, extensions or specific provisions relate to the above coverages:

13. A deductible or self-insured retention (*check one*) of \$ _____ applies to all coverage(s) except: _____ (*if none, so state*). The deductible is applicable G per claim or G per occurrence (*check one*).

14. This is an occurrence or claims made policy (*check one*).

15. This endorsement is effective on _____ at 12:01 a.m. and forms a part of Policy Number _____.

I, _____ (*print name*), hereby declare under penalty of perjury under the laws of the State of California, that I have the authority to bind the Company to this endorsement and that by my execution hereof, I do so bind the Company.

Executed _____, 20_____

Signature of Authorized Representative
(Original signature only; no facsimile signature or initialed signature accepted)

Telephone No.: (_____)

APPENDICES

APPENDIX I – GARBAGE PICK UP SCHEDULE

The trash and recycling pickup occurs on San Pablo Avenue between the western City limit and Pinole Shores Drive is as follows:

Solid waste pick-up is on Wednesdays

Recycling pick-up is on Fridays

The latest schedule is available at www.republicservices.com

APPENDIX II - PROJECT PLANS

SAN PABLO AVENUE REHABILITATION PROJECT

PROJECT No. R01801

CITY OF PINOLE

CONTRA COSTA COUNTY, CALIFORNIA

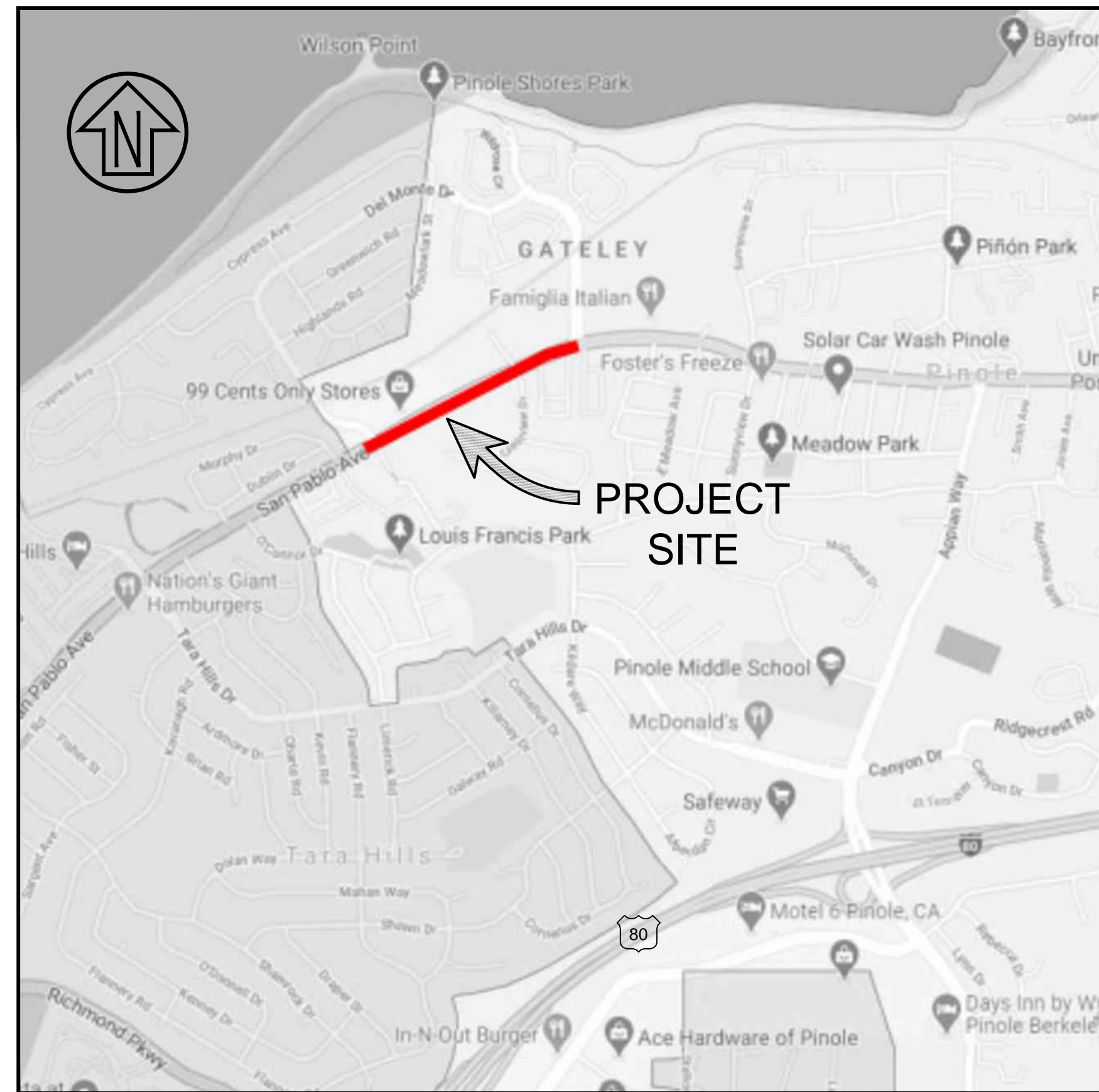

VICINITY MAP

SCALE: NTS

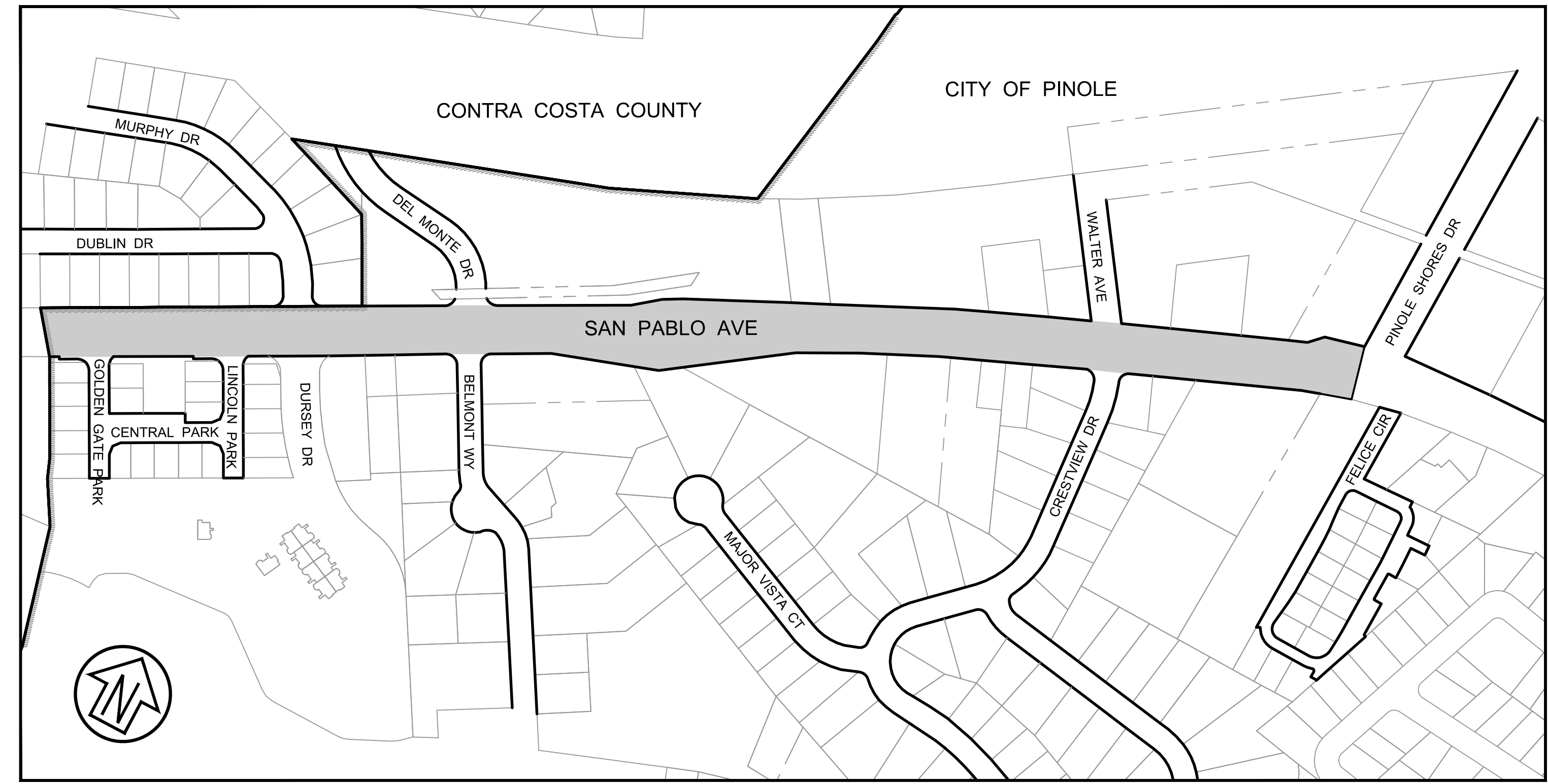

LOCATION MAP

SCALE: 1" = 200'

SHEET INDEX

C1.00	1	COVER SHEET
C1.01	2	ABBREVIATIONS, GENERAL NOTES & LEGEND (FUTURE SHEET)
C1.02	3	TYPICAL SECTION DETAILS
C2.00	4	STREET COMPOSITE PLAN (CITY LIMITS STA 1+00 TO DEL MONTE SHOPPING CENTER STA 14+00)
C2.01	5	STREET COMPOSITE PLAN (DEL MONTE SHOPPING CENTER STA 14+00 TO PINOLE SHORES DR STA 27+42)
C3.00	6	CURB RAMP ENLARGEMENT PLAN - GOLDEN GATE PARK & LINCOLN PARK (WEST) INTERSECTIONS
C3.01	7	CURB RAMP ENLARGEMENT PLAN - LINCOLN PARK (EAST) & DURSEY DR INTERSECTIONS
C3.02	8	CURB RAMP ENLARGEMENT PLAN - DEL MONTE DR & BELMONT WY INTERSECTIONS
C3.03	9	CURB RAMP ENLARGEMENT PLAN - MID-BLOCK CROSSING STA 17+07 TO STA 17+34
C3.04	10	CURB RAMP ENLARGEMENT PLAN - WALTER AVE INTERSECTION
C3.05	11	CURB RAMP ENLARGEMENT PLAN - CRESTVIEW DR INTERSECTION
C4.00	12	PAVEMENT SIGNING & STRIPING PLAN
C4.01	13	PAVEMENT SIGNING & STRIPING PLAN
C5.00	14	DETAIL SHEET

REVIEWED BY

Tamara Miller

TAMARA MILLER, CITY ENGINEER
PE 41813 EXP 03-31-2022

07/14/2021

DATE



Know what's below.
Call before you dig.

Rev	Date	Description	Designed	Drawn	Checked
-	07/14/21	BID SET	PW	RS	RS

CSW | ST2

CSW/Stuber-Stroeh Engineering Group, Inc.
Civil & Structural Engineers | Surveying & Mapping | Environmental Planning
Land Planning | Construction Management
45 Leveroni Court
Novato, CA 94949
tel: 415.883.9850
fax: 415.883.9835
http://www.cswst2.com

City: Pinole
County: Contra Costa
State: California

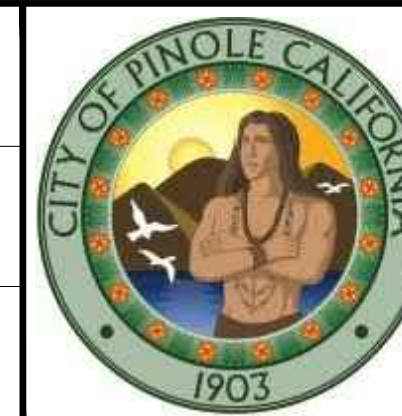

SAN PABLO AVE REHABILITATION

COVER SHEET

CITY OF PINOLE

Prepared Under the Direction of:



Sheet	C1.00
Scale:	As Shown
Date:	07/14/2021
Project #:	R01801
Sheet #:	1 of 14

I:\Projects\2021\07142021\07142021 - 08:19 PM - Pinole - 13.5602

ABBREVIATIONS

AB	AGGREGATE BASE
AC	ASPHALT CONCRETE
AD	AREA DRAIN
BVC	BEGIN VERTICAL CURVE
CB	CATCH BASIN
CJ	CONTROL JOINT
CL	CENTERLINE / CONTROL LINE
CP	CONTROL POINT
C&G	CURB AND GUTTER
DI	DROP INLET
DL	DAYLIGHT
DWY	DRIVEWAY
EG	EXISTING GRADE
EL	ELEVATION
EP	EDGE OF PAVEMENT
EX	EXISTING
FG	FINISH GRADE
FL	FLOWLINE
FS	FINISH SURFACE
GB	GRADE BREAK
HDPE	HIGH DENSITY POLYETHYLENE PIPE
HP	HIGH POINT
INV	INVERT
JP	JOINT POLE
LF	LINEAR FEET
LP	LOW POINT
MH	MAINTENANCE HOLE
NTS	NOT TO SCALE
O.C.	ON CENTER
P.C.C.	PORTLAND CEMENT CONCRETE
POC	POINT ON CURVE
PRO	PROPOSED
PVC	POLYVINYL CHLORIDE PIPE
RCP	REINFORCED CONCRETE PIPE
RW	RIGHT OF WAY
SD	STORM DRAIN
SDCO	STORM DRAIN CLEANOUT
SDMH	STORM DRAIN MANHOLE
SF	SQUARE FEET
SS	SANITARY SEWER
SSCO	SANITARY SEWER CLEANOUT
SSMH	SANITARY SEWER MANHOLE
SW	SIDEWALK
TC	TOP OF CURB
UCS	MARIN COUNTY UNIFORM CONSTRUCTION STANDARDS
UNO	UNLESS NOTED OTHERWISE
VIF	VERIFY IN FIELD

SYMBOLS

EXISTING	PROPOSED
	BOLLARD
	FLOW DIRECTION SIGN
	TREE / TREE TO BE REMOVED
	LIGHT - POST MOUNTED
	POWER POLE (WITH GUY)
	SANITARY SEWER - CLEANOUT
	STORM DRAINAGE - AREA DRAIN
	STORM DRAINAGE - CLEANOUT
	STORM DRAINAGE - DROP INLET
	FOUND / SET - CONTROL POINT
N/A	DETAIL NUMBER SHEET NUMBER

LINETYPES

EXISTING	PROPOSED
	CABLE TELEVISION
	CONTOUR - MAJOR
	CONTOUR - MINOR
	ELECTRICAL LINE
	FENCE
	FLOWLINE / SWALE
	GAS LINE
	RIGHT OF WAY
	RETAINING WALL
	SANITARY SEWER
	STORM DRAIN
	TOE OF BANK
	TOP OF BANK
	TREE DRIPLINE
	WATER

PRESERVATION OF SURVEY MONUMENTS

ALL CITY OF PINOLE (CITY) MONUMENTS LOCATED WITHIN THE PROJECT AREA SHALL BE REFERENCED PRIOR TO WORK COMMENCING BY A LICENSED LAND SURVEYOR AS REQUIRED BY SECTION 8771 OF THE BUSINESS AND PROFESSIONS CODE. CORNER RECORDS OF THIS WORK SHALL BE SUBMITTED FOR FILING TO BOTH THE COUNTY SURVEYOR OF MARIN COUNTY, AND THE CITY OF PINOLE PUBLIC WORKS DEPARTMENT.

THE CONTRACTOR SHALL BE RESPONSIBLE FOR THE PRESERVATION OF EXISTING SURVEY MONUMENTS, BENCHMARKS, REFERENCE MARKS AND STAKES. SHOULD ANY SURVEY MONUMENTS, BENCHMARKS, REFERENCE POINTS, OR STAKES BE DAMAGED OR DESTROYED DURING THE PERFORMANCE OF THIS WORK, THE CONTRACTOR SHALL REPLACE SAID ITEMS PER CITY CONSTRUCTION STANDARDS IN ACCORDANCE WITH THE SPECIAL PROVISIONS AND CONTACT THE CITY ENGINEER FOR FINAL INSPECTION AND ACCEPTANCE OF THE WORK.

CONSTRUCTION NOTES:

- SAWCUT EXISTING PAVEMENT AT LIMIT OF WORK, TYPICAL.
- PROTECT ALL DRAINAGE AND SEWAGE STRUCTURES AND PIPES FROM INFILTRATION OF ALL CONSTRUCTION DEBRIS FOR THE DURATION OF THE WORK.
- CURB RAMPS SHALL BE LOCATED AS SHOWN WITHIN THESE PLANS AND ADJUSTED IN THE FIELD BY THE ENGINEER, IF NECESSARY.

GENERAL NOTES:

- TRAFFIC INDEX = 8.0
- ALL MEASURED DISTANCES AND DIMENSIONS ARE SHOWN IN DECIMAL FEET THEREOF.
- UTILITIES AS SHOWN CONFORM TO AVAILABLE RECORD DATA. THE EXISTENCE, LOCATION AND CHARACTERISTICS OF UNDERGROUND UTILITY INFORMATION SHOWN ON THESE PLANS HAVE BEEN OBTAINED FROM A REVIEW OF AVAILABLE RECORD DATA. NO REPRESENTATION IS MADE AS TO THE ACCURACY OR COMPLETENESS OF SAID UTILITY INFORMATION. IT IS THE CONTRACTOR'S RESPONSIBILITY TO VERIFY LOCATION AND DEPTHS BY POT-HOLING OF ALL UTILITIES WITH APPROPRIATE AGENCIES, AND TO TAKE PRECAUTIONARY MEASURES TO PROTECT THE UTILITY LINES SHOWN AND ANY OTHER LINES NOT OF RECORD OR NOT SHOWN ON THESE PLANS. ANY CONFLICTS SHALL BE REPORTED IMMEDIATELY TO THE ENGINEER.
- THE CONTRACTOR IS RESPONSIBLE FOR MAINTAINING ADEQUATE DRAINAGE OF THE SITE, DURING INTERIM CONDITIONS OF CONSTRUCTION.
- CONTRACTOR SHALL PROVIDE ALL MATERIAL, LABOR, EQUIPMENT, FOR INSTALLATION, IMPLEMENTATION, AND MAINTENANCE OF ALL SURFACE WATER POLLUTION PREVENTION MEASURES THROUGHOUT THE FULL EXTENT OF THE PROJECT. SURFACE WATER IS CLASSIFIED AS ANY BODY OF WATER ABOVE GROUND.
- THE CONTRACTOR SHALL INVESTIGATE THE SITE AND BE AWARE OF LIMITED OVERHEAD CLEARANCES.
- ALL MAINTENANCE HOLES, CLEANOUTS AND WATER VALVES SHALL BE ADJUSTED TO GRADE WITHIN 48 HOURS OF PAVING. ALL PAVING SHALL BE COMPLETED WITHIN 24 HOURS OF RAISING THE UTILITY TO GRADE.
- REVOCALE ITEM - THE CONTRACTOR SHALL BE RESPONSIBLE FOR SETTING ALL UTILITY BOXES TO THE GRADE, INCLUDING COORDINATING WITH ALL UTILITY PROVIDERS.
- ALL STRIPING SHALL BE THERMOPLASTIC UNLESS OTHERWISE NOTED. IT SHALL BE THE CONTRACTOR'S RESPONSIBILITY TO MEASURE AND MARK EXISTING STRIPING, PAVEMENT MARKINGS, AND RAISED PAVEMENT MARKERS PRIOR TO AND DURING THE STREET WORK. LAYOUT MARKINGS SHALL BE LAID OUT IN ADVANCE OF FINAL STRIPING. ALL LAYOUT MARKINGS SHALL BE APPROVED IN WRITING BY THE ENGINEER. THE CONTRACTOR SHALL PROVIDE ONE WEEK TIME PERIOD FOR REVIEW OF LAYOUT MARKINGS. STRIPING CHANGES SHALL BE APPROVED BY THE CITY ENGINEER.
- PAVEMENT MARKINGS DISTURBED, DAMAGED IN ANY FORM, OR TO ANY DEGREE WHILE THE CONTRACTOR HAS CUSTODY OF THE SITE SHALL BE REPLACED IN THEIR ENTIRETY AT CONTRACTOR'S EXPENSE.
- CONTRACTOR SHALL CONTACT ENGINEER IN ADVANCE OF ANY DEMOLITION. CONTRACTOR SHALL ADHERE TO THE CITY'S SPECIFICATIONS AND RECOMMENDATIONS FOR TREE PRESERVATION.

BASIS OF TOPOGRAPHY

FIELD SURVEY PERFORMED AT ALL CURB RAMP IMPROVEMENT IN MARCH 2021. ROADWAY TOPOGRAPHIC INFORMATION IS BASED ON GPS SURVEY AND IS APPROXIMATE ONLY.

BENCHMARK

VERTICAL DATUM IS NGVD 88.

GEOTECHNICAL CORES

PAVEMENT RESTORATION RECOMMENDATIONS AND ASPHALT CONCRETE CORING CONDUCTED BY PAVEMENT ENGINEERING INC. AND SUMMARIZED IN THE REPORT ENTITLED "DEFLECTION ANALYSIS FOR THE CITY OF PINOLE PAVEMENT REHABILITATION PROJECT", DATED MARCH 16, 2021.

SURVEY CONTROL POINTS

POINT NO.	NORTHING	EASTING	ELEVATION	DESCRIPTION
1	2192420.7300	6037993.6200	49.38	CP CUT X
2	2193277.8099	6039574.7555	91.56	CP CUT X
3	2192571.0740	6038187.2251	57.10	CP CUT X
4	2192616.1607	6038460.9221	65.50	CP CUT X
5	2192807.6011	6038636.6696	70.96	CP CUT X
6	2192977.1467	6038933.1726	77.34	CP CUT X
7	2193112.8996	6039199.1881	83.68	CP CUT X
8	2193192.6735	6039373.3648	87.75	CP CUT X
9	2192298.725	6037864.291	42.07	CP CUT X

POLLUTION CONTROL NOTES:

- IF SIGNIFICANT SEDIMENT OR OTHER VISUAL SYMPTOMS OF IMPURITIES ARE NOTICED IN THE STORM WATER, CONTACT THE ENGINEER IMMEDIATELY.
- CONTRACTOR IS RESPONSIBLE FOR INSPECTION AND RESTORATION OF ALL ASPECTS OF THIS PLAN. SEDIMENT ON SIDEWALKS AND GUTTERS SHALL BE REMOVED BY SHOVEL AND/OR BROOM AND PLACED IN STOCKPILES.
- ALL DUMPSTERS OR OTHER TRASH STORAGE ENCLOSURES SHALL BE UTILIZED SOLELY FOR NON-HAZARDOUS MATERIALS.
- ALL EMPLOYEES, CONTRACTORS, AND SUBCONTRACTORS ARE RESPONSIBLE FOR CONFORMING TO THE ELEMENTS SHOWN ON THIS PLAN OR RELATED DOCUMENTS.
- THE CONTRACTOR IS RESPONSIBLE FOR OBTAINING ALL PERMITS AND FILING ALL PLANS WITH RELATED AGENCIES ASSOCIATED WITH THEIR WORK. THIS SHALL INCLUDE, BUT NOT BE LIMITED TO, PERMITS FOR STORAGE OF HAZARDOUS MATERIALS, BUSINESS PLANS, PERMITS FOR STORAGE OF FLAMMABLE LIQUIDS. ALL CONTRACTORS, OR SUBCONTRACTORS WORKING ON-SITE ARE INDIVIDUALLY RESPONSIBLE FOR OBTAINING AND SUBMITTING ANY BUSINESS PLANS OR PERMITS REQUIRED BY CITY, STATE OR LOCAL AGENCIES.
- CONTRACTOR SHALL LOCATE STORAGE, DELIVERY, OR WASH-OUT AREAS, TO SUIT THEIR OPERATIONS. CONTRACTOR TO MAINTAIN SECONDARY CONTAINMENT AS NECESSARY TO PROHIBIT POLLUTION AND TOXIC MATERIALS FROM ENTERING STORM DRAIN.
- CONTRACTOR SHALL UTILIZE SILT FILTERS DURING CONCRETE CONSTRUCTION NEAR EXISTING STORM DRAINAGE SYSTEM. AFTER COMPLETION OF THE SIDEWALK, DRIVEWAYS, CURB, GUTTER, AND PAVING, THE SILT FILTERS SHALL BE MODIFIED TO BURLAP SACKS FILLED WITH 3/4" DRAIN ROCK OR OTHER ACCEPTED BMP POSITIONED SURROUNDING EACH CATCH BASIN.

EROSION CONTROL NOTES:

- NO VEHICLES SHALL BE ALLOWED TO TRACK OR SPREAD SOIL FROM THE CONSTRUCTION AREAS ONTO EXISTING PAVED PUBLIC STREETS.
- THE EROSION AND SEDIMENT CONTROL MEASURES WILL BE OPERABLE DURING THE RAINY SEASON, OCTOBER 1ST TO APRIL 15TH. NO GRADING WILL OCCUR BETWEEN OCTOBER 1ST AND APRIL 15TH, UNLESS AUTHORIZED BY THE CITY.
- DURING THE RAINY SEASON, ALL PAVED AREAS WILL BE KEPT CLEAR OF EARTH MATERIAL AND DEBRIS. THE SITE WILL BE MAINTAINED SO THAT A MINIMUM OF SEDIMENT-LADEN RUNOFF ENTERS THE STORM DRAIN SYSTEM. THESE PLANS SHALL REMAIN IN EFFECT UNTIL THE IMPROVEMENTS ARE ACCEPTED BY THE TOWN, AND ALL SLOPES ARE STABILIZED FROM EROSION.

URBAN RUNOFF POLLUTION NOTES:

- STABILIZE ALL DENUDED AREAS AND MAINTAIN EROSION CONTROL MEASURES CONTINUOUSLY FOR THE DURATION OF THE PROJECT.
- REMOVE SPOILS PROMPTLY AND AVOID STOCKPILING OF FILL MATERIALS WHEN RAIN IS FORECAST. IF RAIN THREATENS, STOCK-PILED SOILS AND OTHER MATERIALS SHALL BE TARPED, AT THE REQUEST OF THE ENGINEER.
- STORE, HANDLE AND DISPOSE OF CONSTRUCTION MATERIALS AND WASTES SO AS TO PREVENT THEIR ENTRY TO THE STORM DRAIN SYSTEM. CONTRACTOR MUST NOT ALLOW CONCRETE, WASHWATERS, SLURRIES, PAINT OR OTHER MATERIALS TO ENTER CATCH BASINS OR TO ENTER SITE RUNOFF.
- USE FILTRATION OR OTHER MEASURES TO REMOVE SEDIMENT FROM DEWATERING EFFLUENT.
- NO CLEANING, FUELING OR MAINTAINING VEHICLES ON SITE SHALL BE PERMITTED IN ANY MANNER THAT ALLOWS DELETERIOUS MATERIALS TO ENTER CATCH BASINS OR TO ENTER SITE RUNOFF.
- CONTRACTOR TO RELOCATE CONCRETE WASHDOWN, VEHICLE STORAGE DELIVERY, AND NON HAZARDOUS WASTE AREAS AS NECESSARY TO FACILITATE THEIR OPERATION AND PROMOTE POLLUTION CONTROL.

BMP IMPLEMENTATION SCHEDULE:

- BMP'S APPROPRIATE FOR THE WORK BEING DONE SHALL BE IN PLACE AT ALL TIMES.
- PERIMETER CONTROL AND EXISTING INLET PROTECTION SHALL BE INSTALLED PRIOR TO ANY DEMOLITION.
- ALL OTHER BMP'S SHALL BE INSTALLED AT COMPLETION OF CONSTRUCTION OF EACH INLET.

PAVEMENT REHABILITATION RECOMMENDATIONS

STA 1+00 (CITY LIMIT) TO STA 5+20± (CHANGE OF PAVEMENT AT LINCOLN PARK)

HMA	MILL 5" / 2 1/2" HMA LEVELING COURSE / PAVEMENT FABRIC / 2 1/2" HMA SURFACE COURSE
DIG-OUT REPAIRS	11" DIGOUT OF BASE FAILURES

STA 5+20± (CHANGE OF PAVEMENT AT LINCOLN PARK) TO STA 27+42 (PINOLE SHORES DR)

HMA	MILL 2 1/2" / 1 1/2" HMA LEVELING COURSE / PAVEMENT FABRIC / 1 1/2" HMA SURFACE COURSE
DIG-OUT REPAIRS	4" DIGOUT OF BASE FAILURES

*RECOMMENDATIONS PER PAVEMENT ANALYSIS REPORT PREPARED BY PAVEMENT ENGINEERING INC. ON MARCH 16, 2021

CORING LOG

CORE No.	LOCATION	HMA LAYER (INCHES)	AB LAYER (INCHES)	R-VALUE
1	WB2 - 450' FROM PINOLE SHORES DR	6	20-1/2	-
2	WB1 - 860' FROM PINOLE SHORES DR	7	22	-
3	WB2 - 1,320' FROM PINOLE SHORES DR	7	20	-
4	WB1 - 1,625' FROM PINOLE SHORES DR	6-1/2	22-1/2	-
5	WB2 - 2,100' FROM PINOLE SHORES DR	9-1/2	17	-
6	WB1 - 2,425' FROM PINOLE SHORES DR	16-1/2	1	12
7	EB1 - 360' FROM WEST CITY LIMIT	16	10	-
8	EB1 - 750' FROM WEST CITY LIMIT	8	20	-
9	EB1 - 1,370' FROM WEST CITY LIMIT	6-1/2	18	28
10	EB1 - 1,840' FROM WEST CITY LIMIT	6	17	-
11	EB1 - 2,220' FROM WEST CITY LIMIT	6-1/4	21-1/2	-
12	EB1 - 2,550' FROM WEST CITY LIMIT	7-1/2	19-1/2	-

Rev	Date	Description	Designed	Drawn	Checked
-	07/14/21	BID SET	PW	RS	RS

CSW ST 2
CSW/Stuber-Stroeh Engineering Group, Inc.
 Civil & Structural Engineers Surveying & Mapping | Environmental Planning
 Land Planning | Construction Management
 45 Leveroni Court Novato, CA 94949
 tel: 415.883.9850 fax: 415.883.9835
 http://www.cswst2.com

City	Pinole
County	Contra Costa
State	California



SAN PABLO AVE REHABILITATION
 ABBREVIATIONS, GENERAL NOTES,
 AND LEGEND
 CITY OF PINOLE

Prepared Under the Direction of:

 RICHARD J. SOUZA
 No. 67892
 CIVIL
 STATE OF CALIFORNIA

Sheet	C1.01
Scale:	As Shown
Date:	07/14/2021
Project #:	R01801
Sheet #:	2 of 14

I:\Projects\2021\20210713\2021-06-19\PM_Planck_11

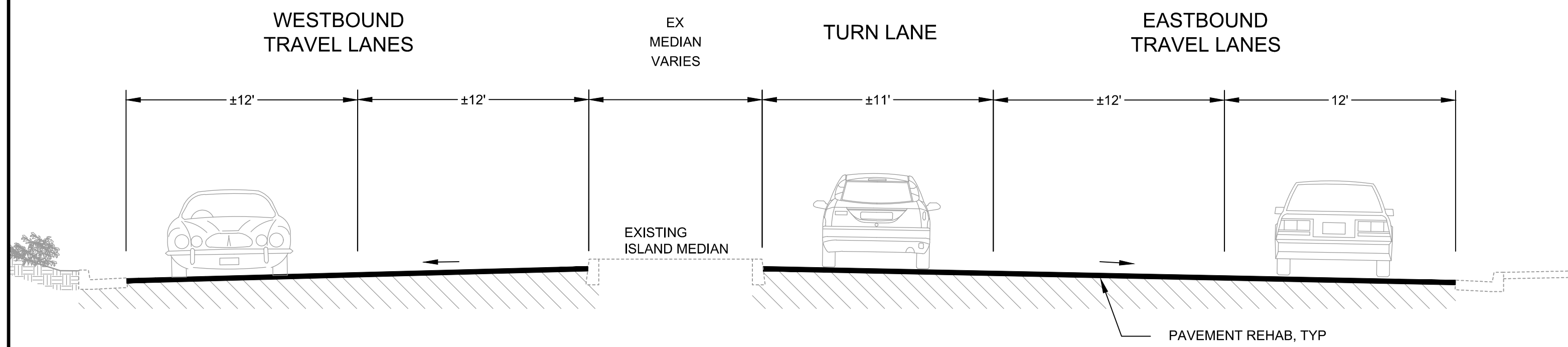

A TYPICAL SECTION DETAIL (STATION 4+50 TO 5+50)
SCALE: 1" = 10'

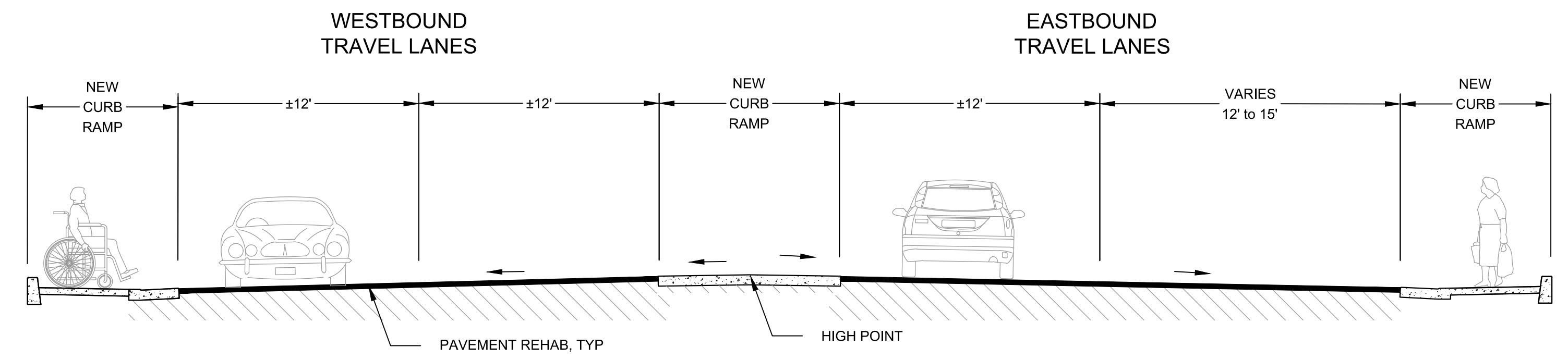

C MID-BLOCK CROSSING SECTION DETAIL (STATION 17+15)
SCALE: 1" = 10'

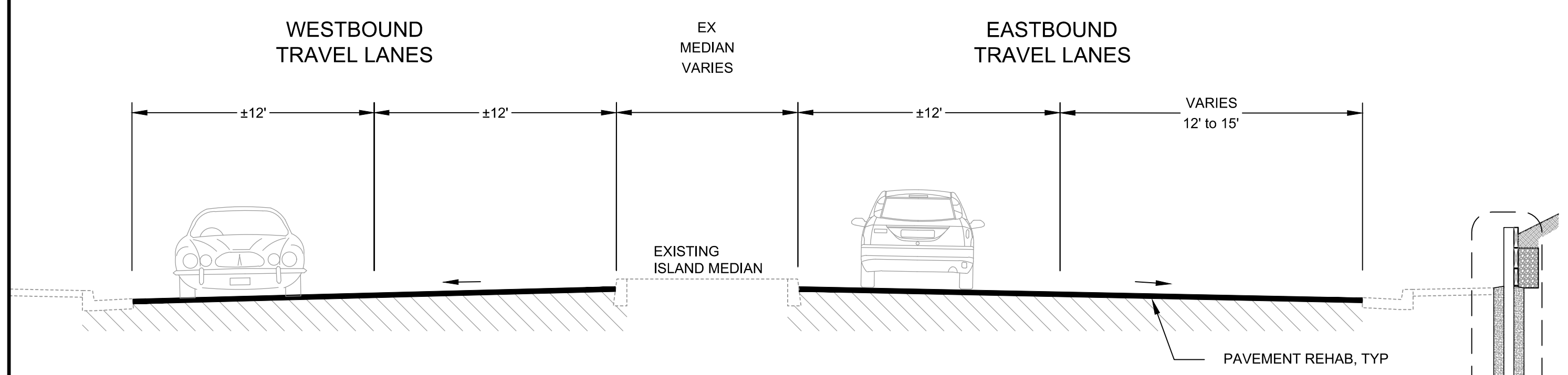

B TYPICAL SECTION DETAIL (STA 11+50 TO 15+50)
SCALE: 1" = 10'

NEW RETAINING WALL
PER DETAIL 6, SHEET C5.00

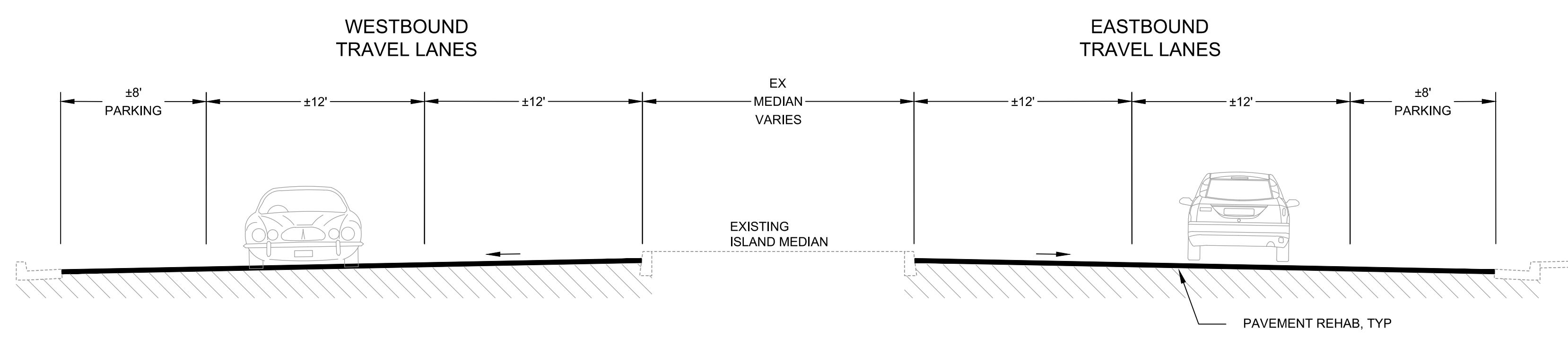

D TYPICAL SECTION DETAIL (STA 24+00 TO 26+25)
SCALE: 1" = 10'

Rev	Date	Description	Designed	Drawn	Checked
-	07/14/21	BID SET	PW	RS	RS

CSW | ST2
CSW/Stuber-Stroeh Engineering Group, Inc.
 Civil & Structural Engineers | Surveying & Mapping | Environmental Planning
 Land Planning | Construction Management
 45 Leveroni Court | tel: 415.883.9850
 Novato, CA 94949 | fax: 415.883.9835
<http://www.cswst2.com> | ©2021

City Pinole
 County Contra Costa
 State California



SAN PABLO AVE REHABILITATION
TYPICAL SECTION DETAILS
 CITY OF PINOLE

Prepared Under the Direction of:

 RICHARD J. SOUZA
 No. 67892
 CIVIL
 STATE OF CALIFORNIA

Sheet **C1.02**

Scale:	As Shown
Date:	07/14/2021
Project #:	R01801
Sheet #:	3 of 14

View: 07/14/2021 10:00:00 AM Project: 20210714 SAN PABLO AVE REHABILITATION\DWG\Sheet\C1.02 - TYP SECTION DETAILS.dwg 07/14/2021 10:00:00 AM 11

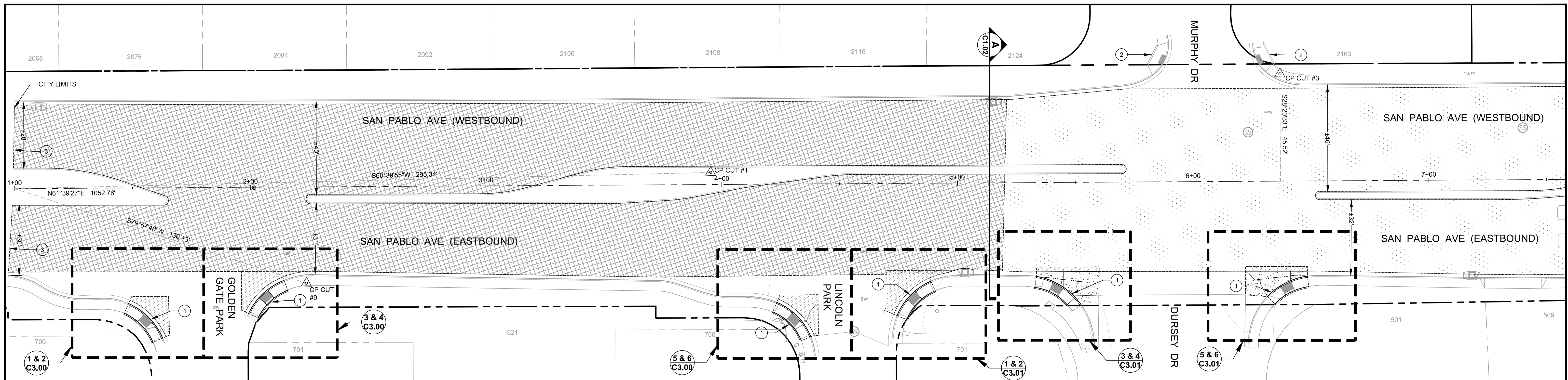

PLAN VIEW (CITY LIMITS - DURSEY/MURPHY)
SCALE: 1" = 20'

LEGEND

- MILL 2 1/2" / 1/2" HMA LEVELING COURSE / PAVEMENT FABRIC / 1 1/2" HMA SURFACE COURSE
- MILL 5" / 2 1/2" HMA LEVELING COURSE / PAVEMENT FABRIC / 2 1/2" HMA SURFACE COURSE
- RED CURB PAINT
- EXISTING PARKING AREA
- NEW TRUNCATED DOMES

KEYNOTES

- 1 NEW CASE C RAMP PER CALTRANS STD PLAN A88A
- 2 EXISTING CURB RAMP TO REMAIN
- 3 EXISTING ASPHALT TRANSITION
- 4 EXISTING PED PUSH BUTTON
- 5 PRESSURE TREATED WOOD RETAINING WALL (1' - 3' HEIGHT) SEE DETAIL 6, SHEET C5.0
- 6 REPLACE LOOP DETECTOR

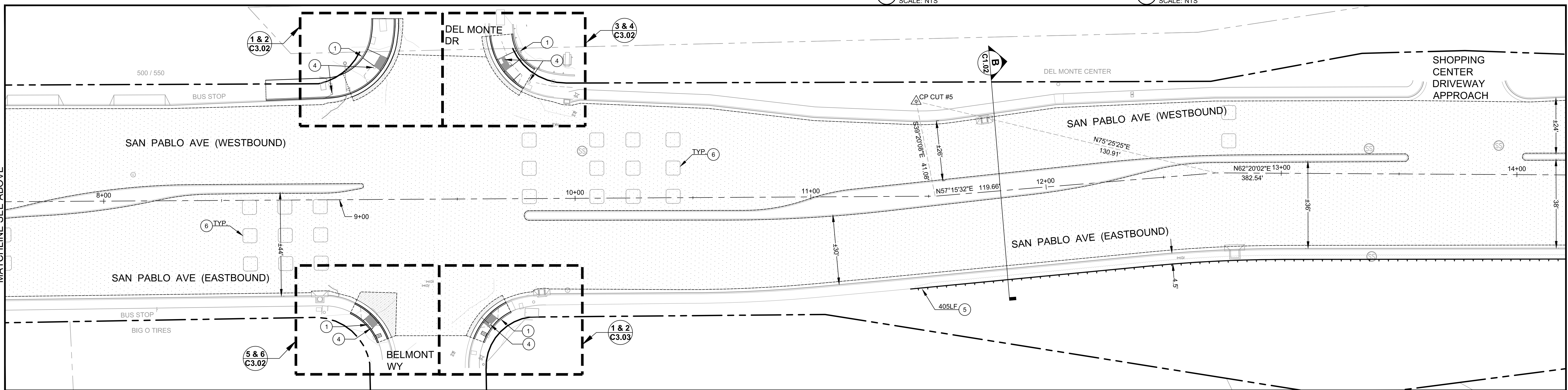
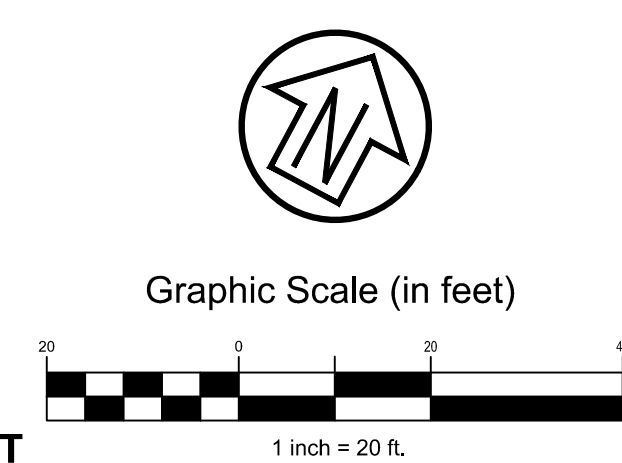
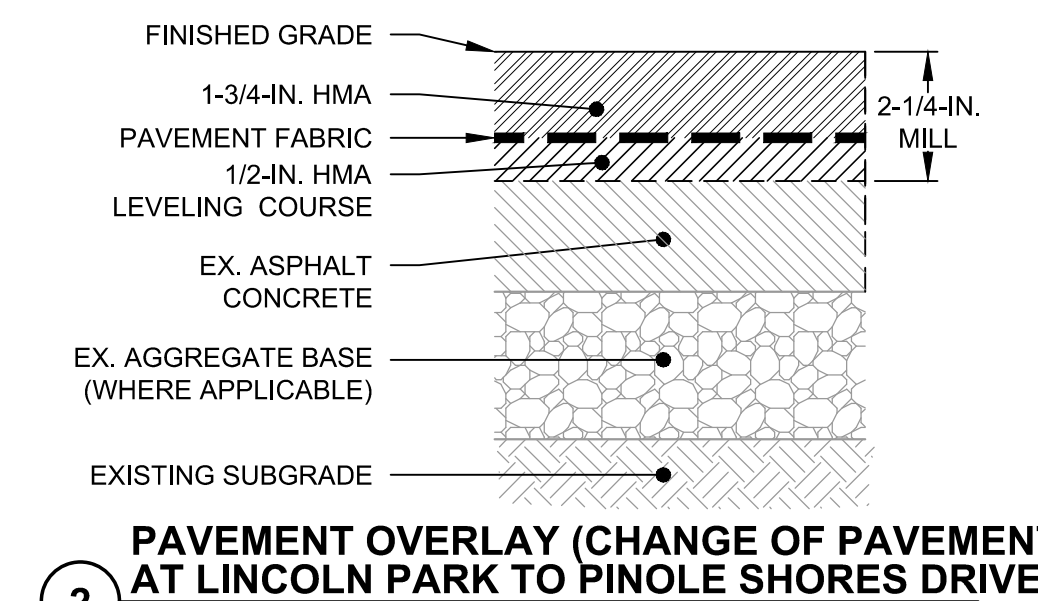
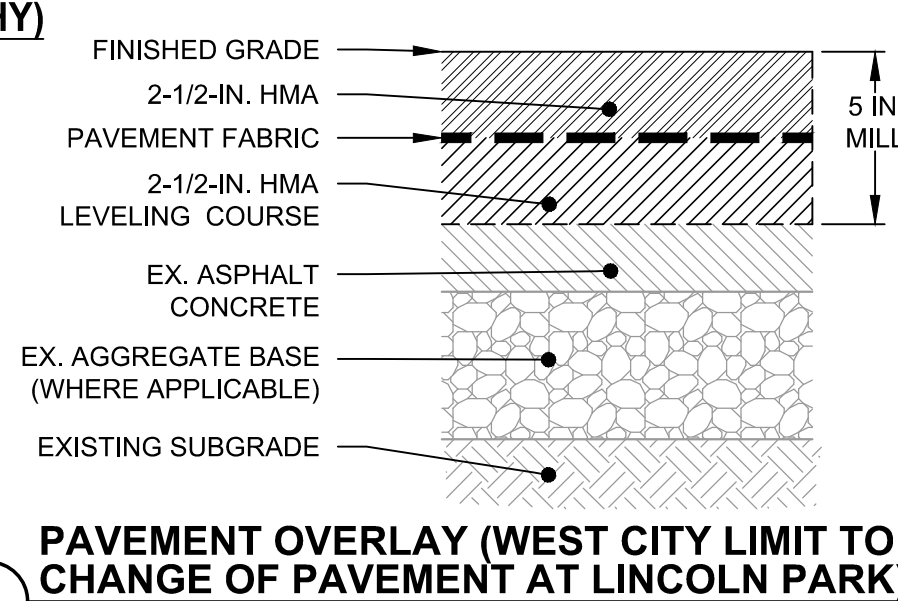

PLAN VIEW (BELMONT - DEL MONTE CENTER)
SCALE: 1" = 20'

Rev	Date	Description	Designed	Drawn	Checked
-	07/14/21	BID SET	PW	RS	RS

CSW ST2
CSW/Stuber-Stroeh Engineering Group, Inc.
 Civil & Structural Engineers | Surveying & Mapping | Environmental Planning
 Land Planning | Construction Management
 45 Leveroni Court | Novato, CA 94949 | tel: 415.883.9850 | fax: 415.883.9835
<http://www.cswst2.com> | 2021

City	Pinole
County	Contra Costa
State	California



SAN PABLO AVE REHABILITATION
PAVING PLAN
STATION 1+00 TO 14+15
CITY OF PINOLE

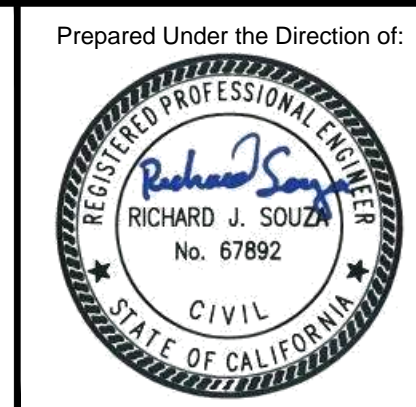

Sheet	C2.00
Scale:	1" = 20'
Date:	07/14/2021
Project #:	R01801
Sheet #:	4 of 14

MATCHLINE SEE BELOW / MATCHLINE SEE ABOVE / MATCHLINE SEE SHEET C2.01

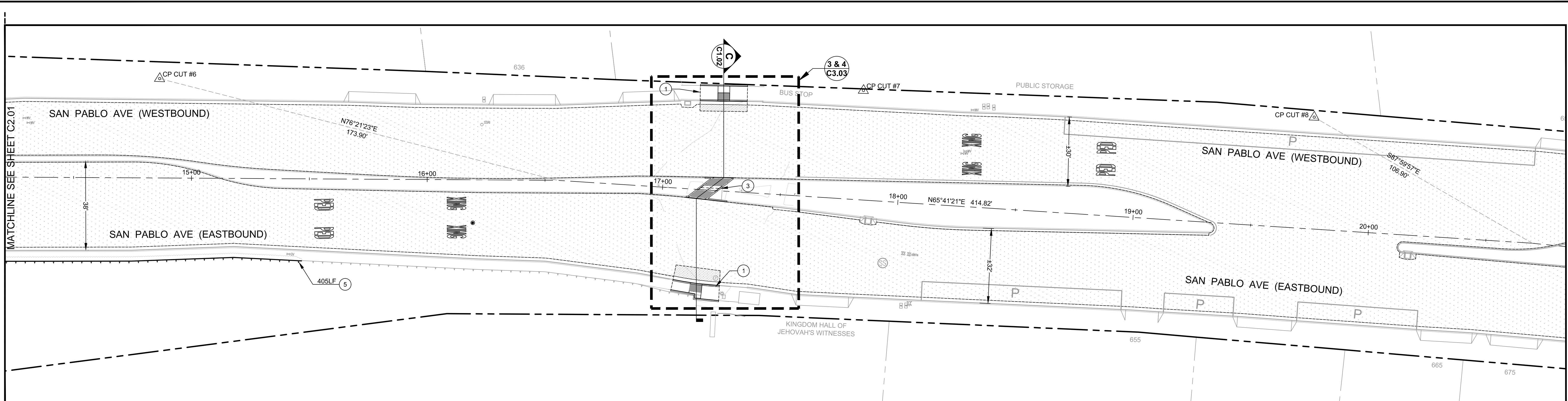

LEGEND

- MILL 5" / 2 1/2" HMA LEVELING COURSE / PAVEMENT FABRIC / 2 1/2" HMA SURFACE COURSE
- P EXISTING PARKING AREA
- NEW TRUNCATED DOMES

KEYNOTES

- 1 NEW CASE C RAMP PER CALTRANS STD PLAN A88A
- 2 EXISTING CURB RAMP TO REMAIN
- 3 EXISTING ASPHALT TRANSITION
- 5 PRESSURE TREATED WOOD RETAINING WALL (1' - 3' HEIGHT) SEE DETAIL 6, SHEET C5.0
- 6 REPLACE LOOP DETECTOR

PLAN VIEW (DELMONTE CENTER TO WALTERS)

SCALE: 1" = 20'

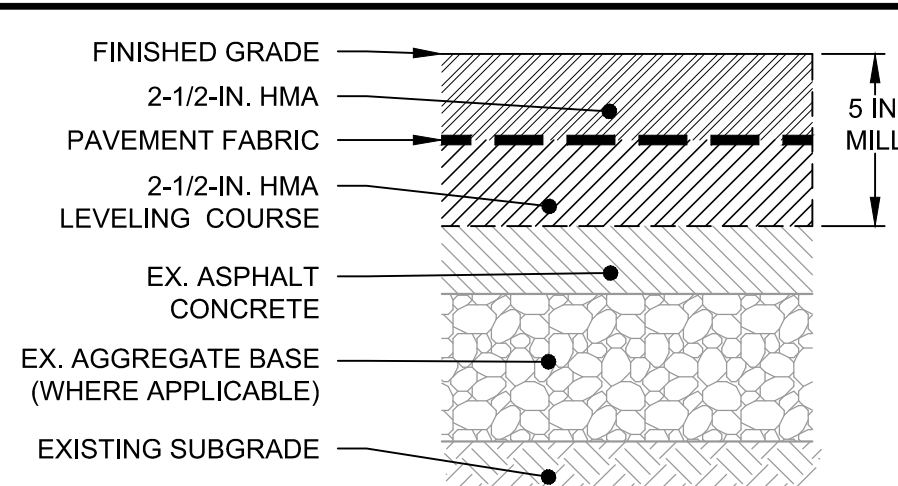

1 PAVEMENT OVERLAY (WEST CITY LIMIT TO CHANGE OF PAVEMENT AT LINCOLN PARK)
SCALE: NTS

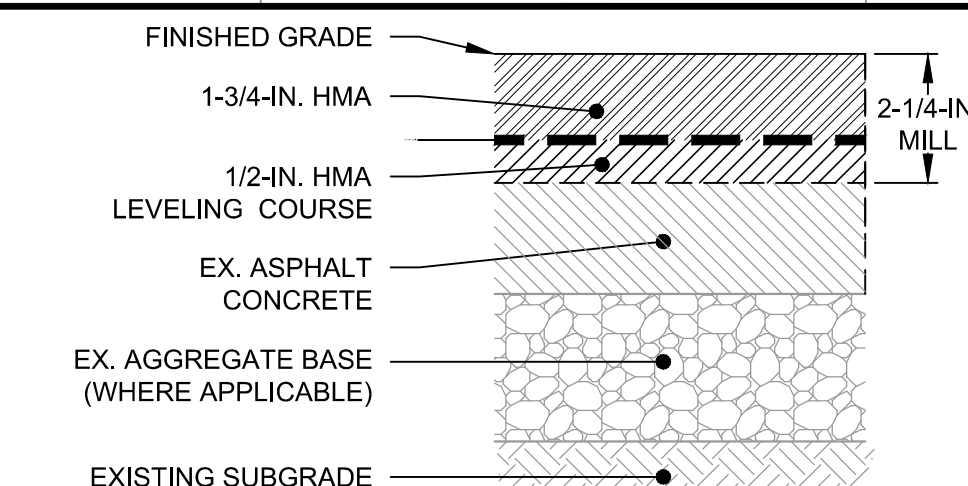

2 PAVEMENT OVERLAY (CHANGE OF PAVEMENT AT LINCOLN PARK TO PINOLE SHORES DRIVE)
SCALE: NTS

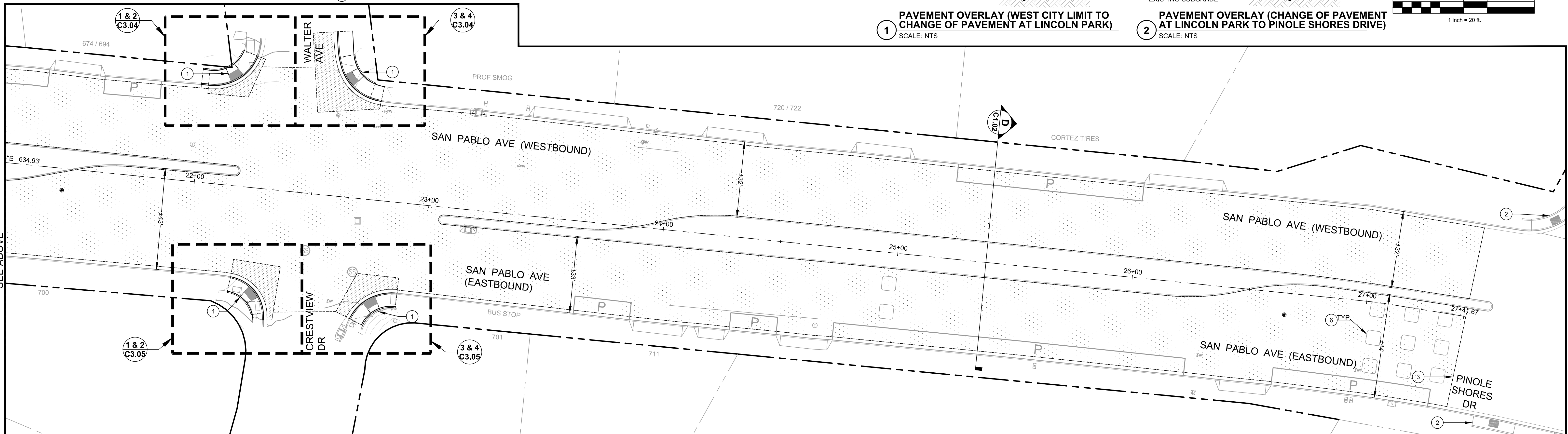
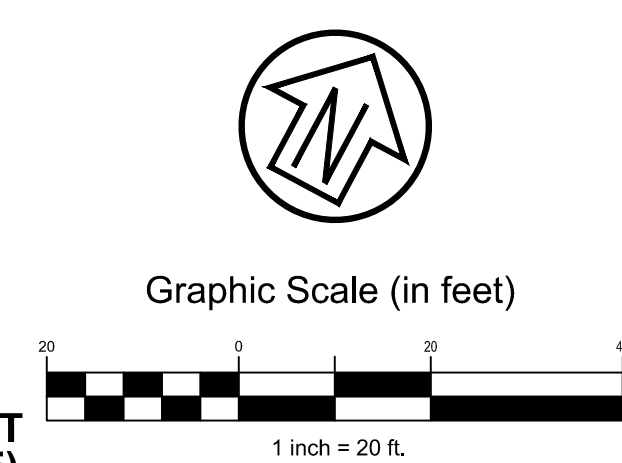

PLAN VIEW (WALTERS/CRESTVIEW - PINOLE SHORES)

SCALE: 1" = 20'

Rev	Date	Description	Designed	Drawn	Checked
-	07/14/21	BID SET	PW	RS	RS

CSW ST2
CSW/Stuber-Stroeh Engineering Group, Inc.
 Civil & Structural Engineers | Surveying & Mapping | Environmental Planning
 Land Planning | Construction Management
 45 Leveroni Court | Novato, CA 94949 | tel: 415.883.9850 | fax: 415.883.9835
<http://www.cswst2.com> | 2021

City Pinole
 County Contra Costa
 State California



SAN PABLO AVE REHABILITATION
PAVING PLAN
STATION 14+15 TO 27+42
CITY OF PINOLE

Prepared Under the Direction of:

 RICHARD J. SOUZA
 No. 67892
 CIVIL
 STATE OF CALIFORNIA

Sheet **C2.01**

Scale:	1" = 20'
Date:	07/14/2021
Project #:	R01801
Sheet #:	5 of 14

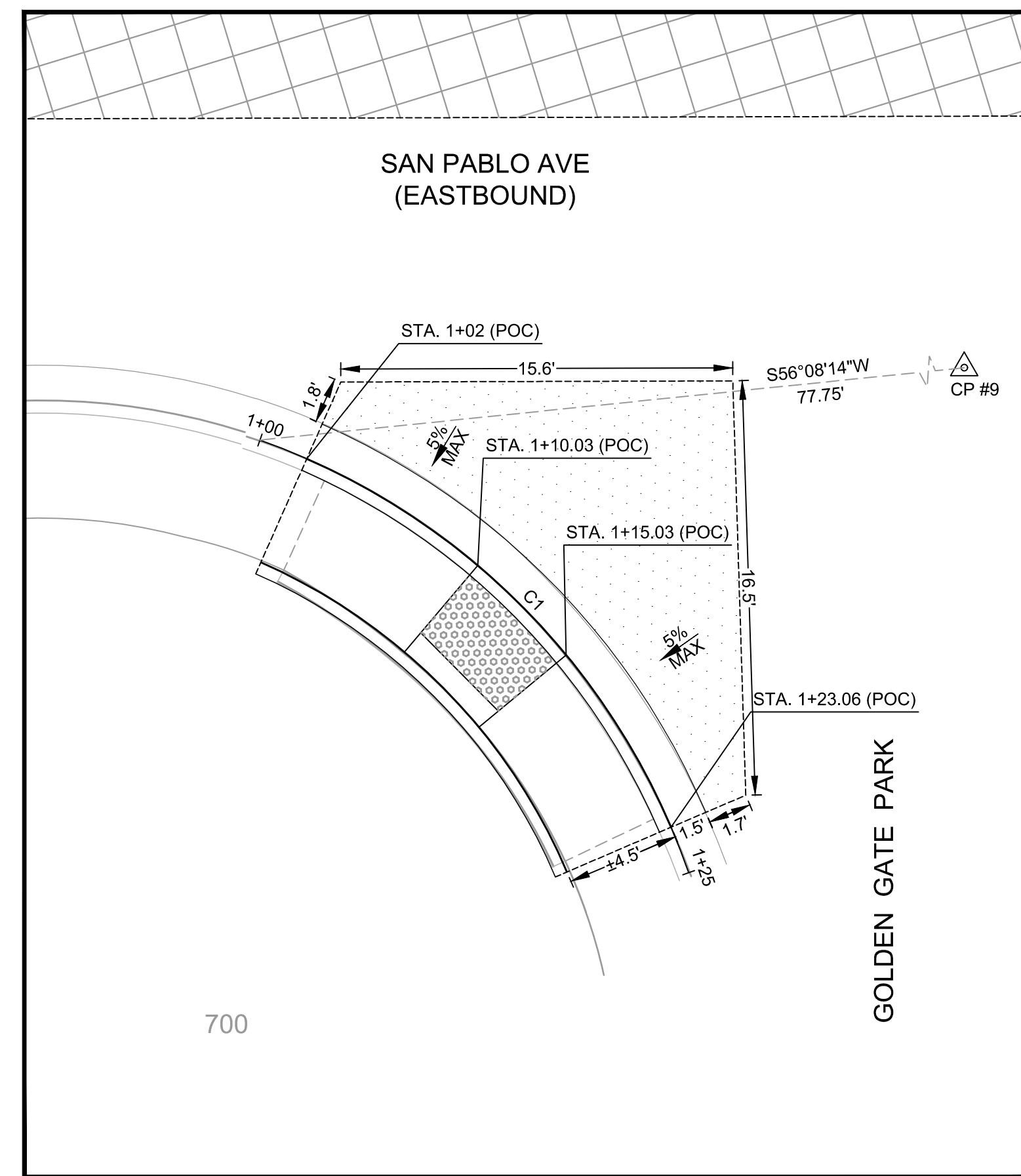

1 HORIZONTAL CONTROL - SW GOLDEN GATE PARK CURB RAMP
SCALE: 1" = 5'

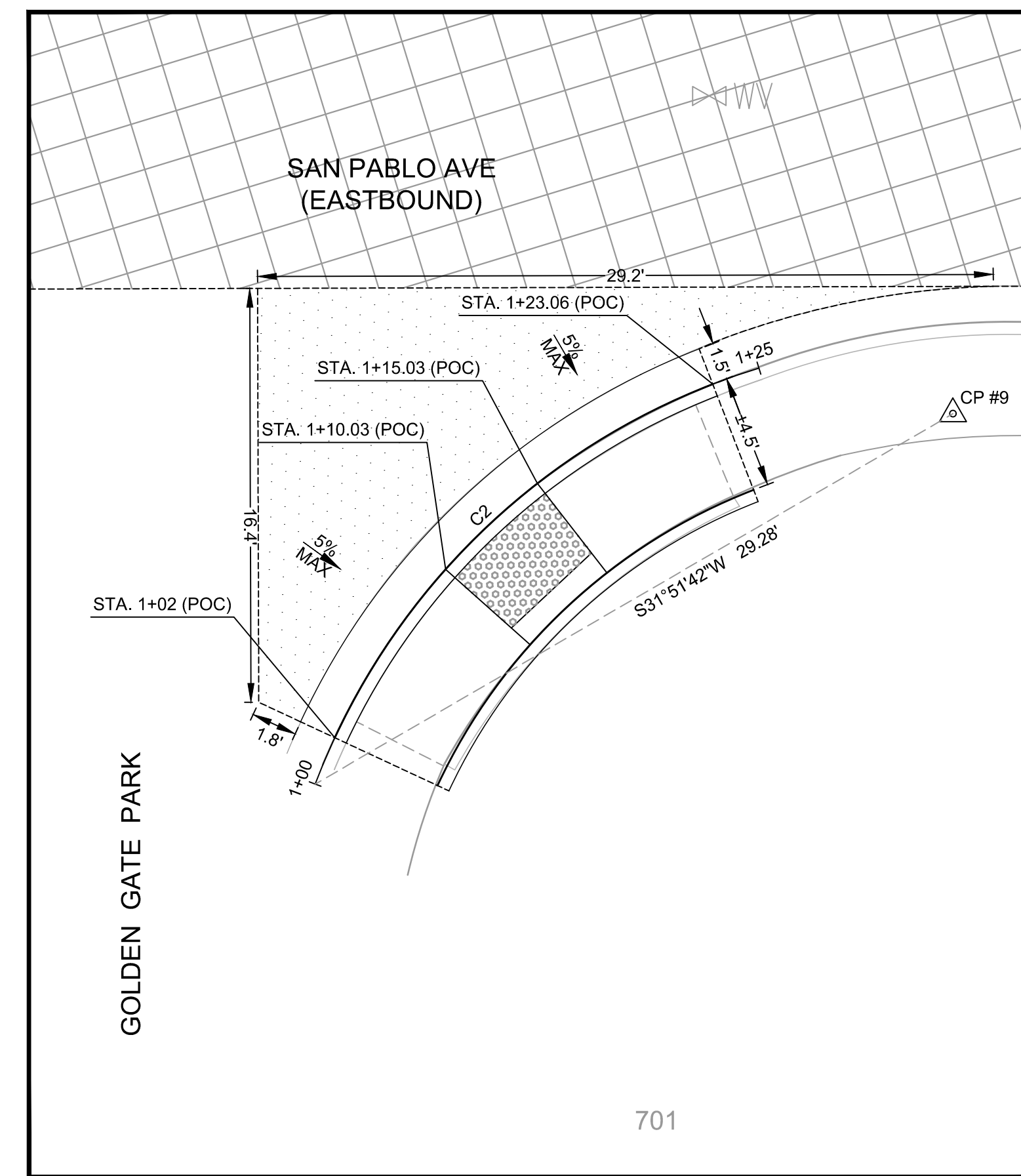

3 HORIZONTAL CONTROL - SE GOLDEN GATE PARK CURB RAMP
SCALE: 1" = 5'

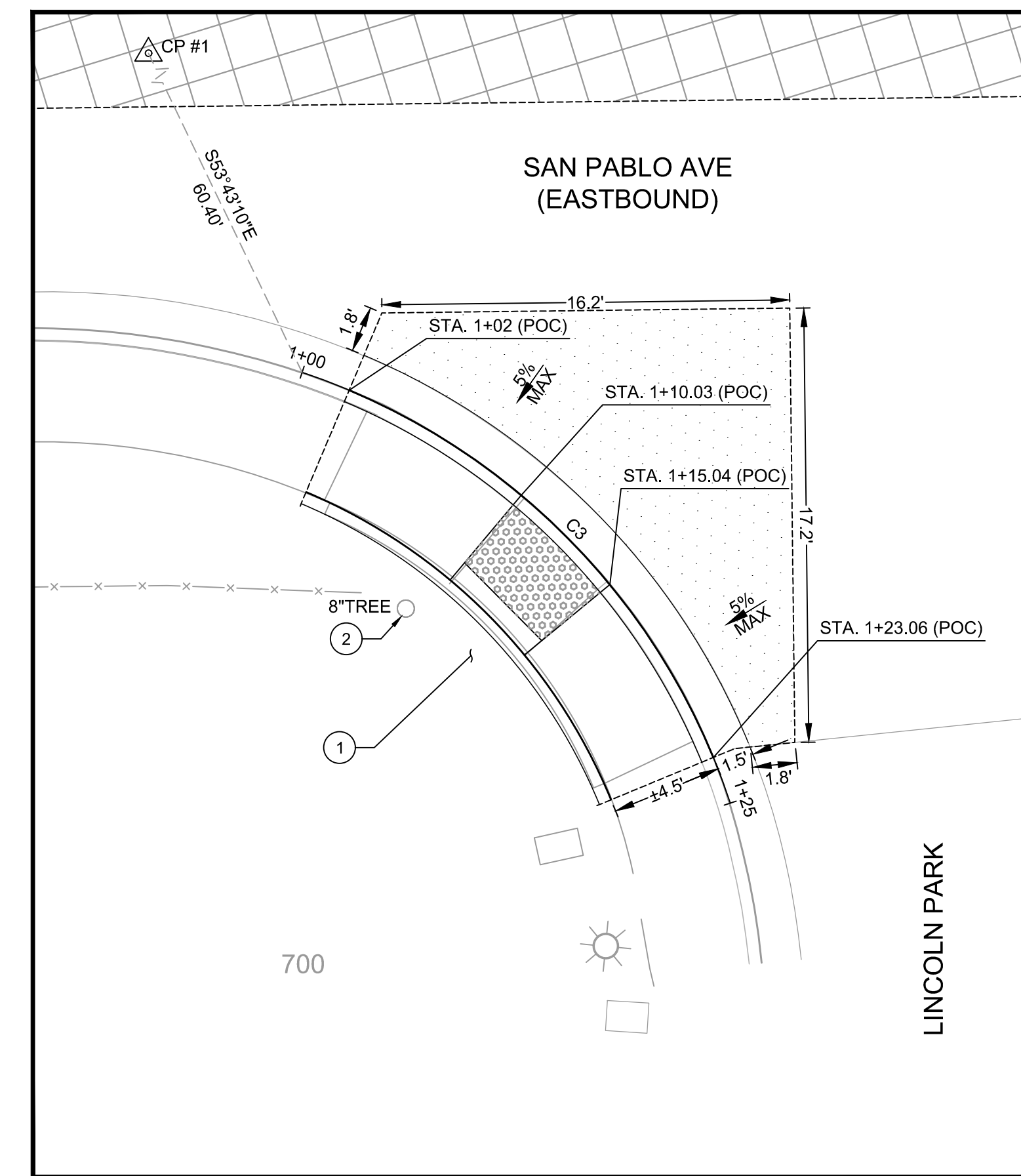

5 HORIZONTAL CONTROL - SW LINCOLN PARK CURB RAMP
SCALE: 1" = 5'

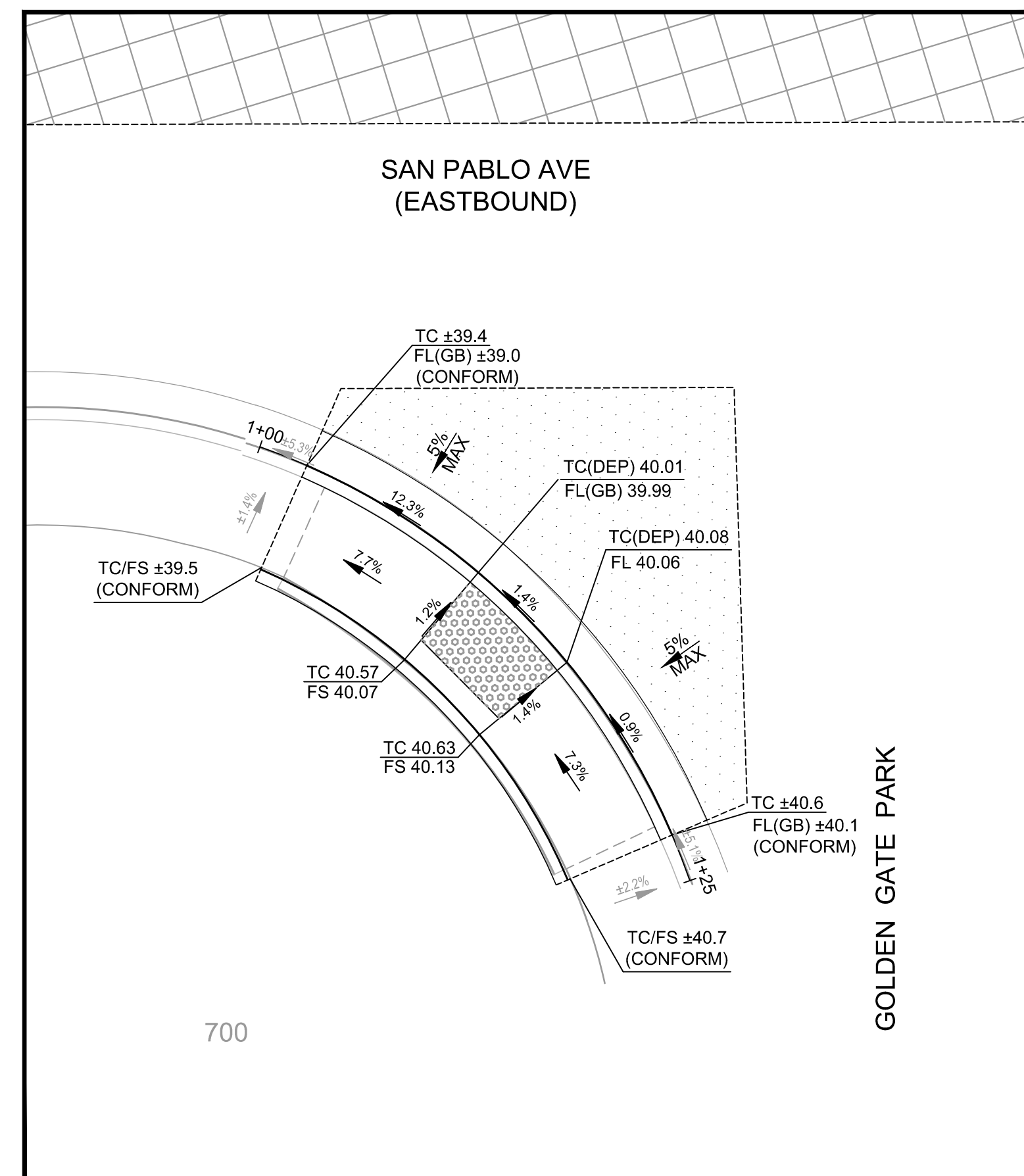

2 GRADING DETAIL - SW GOLDEN GATE PARK CURB RAMP
SCALE: 1" = 5'

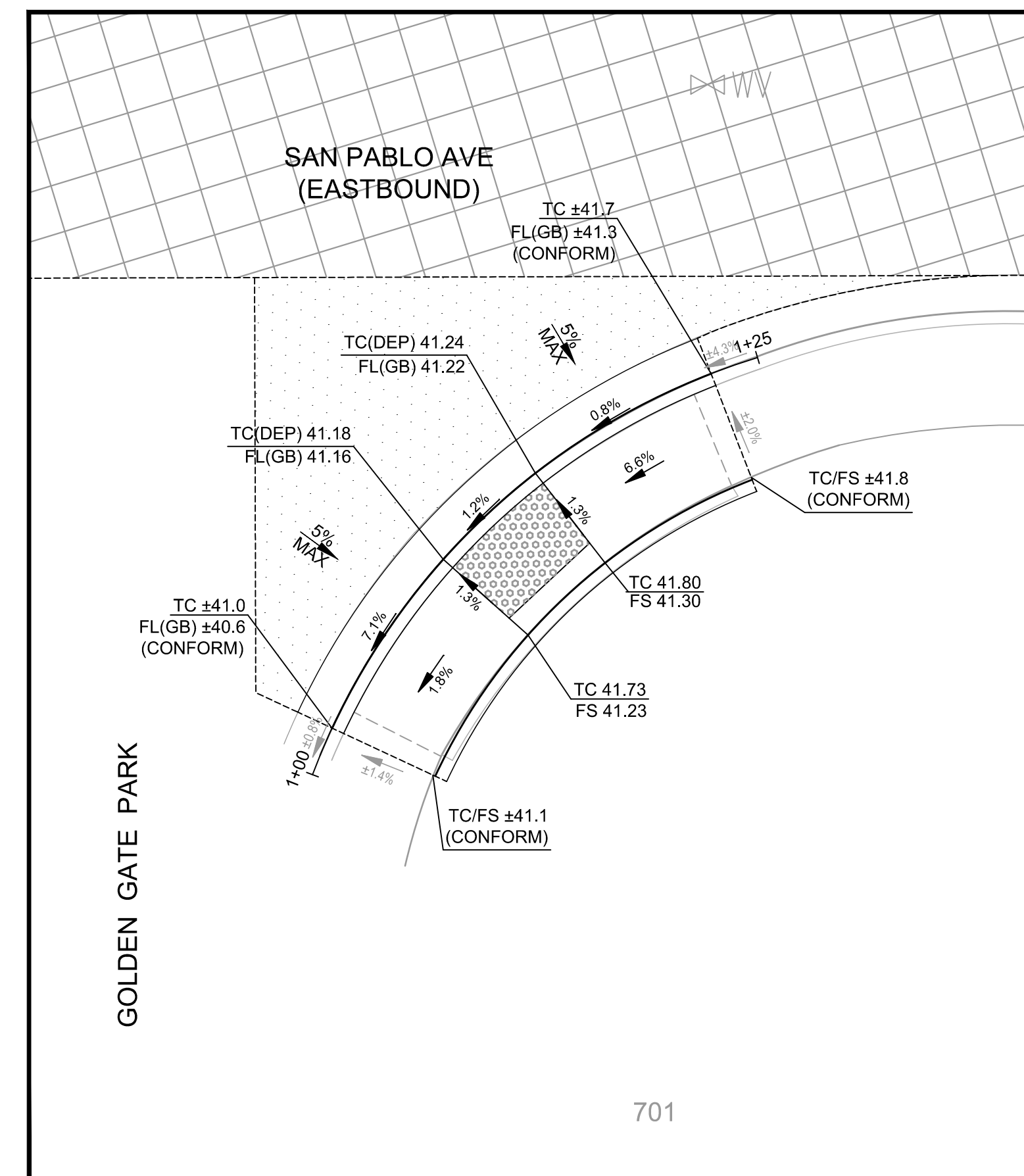

4 GRADING DETAIL - SE GOLDEN GATE PARK CURB RAMP
SCALE: 1" = 5'

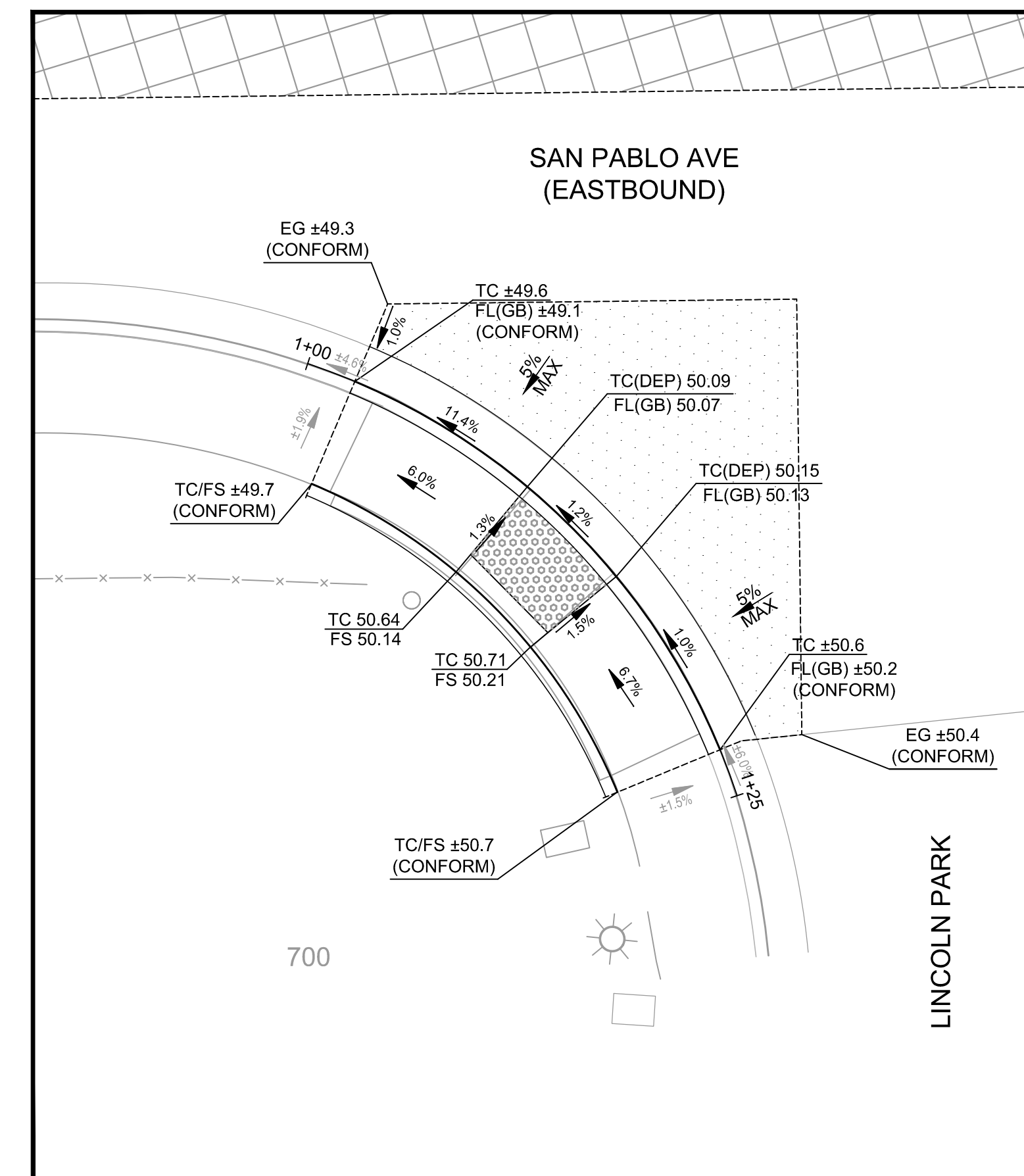

6 GRADING DETAIL - SW LINCOLN PARK CURB RAMP
SCALE: 1" = 5'

SW GOLDEN GATE PARK ALIGNMENT						
TAG	STATION	NORTHING	EASTING	DELTA / BEARING	DISTANCE	RADIUS
C1	1+00.00	2192255.40	6037799.73	S72° 44' 18"E	25.00	28.00

SE GOLDEN GATE PARK ALIGNMENT						
TAG	STATION	NORTHING	EASTING	DELTA / BEARING	DISTANCE	RADIUS
C2	1+00.00	2192273.86	6037848.83	N18° 51' 35"E	25.00	27.50

SW LINCOLN PARK ALIGNMENT						
TAG	STATION	NORTHING	EASTING	DELTA / BEARING	DISTANCE	RADIUS
C3	1+00.00	2192384.99	6038042.31	S72° 49' 36"E	25.00	27.00

KEYNOTES

- RESET LANDSCAPE STONE AND CONCRETE EDGER TO MATCH EXISTING
- PROTECT IN PLACE EX. TREE

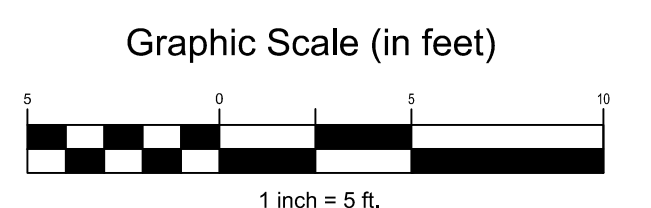

Rev	Date	Description	Designed	Drawn	Checked
-	07/14/21	BID SET	PW	RS	RS

CSW ST2
CSW/Stuber-Stroeh Engineering Group, Inc.
 Civil & Structural Engineers | Surveying & Mapping | Environmental Planning
 Land Planning | Construction Management
 45 Leveroni Court, Novato, CA 94949
 Tel: 415.883.9850, Fax: 415.883.9835
 http://www.cswst2.com

City: Pinole
 County: Contra Costa
 State: California

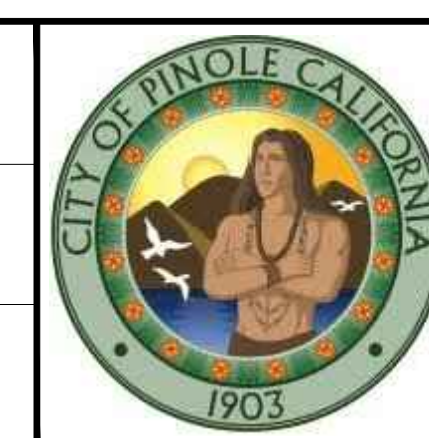

SAN PABLO AVE REHABILITATION
CURB RAMP PLAN
(GOLDEN GATE PARK / LINCOLN PARK)
CITY OF PINOLE

Prepared Under the Direction of:

 RICHARD J. SOUZA
 No. 67892
 CIVIL
 STATE OF CALIFORNIA

Sheet: **C3.00**
 Scale: 1" = 5'
 Date: 07/14/2021
 Project #: R01801
 Sheet #: 6 of 14

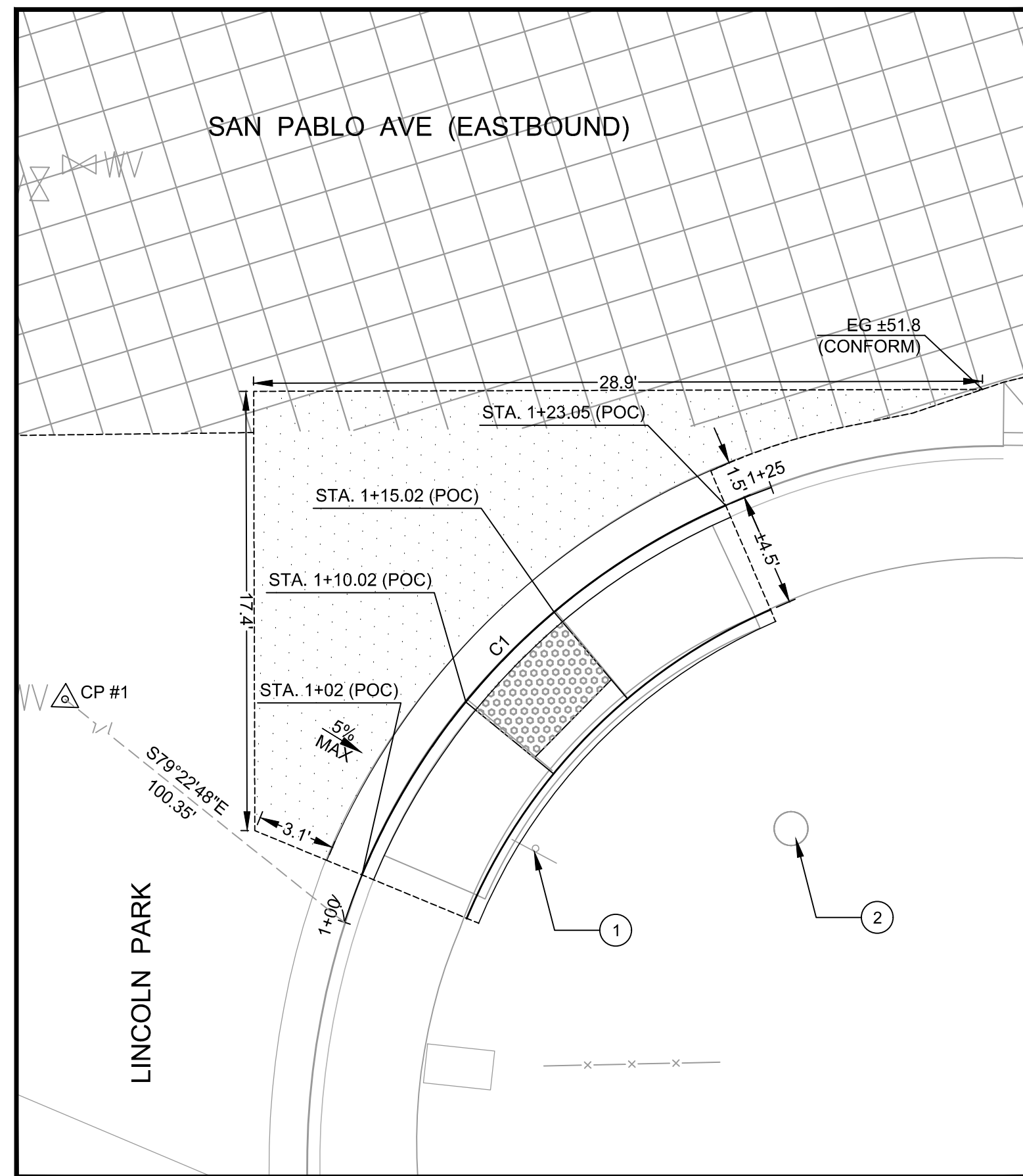

1 HORIZONTAL CONTROL - SE LINCOLN PARK CURB RAMP
SCALE: 1" = 5'

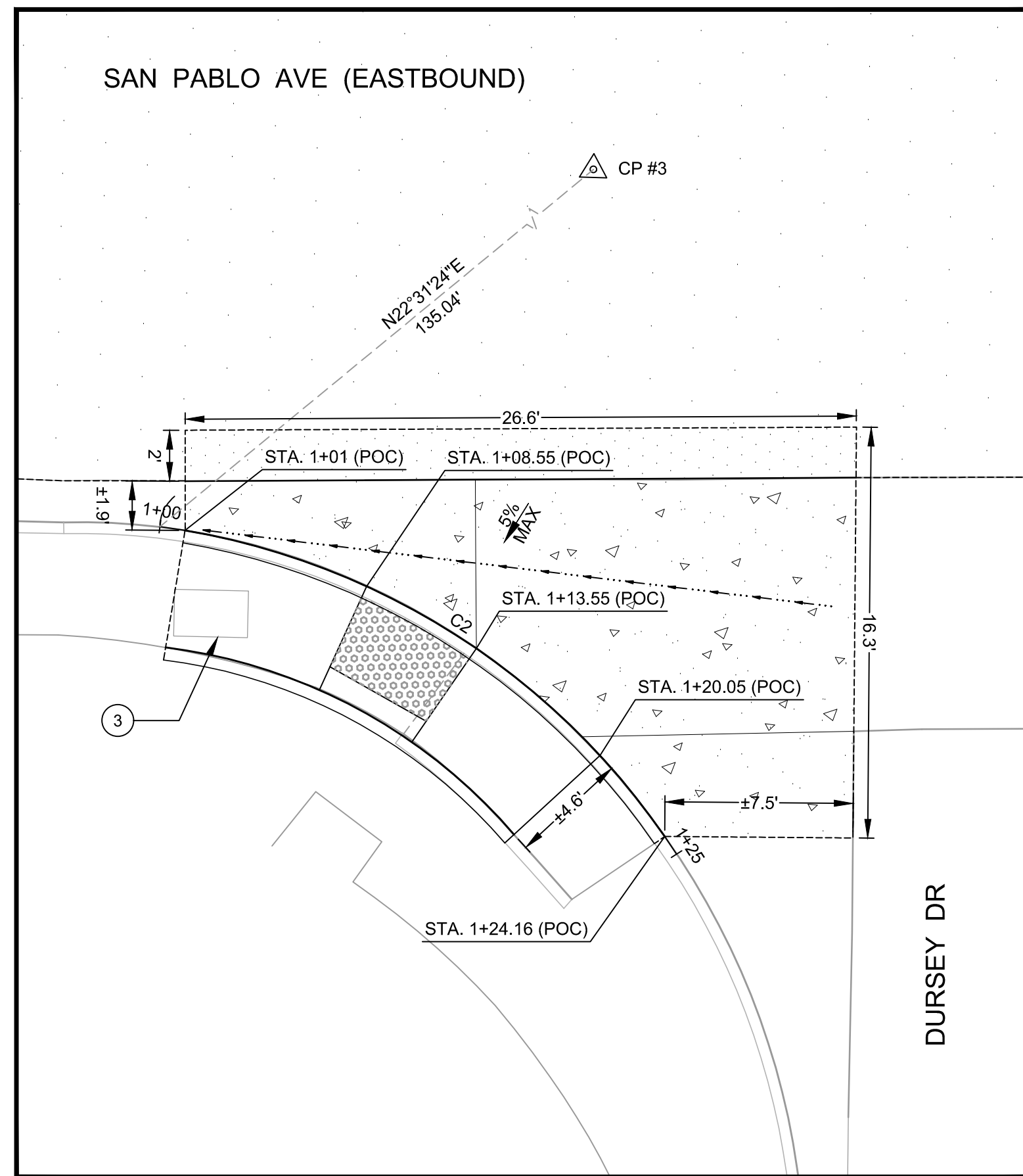

3 HORIZONTAL CONTROL - SW DURSEY DR CURB RAMP
SCALE: 1" = 5'

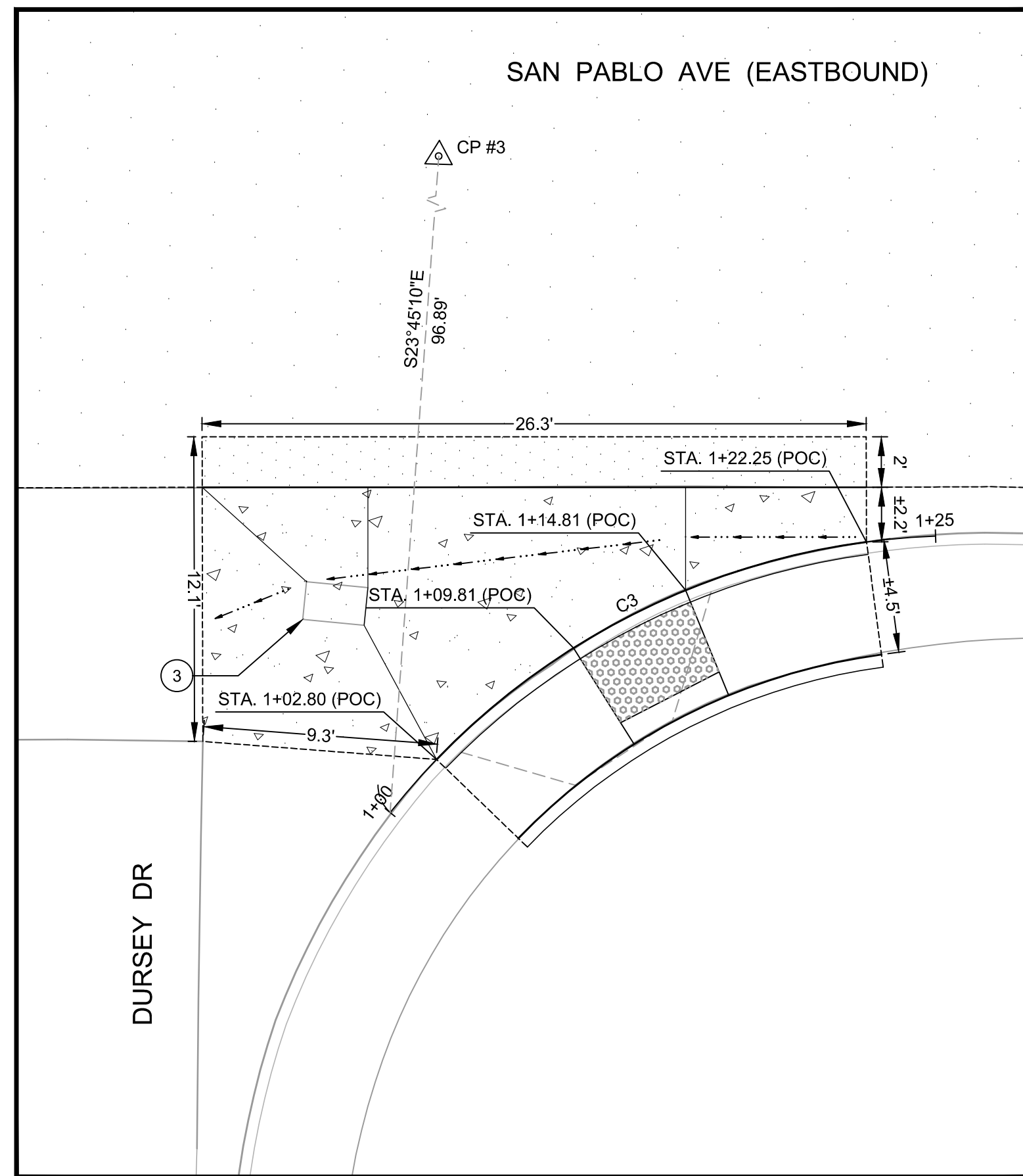

5 HORIZONTAL CONTROL - SE DURSEY DR CURB RAMP
SCALE: 1" = 5'

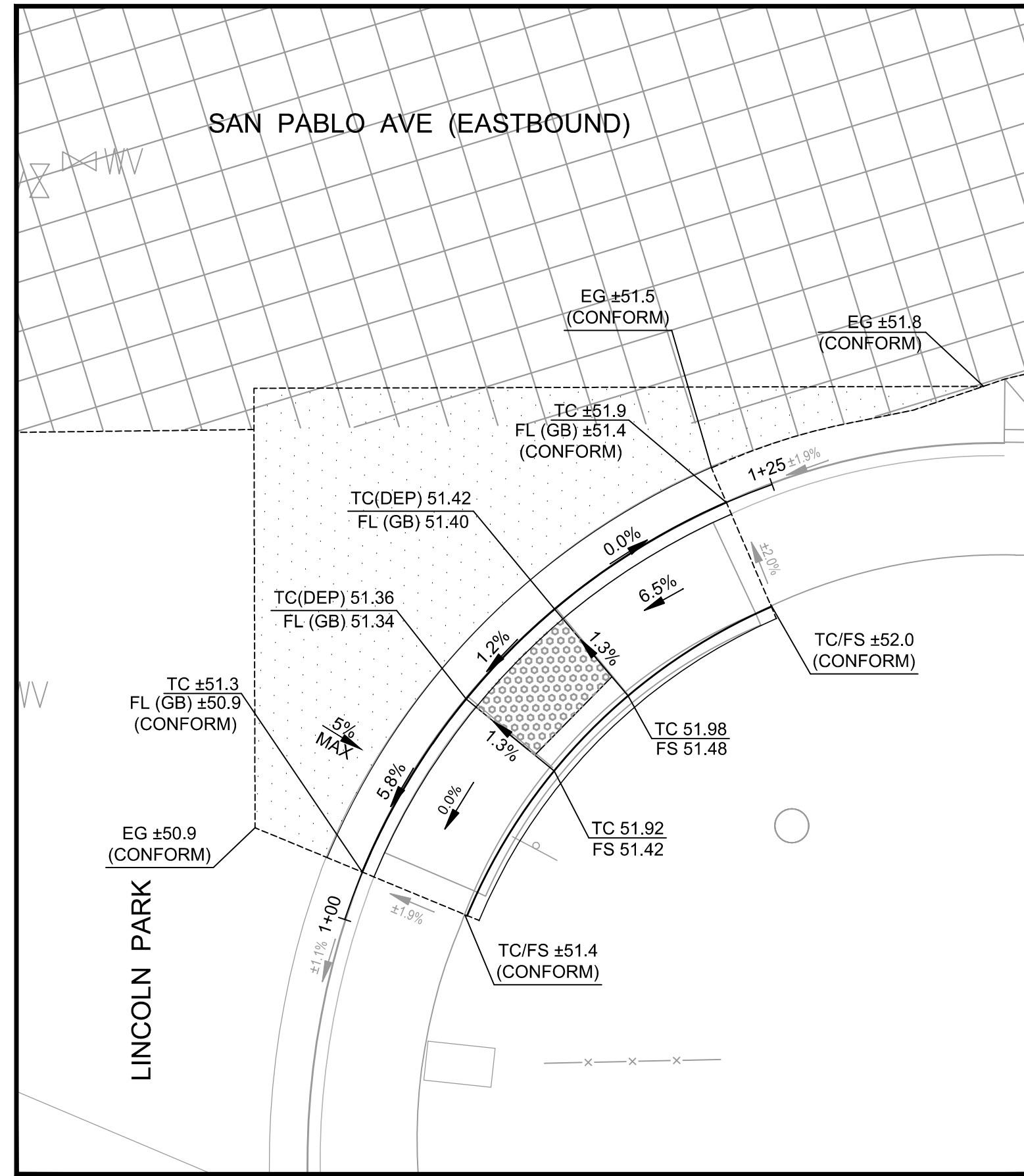

2 GRADING DETAIL - SE LINCOLN PARK CURB RAMP
SCALE: 1" = 5'

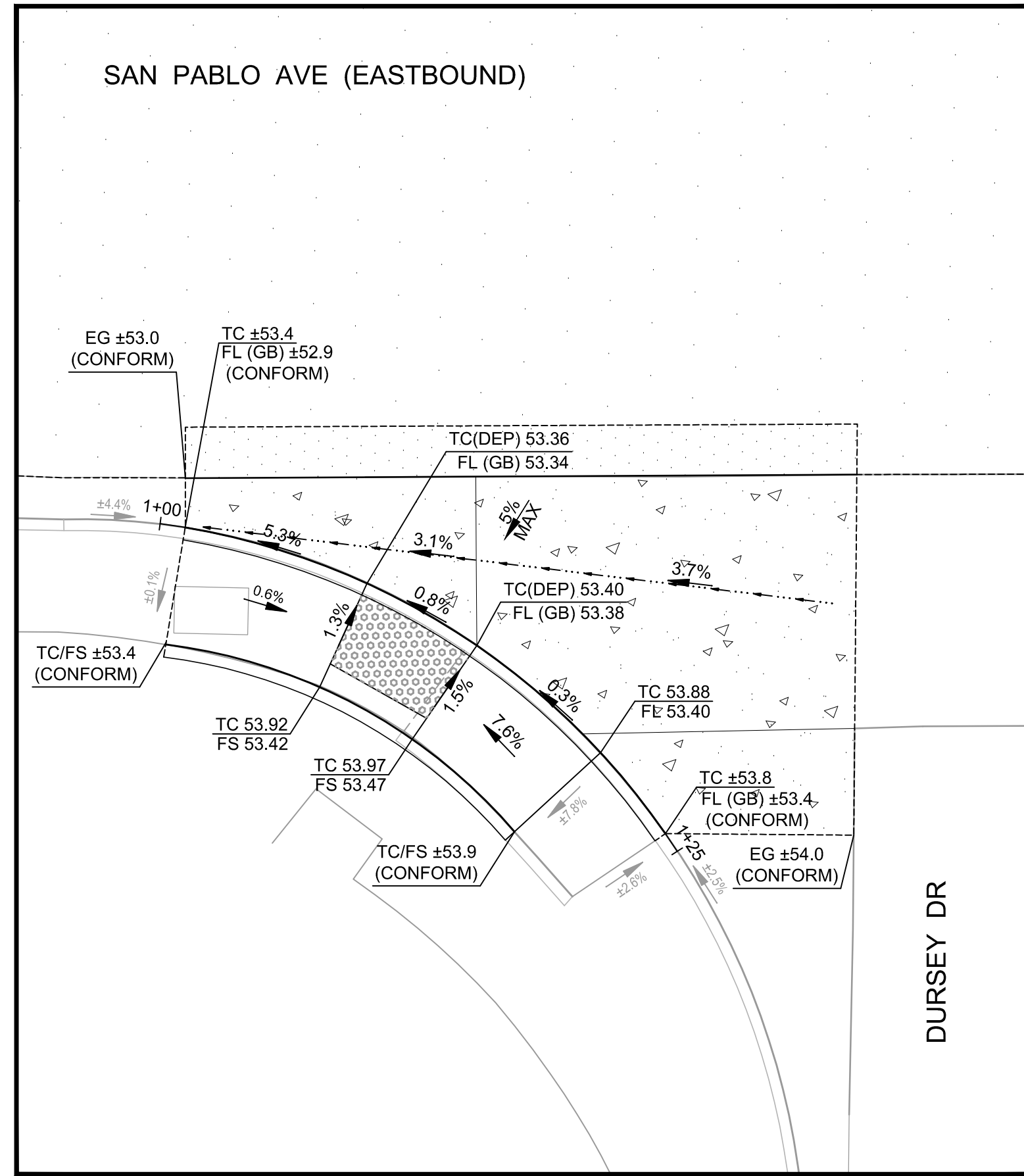

4 GRADING DETAIL - SW DURSEY DR CURB RAMP
SCALE: 1" = 5'

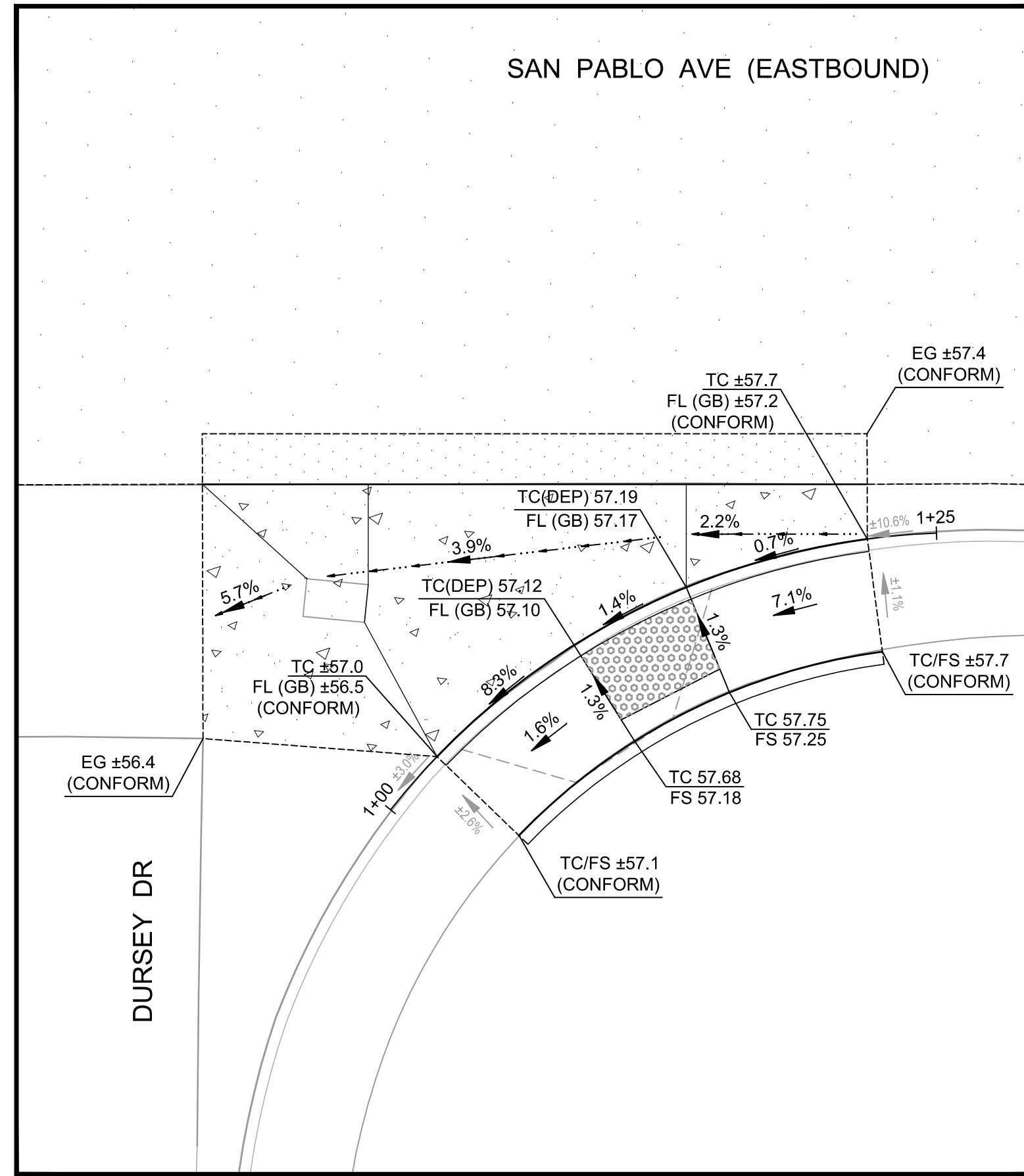

6 GRADING DETAIL - SE DURSEY DR CURB RAMP
SCALE: 1" = 5'

SE LINCOLN PARK ALIGNMENT						
TAG	STATION	NORTHING	EASTING	DELTA / BEARING	DISTANCE	RADIUS
C1	1+00.00	2192402.24	6038092.25	N16° 30' 18"E	25.00	27.50

SW DURSEY DR ALIGNMENT						
TAG	STATION	NORTHING	EASTING	DELTA / BEARING	DISTANCE	RADIUS
C2	1+00.00	2192446.33	6038135.50	S85° 38' 05"E	25.00	29.00

SE DURSEY DR ALIGNMENT						
TAG	STATION	NORTHING	EASTING	DELTA / BEARING	DISTANCE	RADIUS
C3	1+00.00	2192482.39	6038226.25	N35° 07' 51"E	25.00	29.00

KEYNOTES

- ① PROTECT IN PLACE EX. SIGN
- ② PROTECT IN PLACE EX. TREE
- ③ ADJUST EX. UTILITY TO FINISHED GRADE

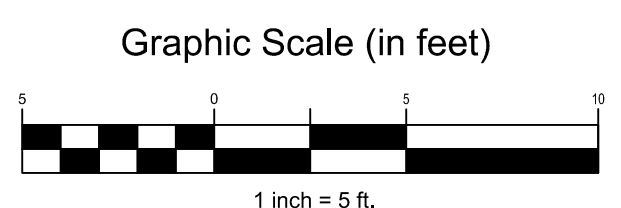

Rev	Date	Description	Designed	Drawn	Checked
-	07/14/21	BID SET	PW	RS	RS

CSW | ST2
CSW/Stuber-Stroeh Engineering Group, Inc.
 Civil & Structural Engineers | Surveying & Mapping | Environmental Planning
 Land Planning | Construction Management
 45 Leveroni Court | Novato, CA 94949 | tel: 415.883.9850 | fax: 415.883.9835
 http://www.cswst2.com | ©2021

City	Pinole
County	Contra Costa
State	California



SAN PABLO AVE REHABILITATION
CURB RAMP PLAN
 (LINCOLN PARK / DURSEY DR)
 CITY OF PINOLE

Prepared Under the Direction of:

 RICHARD J. SOUZA
 No. 67892
 CIVIL
 STATE OF CALIFORNIA

Sheet	C3.01
Scale:	1" = 5'
Date:	07/14/2021
Project #:	R01801
Sheet #:	7 of 14

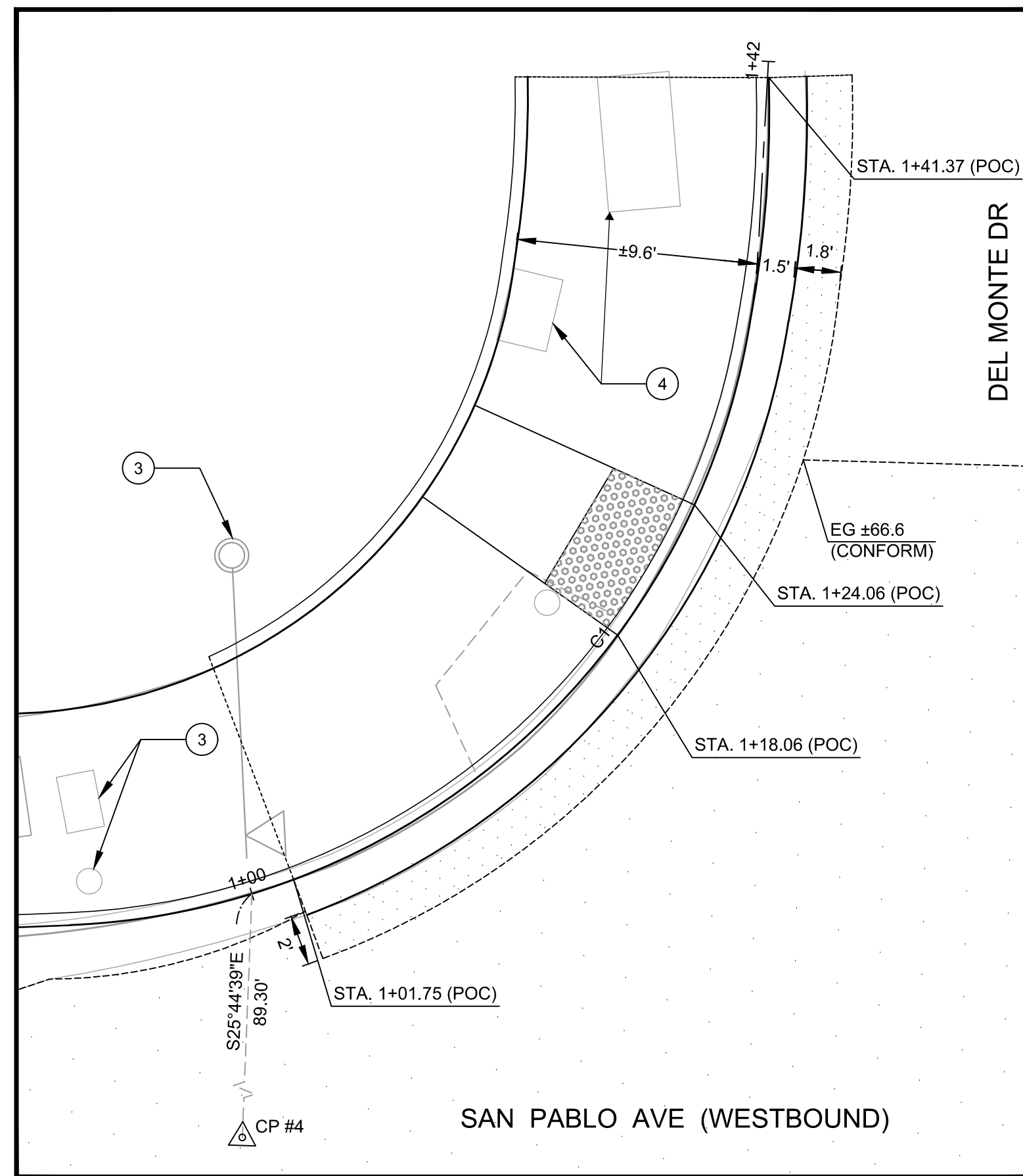

1 HORIZONTAL CONTROL - NW DEL MONTE DR CURB RAMP
SCALE: 1" = 5'

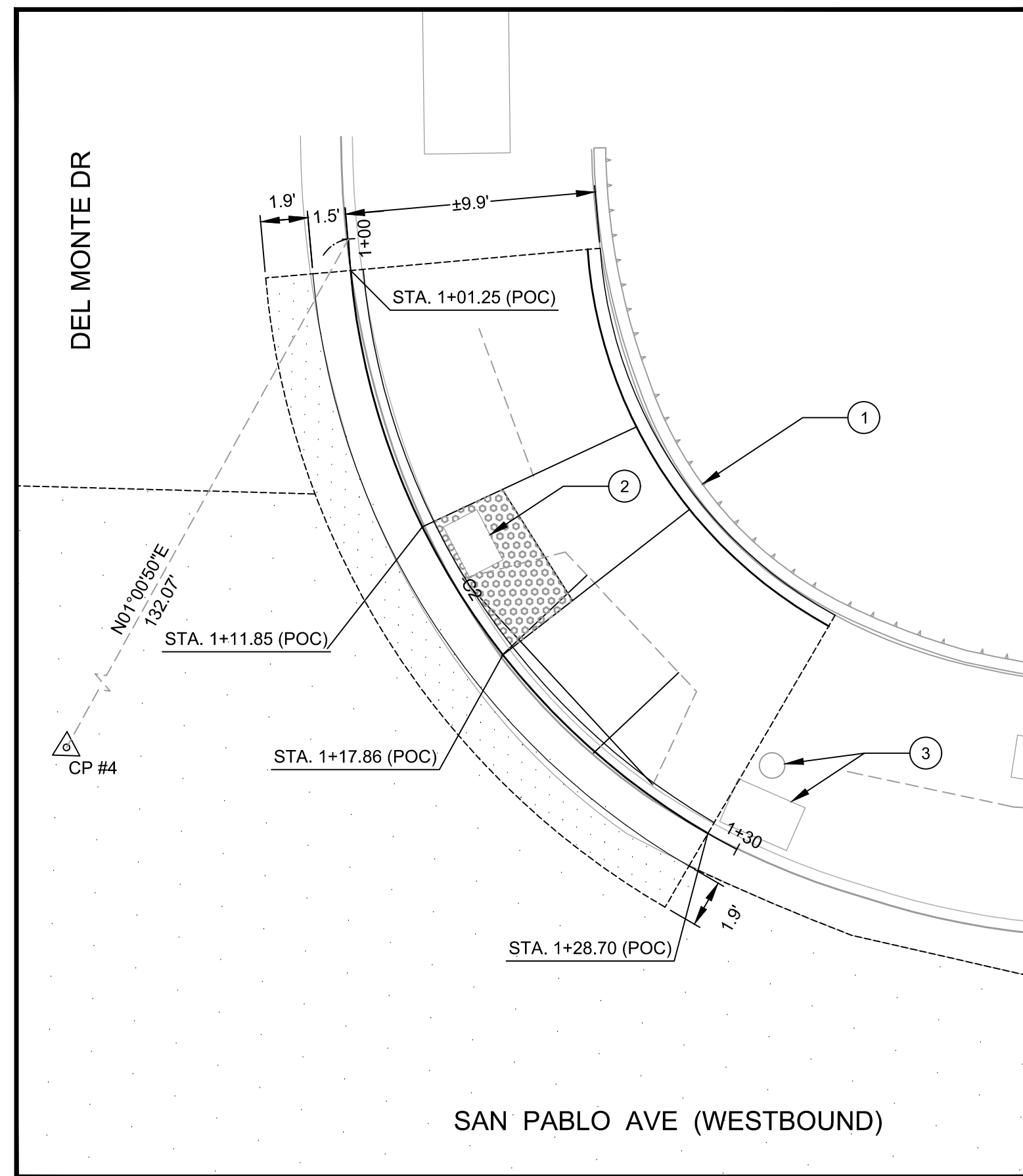

3 HORIZONTAL CONTROL - NE DEL MONTE DR CURB RAMP
SCALE: 1" = 5'

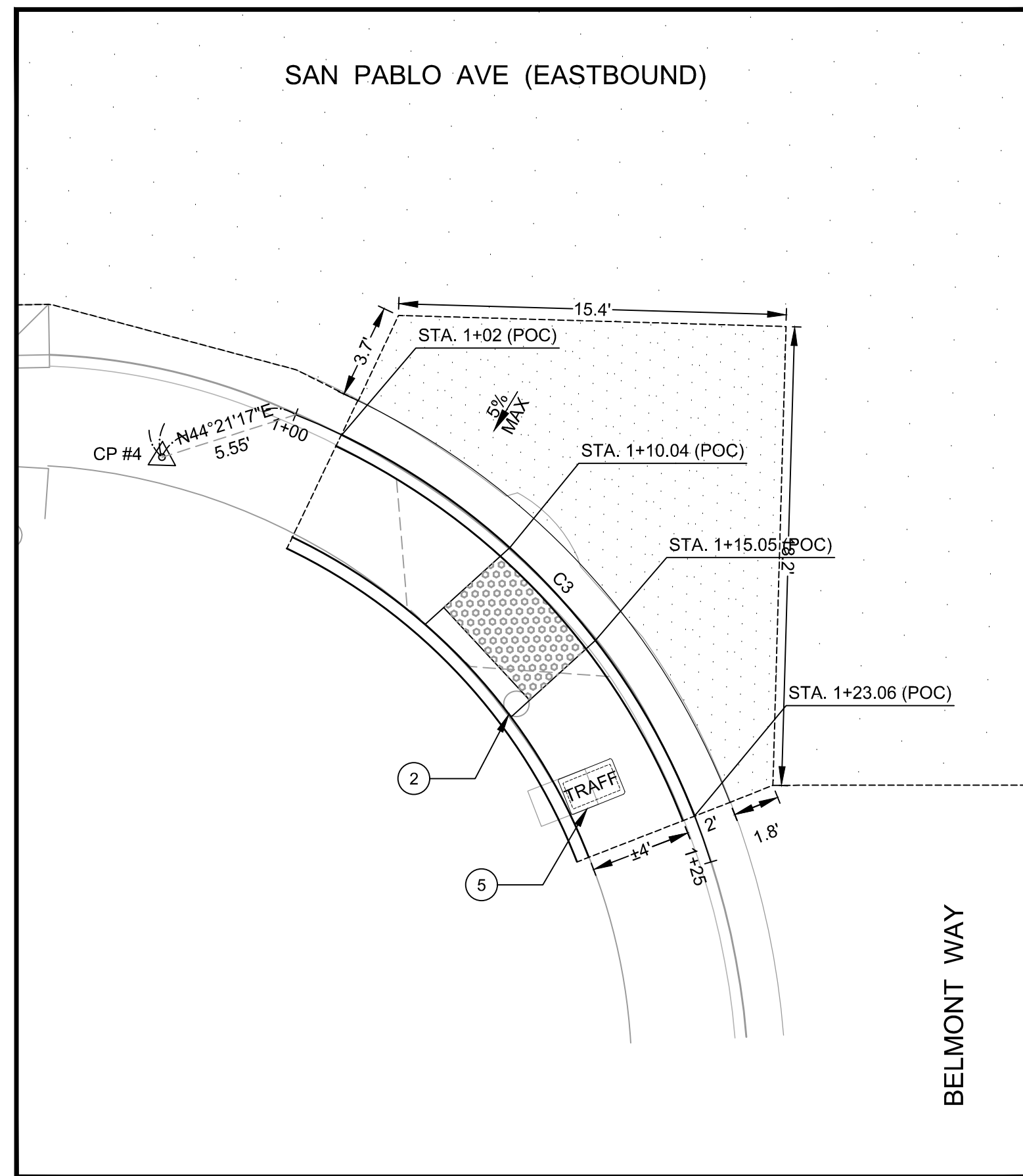

5 HORIZONTAL CONTROL - SW BELMONT WAY CURB RAMP
SCALE: 1" = 5'

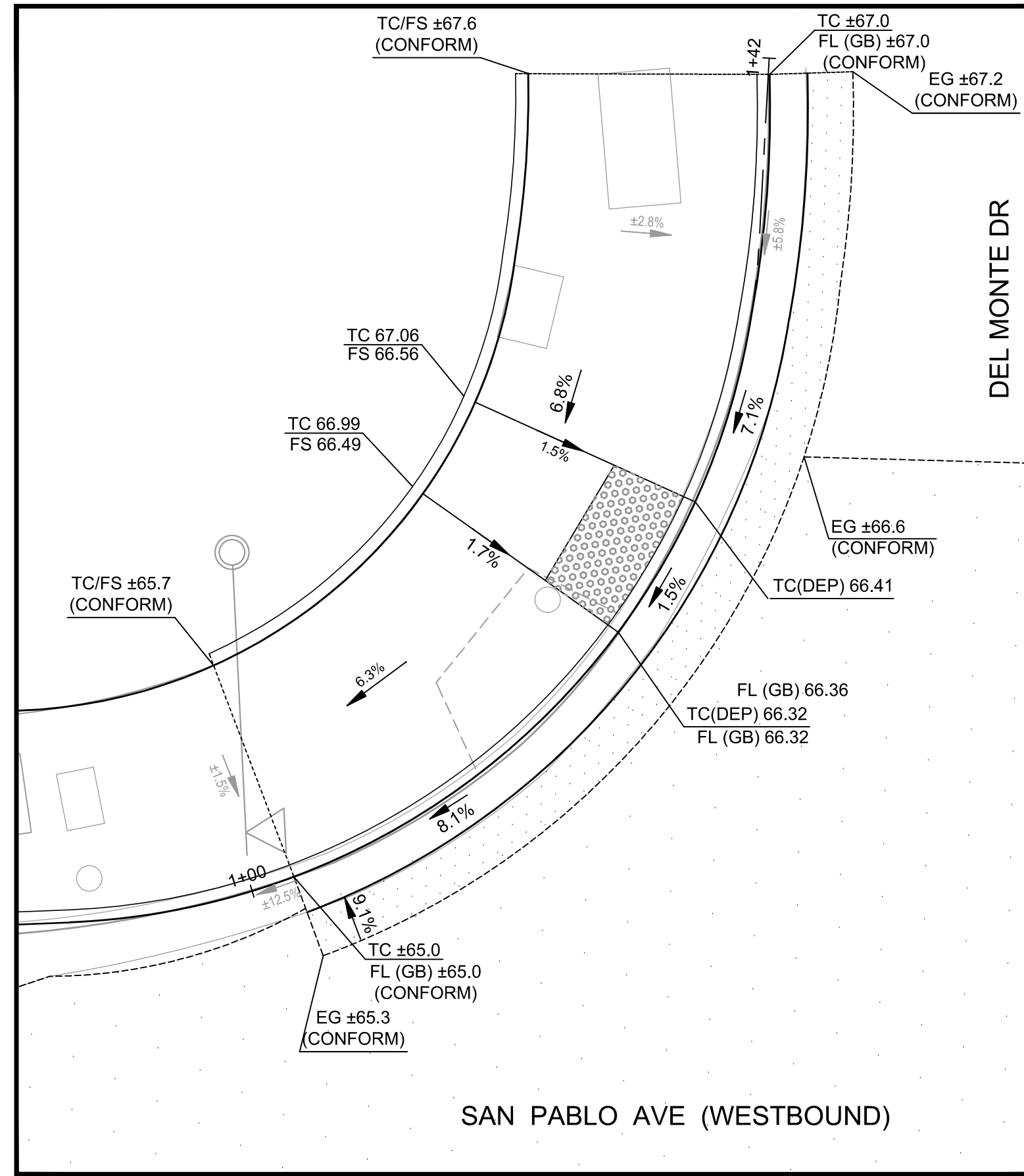

2 GRADING DETAIL - NW DEL MONTE DR CURB RAMP
SCALE: 1" = 5'

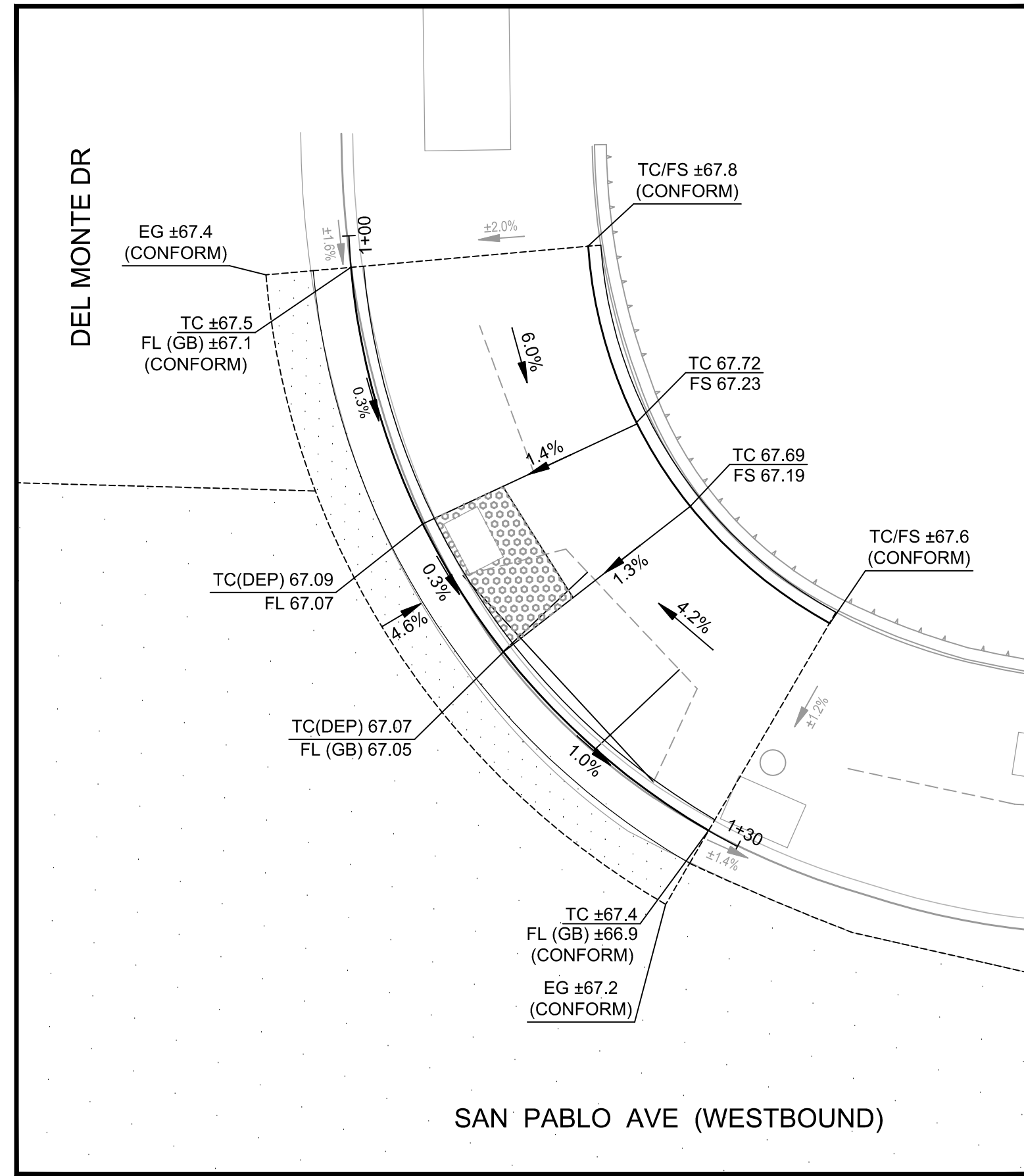

4 GRADING DETAIL - NE DEL MONTE DR CURB RAMP
SCALE: 1" = 5'

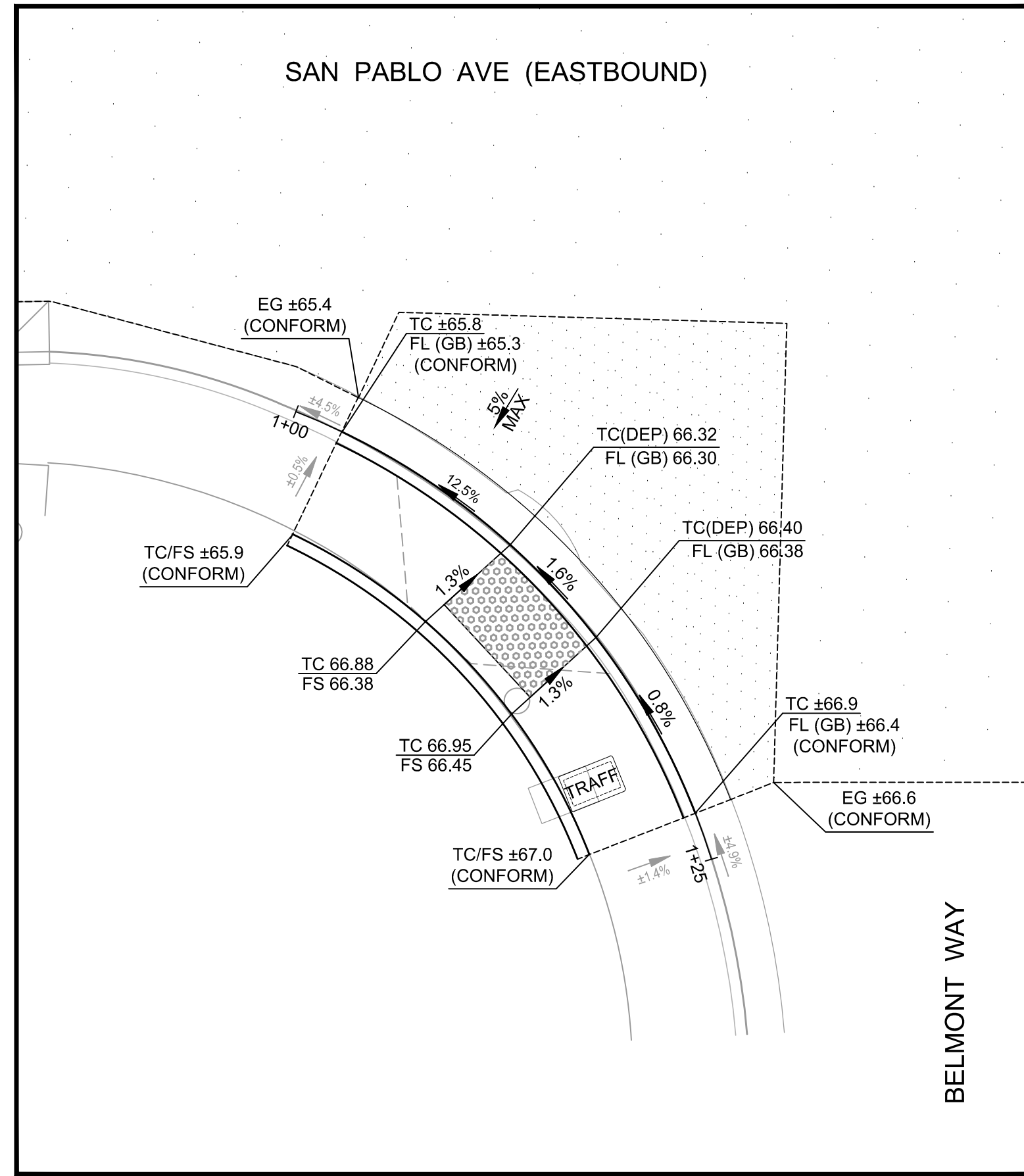

6 GRADING DETAIL - SW BELMONT WAY CURB RAMP
SCALE: 1" = 5'

NW DEL MONTE DR ALIGNMENT						
TAG	STATION	NORTHING	EASTING	DELTA / BEARING	DISTANCE	RADIUS
C1	1+00.00	2192696.59	6038422.14	N9° 42' 28"E	35.00	28.50

NE DEL MONTE DR ALIGNMENT						
TAG	STATION	NORTHING	EASTING	DELTA / BEARING	DISTANCE	RADIUS
C2	1+00.00	2192748.21	6038463.26	S60° 28' 06"E	30.00	28.75

SW BELMONT WAY ALIGNMENT						
TAG	STATION	NORTHING	EASTING	DELTA / BEARING	DISTANCE	RADIUS
C3	1+00.00	2192620.13	6038464.80	S70° 52' 58"E	25.00	28.00

- KEYNOTES**
- PROTECT IN PLACE EX. WALL
 - ADJUST EX. TRAFFIC SIGNALS, PUSH BUTTONS, AND PULLBOXES TO FINISHED GRADE
 - PROTECT IN PLACE EX. TRAFFIC SIGNALS, PUSH BUTTONS, AND PULLBOXES
 - ADJUST EX. UTILITY PULLBOX TO FINISHED GRADE
 - UTILITY PULLBOX TO BE RELOCATED

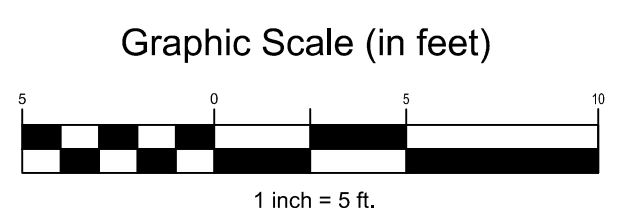

Rev	Date	Description	Designed	Drawn	Checked
-	07/14/21	BID SET	PW	RS	RS

CSW | ST2
CSW/Stuber-Stroeh Engineering Group, Inc.
 Civil & Structural Engineers | Surveying & Mapping | Environmental Planning
 Land Planning | Construction Management
 45 Leveroni Court, Novato, CA 94949 | tel: 415.883.9850 | fax: 415.883.9835
 http://www.cswst2.com

City Pinole
 County Contra Costa
 State California

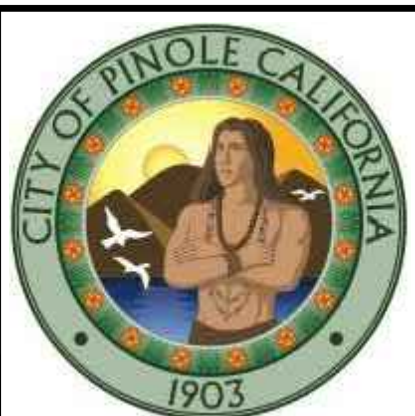

SAN PABLO AVE REHABILITATION
CURB RAMP PLAN
(DEL MONTE DR / BELMONT WAY)
CITY OF PINOLE

Prepared Under the Direction of:

 CIVIL ENGINEER

Sheet **C3.02**
 Scale: 1" = 5'
 Date: 07/14/2021
 Project #: R01801
 Sheet #: 8 of 14

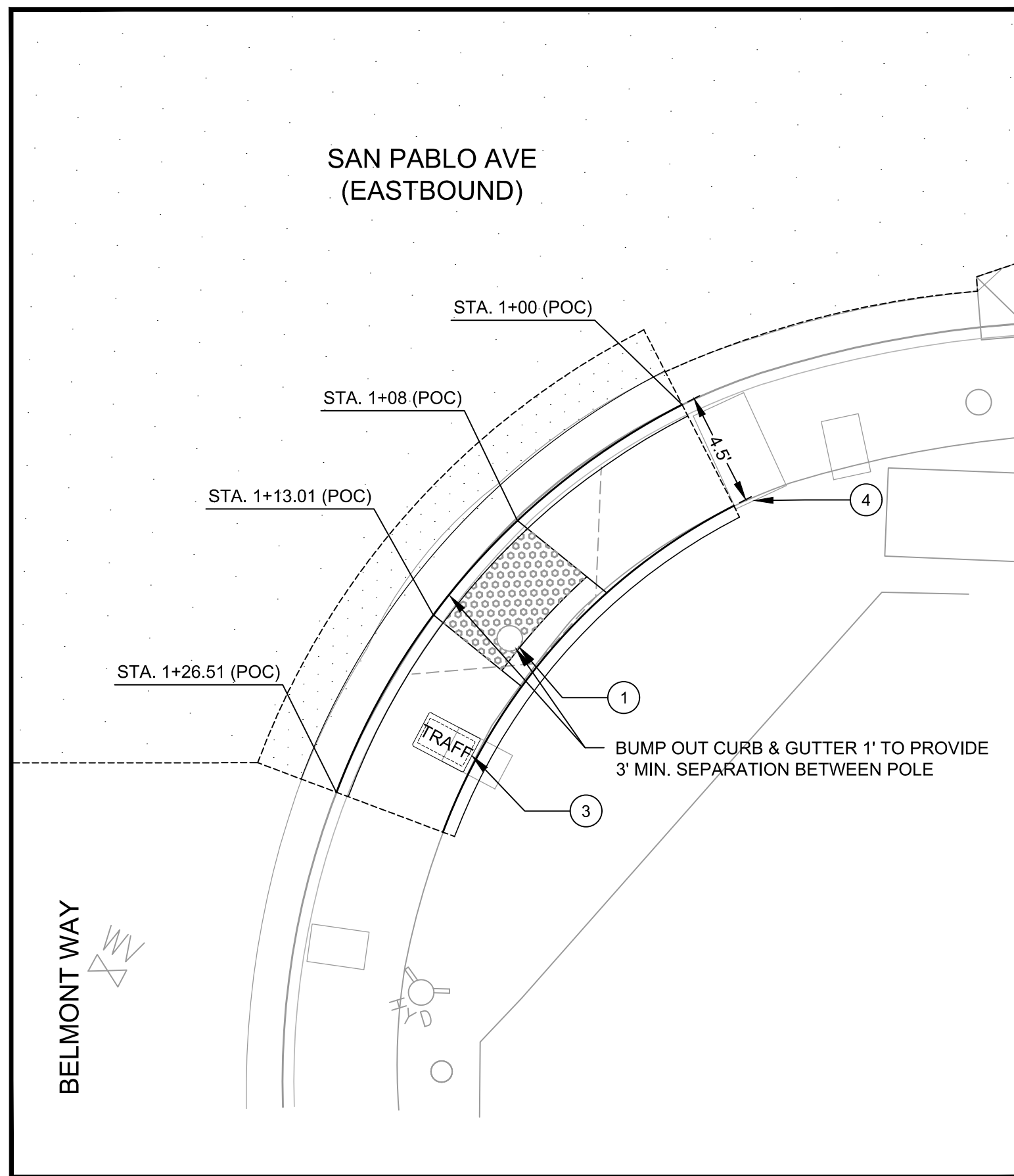

1 HORIZONTAL CONTROL - SE BELMONT WAY CURB RAMP
SCALE: 1" = 5'

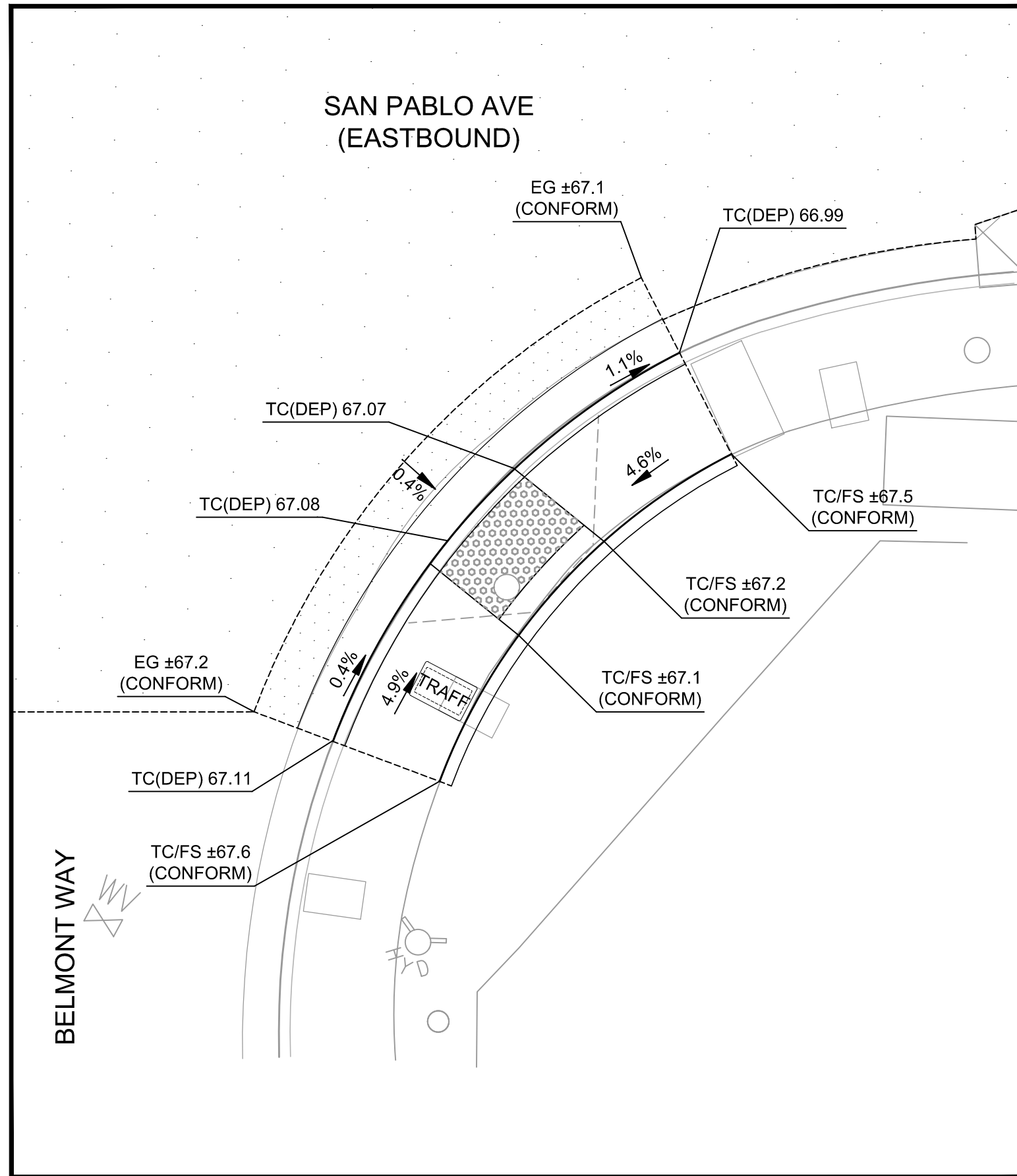

2 GRADING DETAIL - SE BELMONT WAY CURB RAMP
SCALE: 1" = 5'

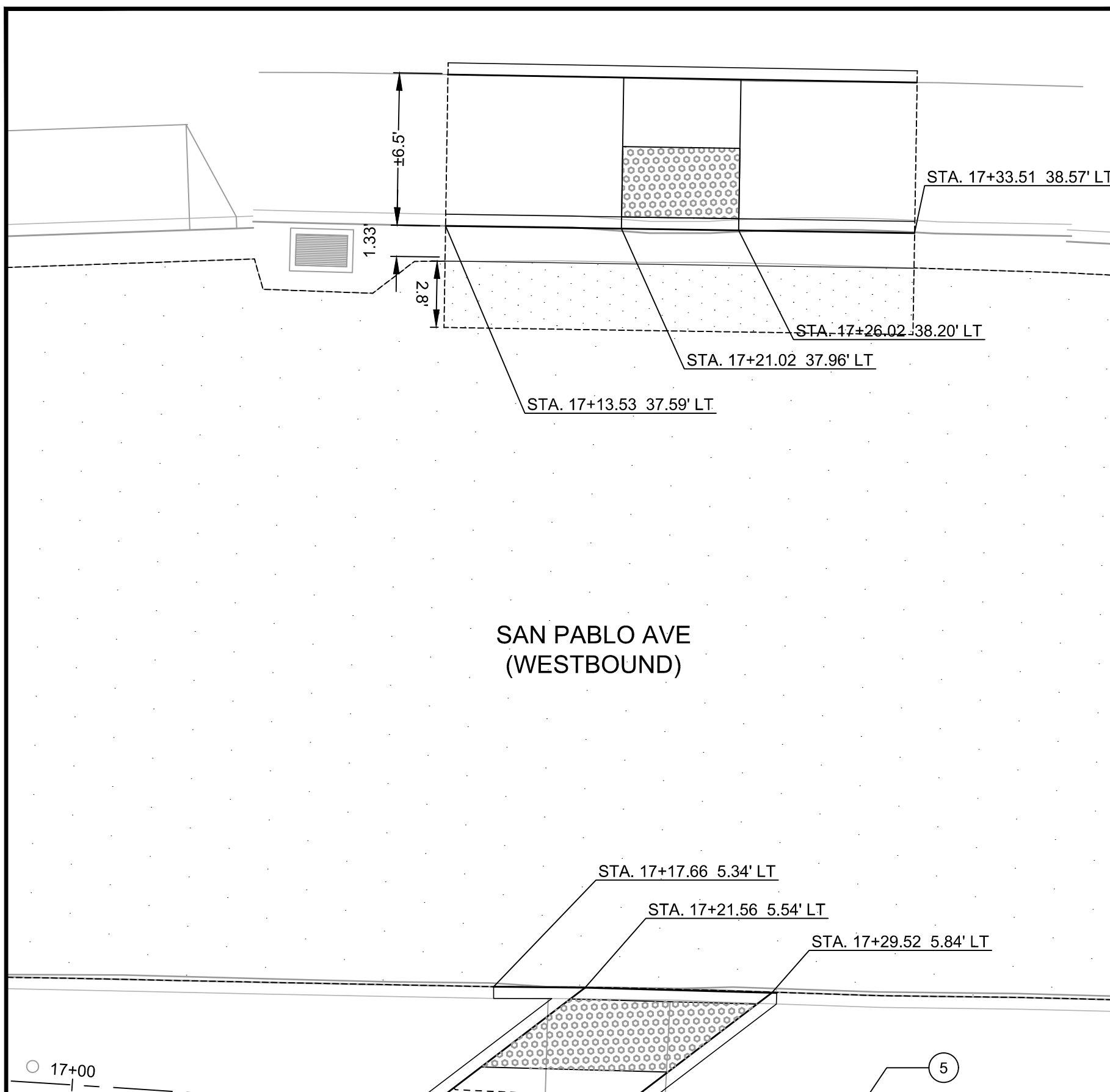

3 HORIZONTAL CONTROL - SAN PABLO AVE MID-BLOCK CROSSING
SCALE: 1" = 5'

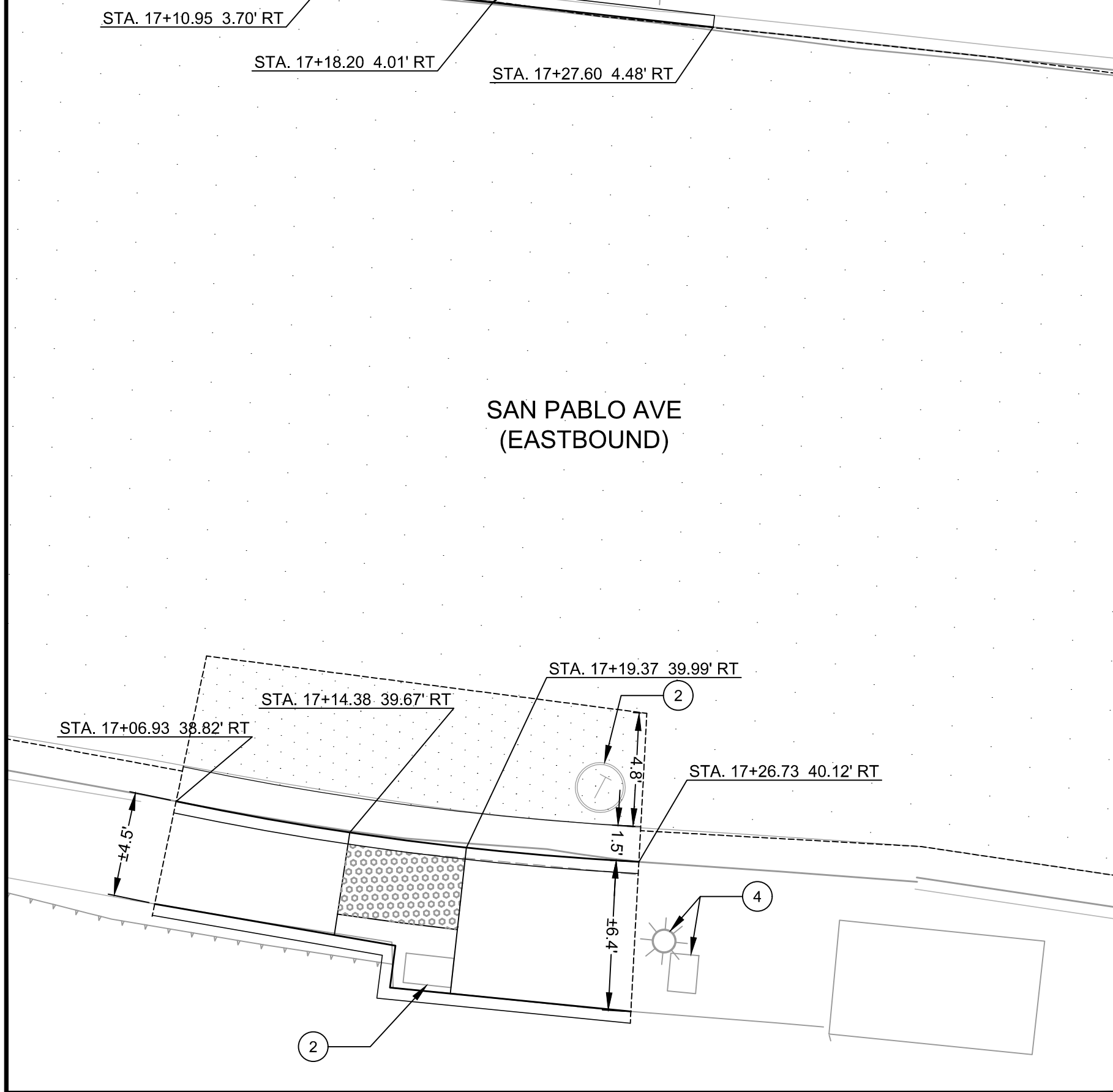

4 GRADING DETAIL - SAN PABLO AVE MID-BLOCK CROSSING
SCALE: 1" = 5'

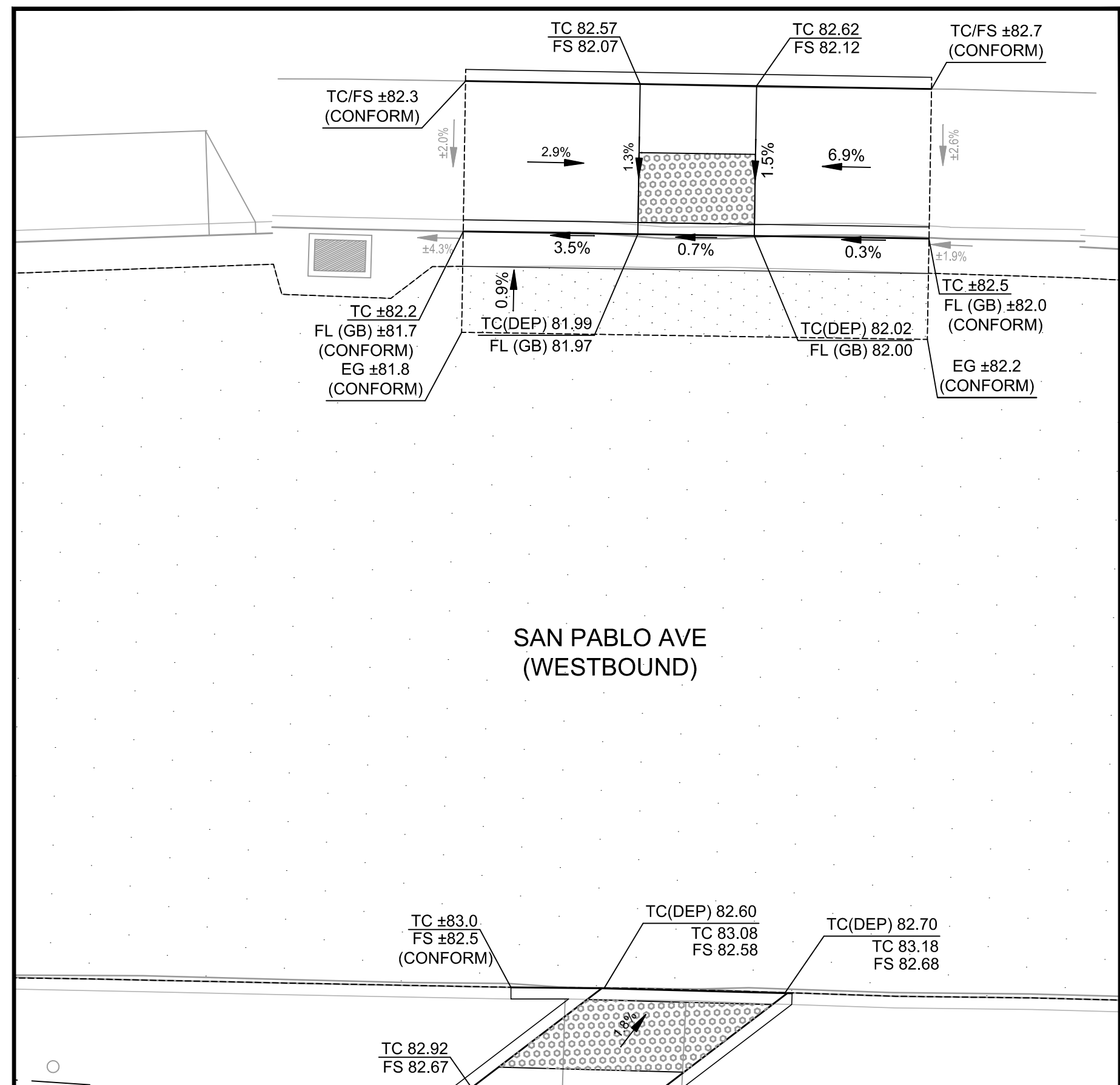

3 HORIZONTAL CONTROL - SAN PABLO AVE MID-BLOCK CROSSING
SCALE: 1" = 5'

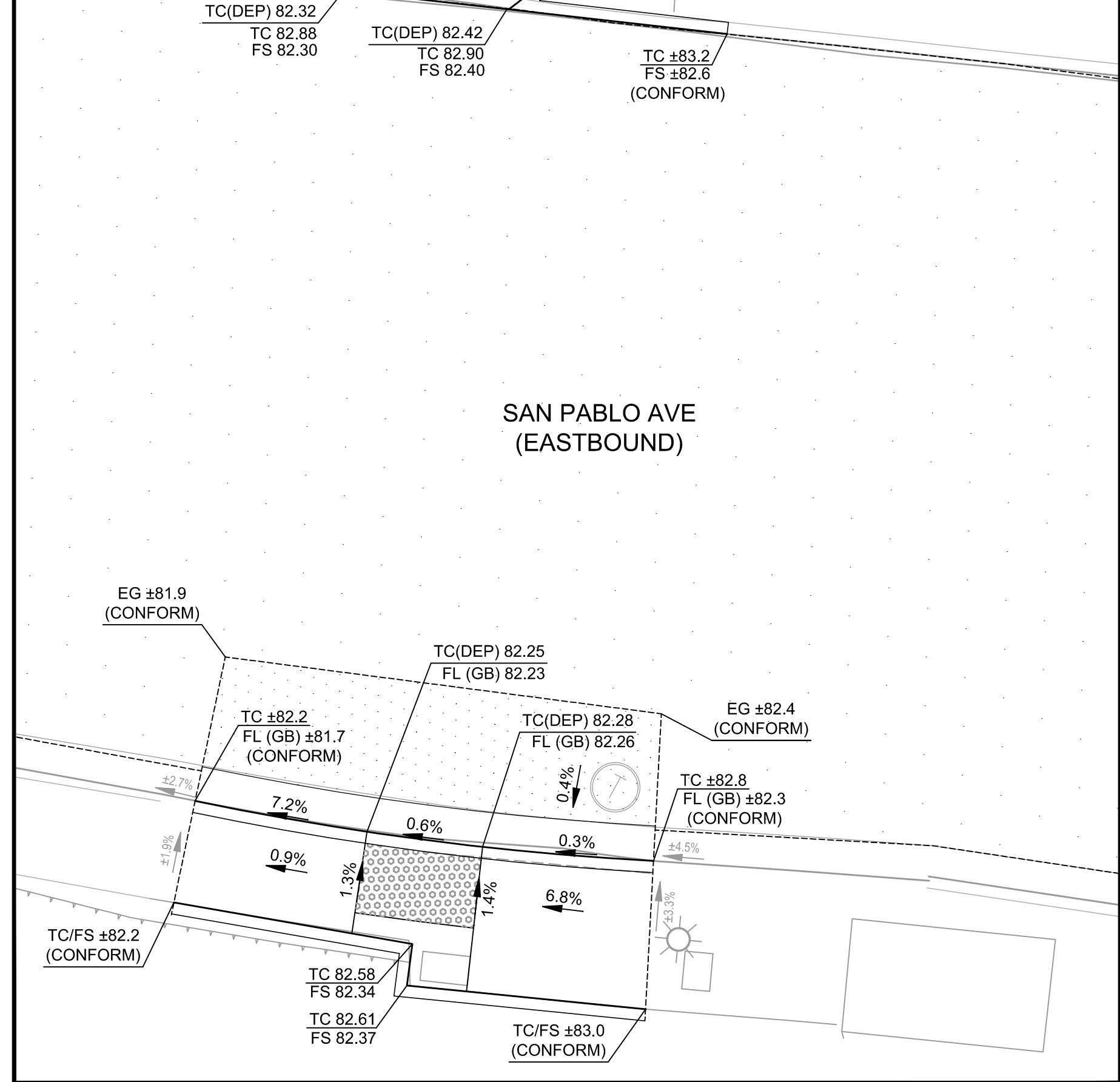

4 GRADING DETAIL - SAN PABLO AVE MID-BLOCK CROSSING
SCALE: 1" = 5'

TAG	STATION	NORTHING	EASTING	DELTA / BEARING	DISTANCE	RADIUS
-----	---------	----------	---------	-----------------	----------	--------

- KEYNOTES**
- 1 ADJUST EX. TRAFFIC SIGNALS TO FINISHED GRADE
 - 2 ADJUST EX. UTILITY TO FINISHED GRADE
 - 3 UTILITY PULLBOX TO BE RELOCATED
 - 4 PROTECT IN PLACE EX. UTILITY
 - 5 PROTECT IN PLACE EX. TREE

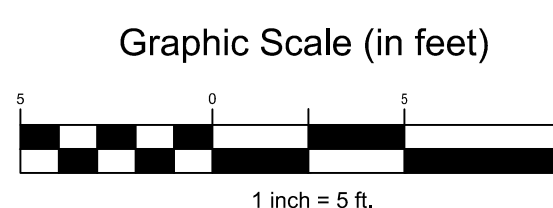

Rev	Date	Description	Designed	Drawn	Checked
-	07/14/21	BID SET	PW	RS	RS

CSW | ST2
CSW/Stuber-Stroeh Engineering Group, Inc.
 Civil & Structural Engineers | Surveying & Mapping | Environmental Planning
 Land Planning | Construction Management
 45 Leveroni Court Novato, CA 94949
 tel: 415.883.9850 fax: 415.883.9835
 http://www.cswst2.com

City Pinole
 County Contra Costa
 State California



SAN PABLO AVE REHABILITATION
CURB RAMP PLAN
(BELMONT WAY / MID-BLOCK X-ING)
CITY OF PINOLE

Prepared Under the Direction of:

 Sheet **C3.03**
 Scale: 1" = 5'
 Date: 07/14/2021
 Project #: R01801
 Sheet #: 9 of 14

NW CRESTVIEW DR ALIGNMENT						
TAG	STATION	NORTHING	EASTING	DELTA / BEARING	DISTANCE	RADIUS
C1	1+00.00	2193276.48	6039584.97	N31° 45' 26"E	30.00	20.00

NE CRESTVIEW DR ALIGNMENT						
TAG	STATION	NORTHING	EASTING	DELTA / BEARING	DISTANCE	RADIUS
C2	1+00.00	2193323.30	6039624.09	???	7.54	???
C3	1+07.54	2193316.85	6039627.99	S38° 00' 50"E	8.54	35.50

KEYNOTES

- ① ADJUST EX. UTILITY TO FINISHED GRADE
- ② PROTECT IN PLACE EX. GAS PIPELINE

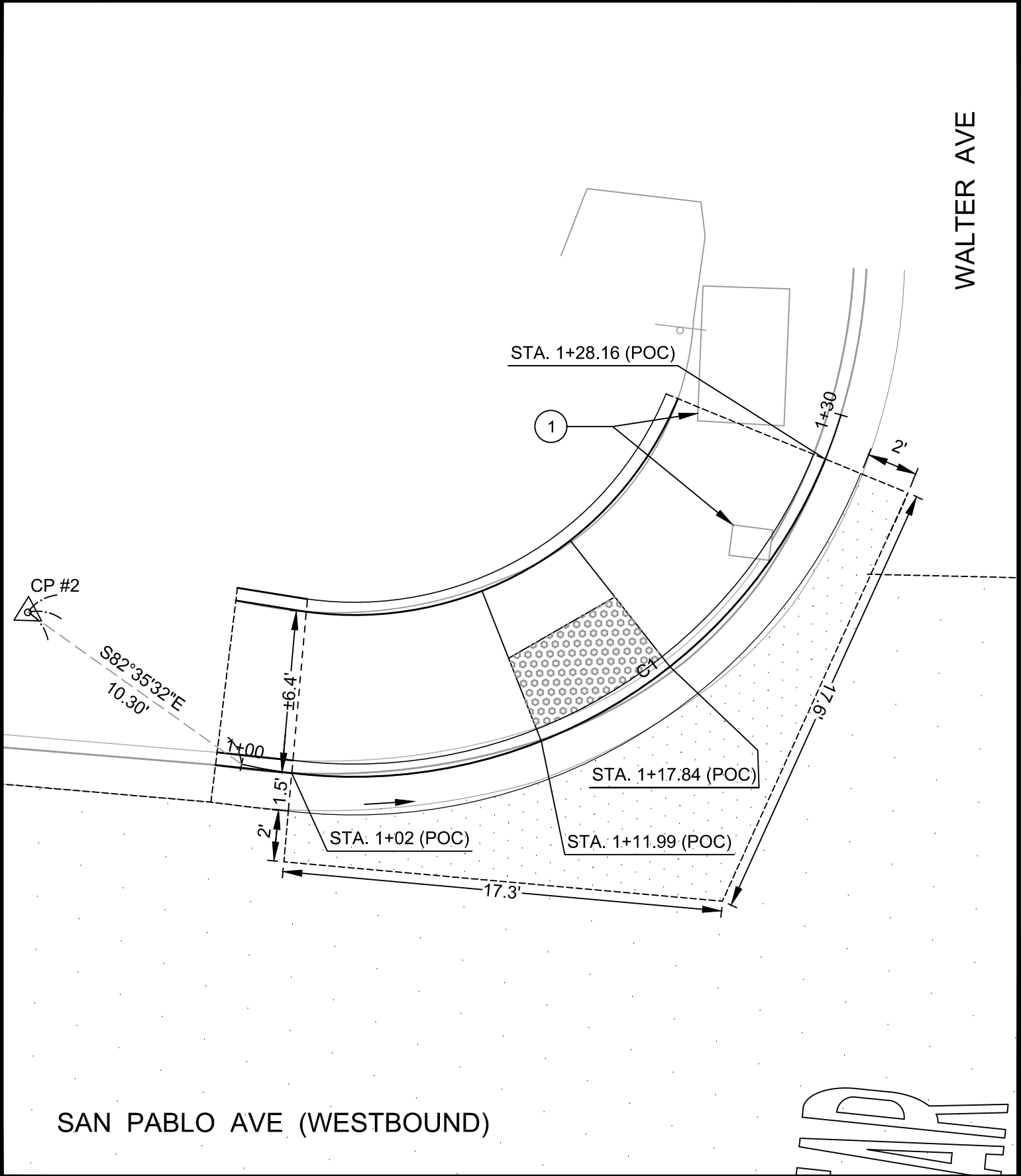

① HORIZONTAL CONTROL - NW WALTER AVE CURB RAMP

SCALE: 1" = 5'

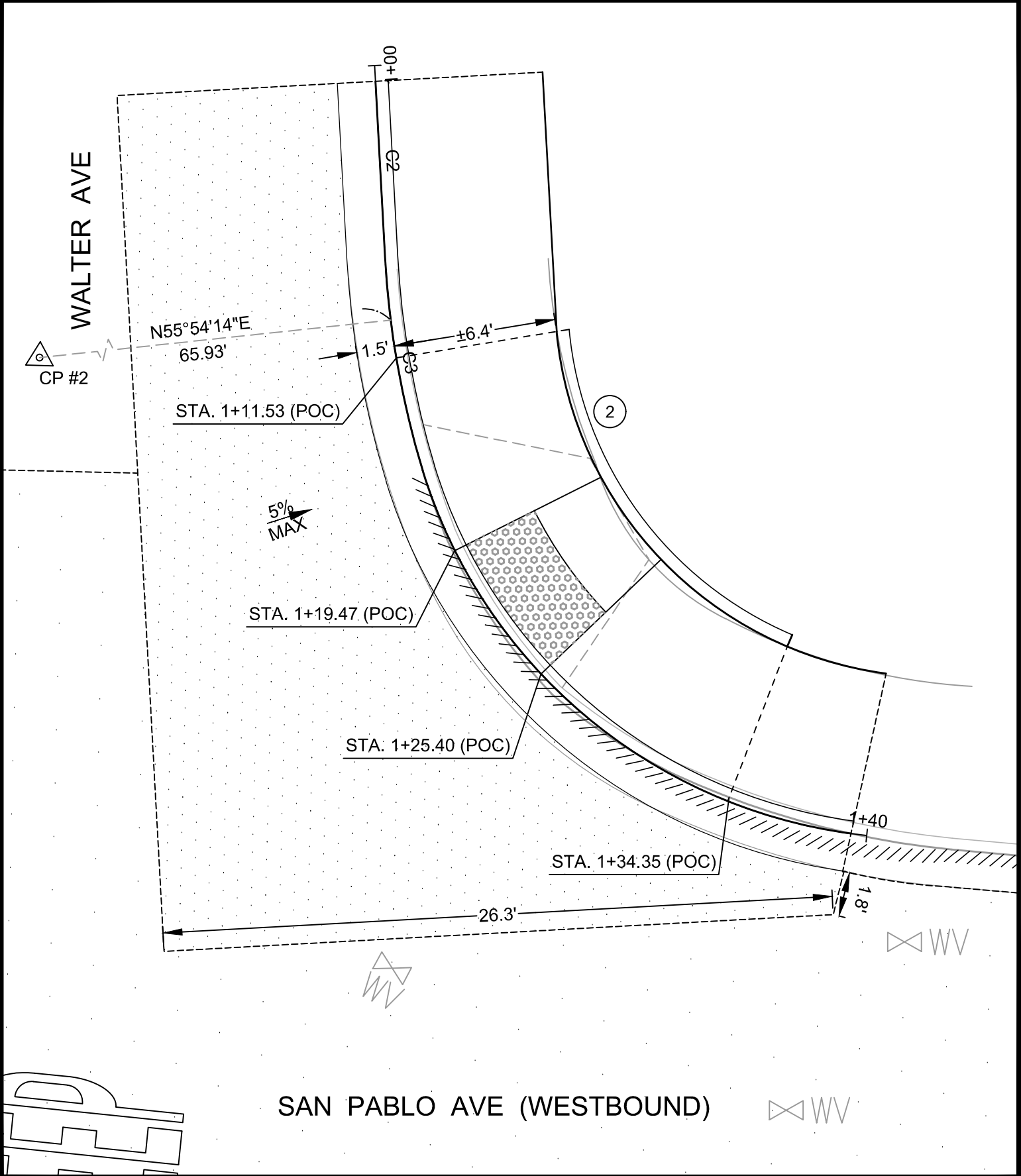

③ HORIZONTAL CONTROL - NE WALTER AVE CURB RAMP

SCALE: 1" = 5'

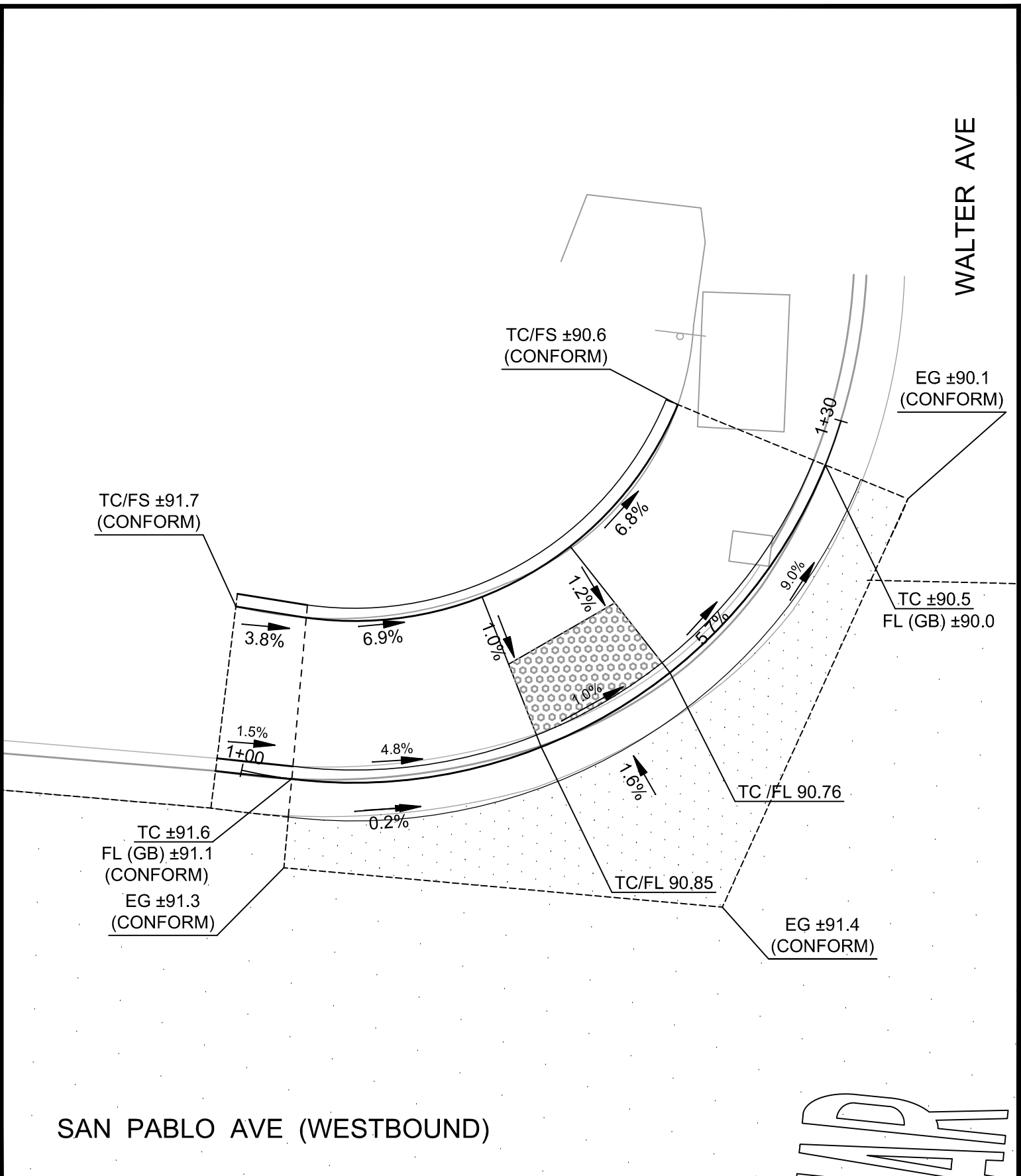

② GRADING DETAIL - NW WALTER AVE CURB RAMP

SCALE: 1" = 5'

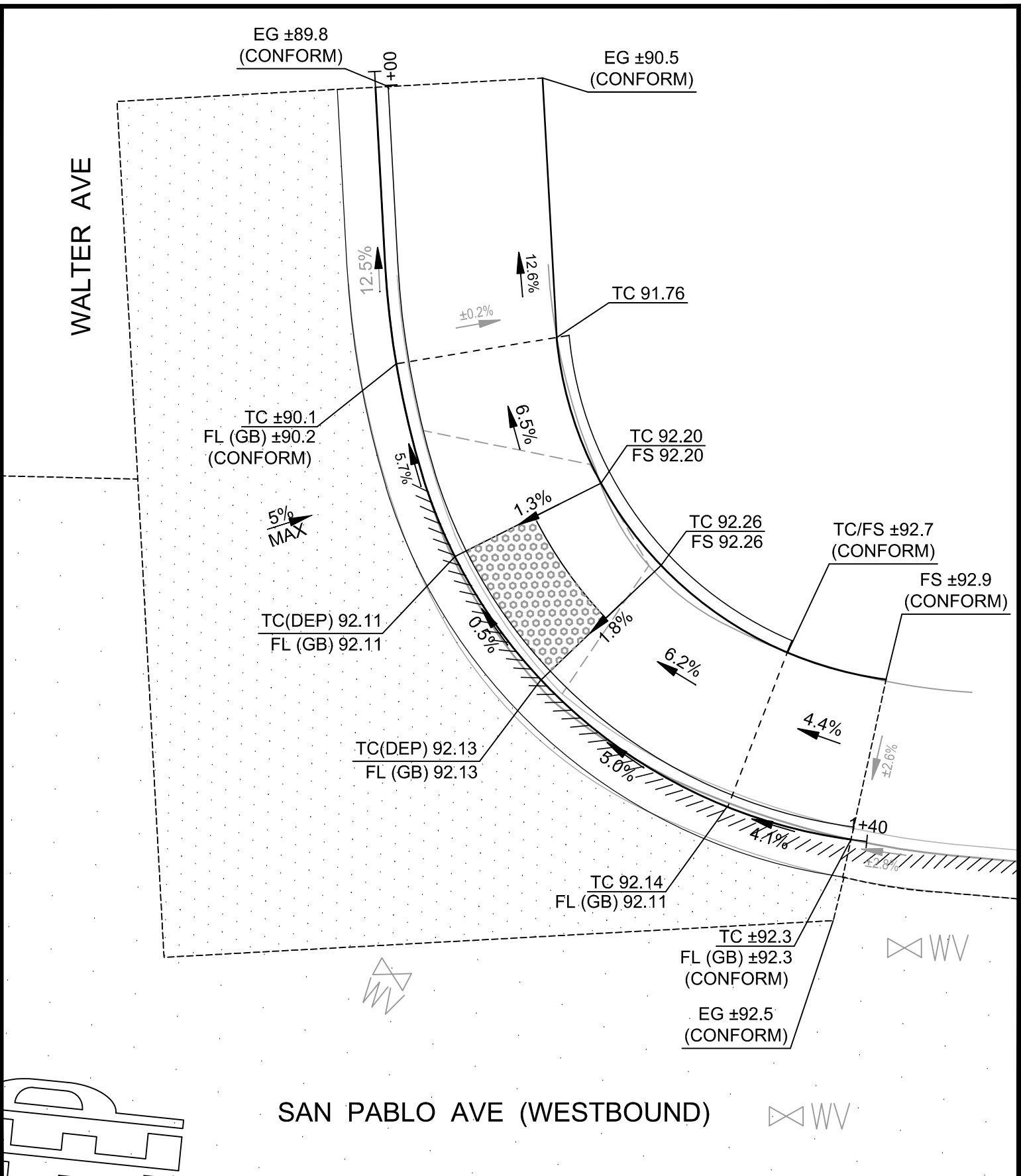

④ GRADING DETAIL - NE WALTER AVE CURB RAMP

SCALE: 1" = 5'

Graphic Scale (in feet)

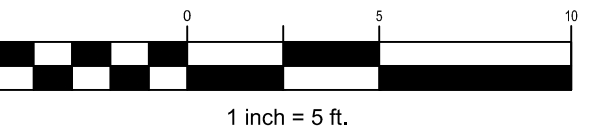

Rev	Date	Description	Designed	Drawn	Checked
-	07/14/21	BID SET	PW	RS	RS

CSW | ST2
CSW/Stuber-Stroeh Engineering Group, Inc.
 Civil & Structural Engineers | Surveying & Mapping | Environmental Planning
 Land Planning | Construction Management
 45 Leveroni Court, Novato, CA 94949
 Tel: 415.883.9850, Fax: 415.883.9835
<http://www.cswst2.com>

City: Pinole
 County: Contra Costa
 State: California



SAN PABLO AVE REHABILITATION
CURB RAMP PLAN
(WALTER AVE)
CITY OF PINOLE

Prepared Under the Direction of:

 RICHARD J. SOUZA
 No. 67892
 CIVIL
 STATE OF CALIFORNIA

Sheet **C3.04**
 Scale: 1" = 5'
 Date: 07/14/2021
 Project #: R01801
 Sheet #: 10 of 14

View: Berkeley\1BERLETT\Projects\21000222\Pinole_San_Pablo_Avenue_Rehabilitation\DWGS\Sheet\C3.04 - CURB RAMP PLAN (WALTER AVE).dwg, 07/13/2021 - 06:20 PM, Plank, 11

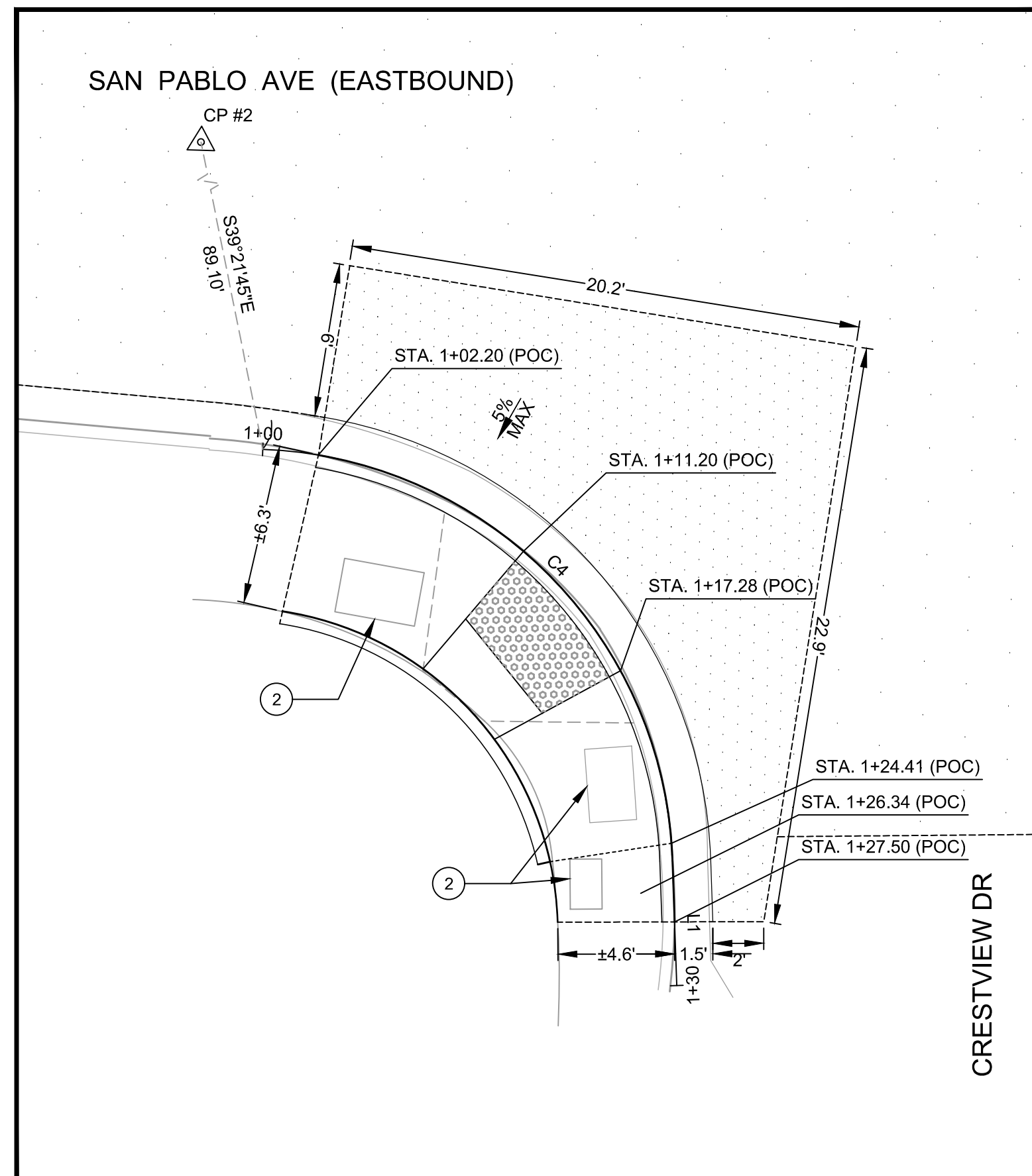

1 HORIZONTAL CONTROL - SW CRESTVIEW DR CURB RAMP
SCALE: 1" = 5'

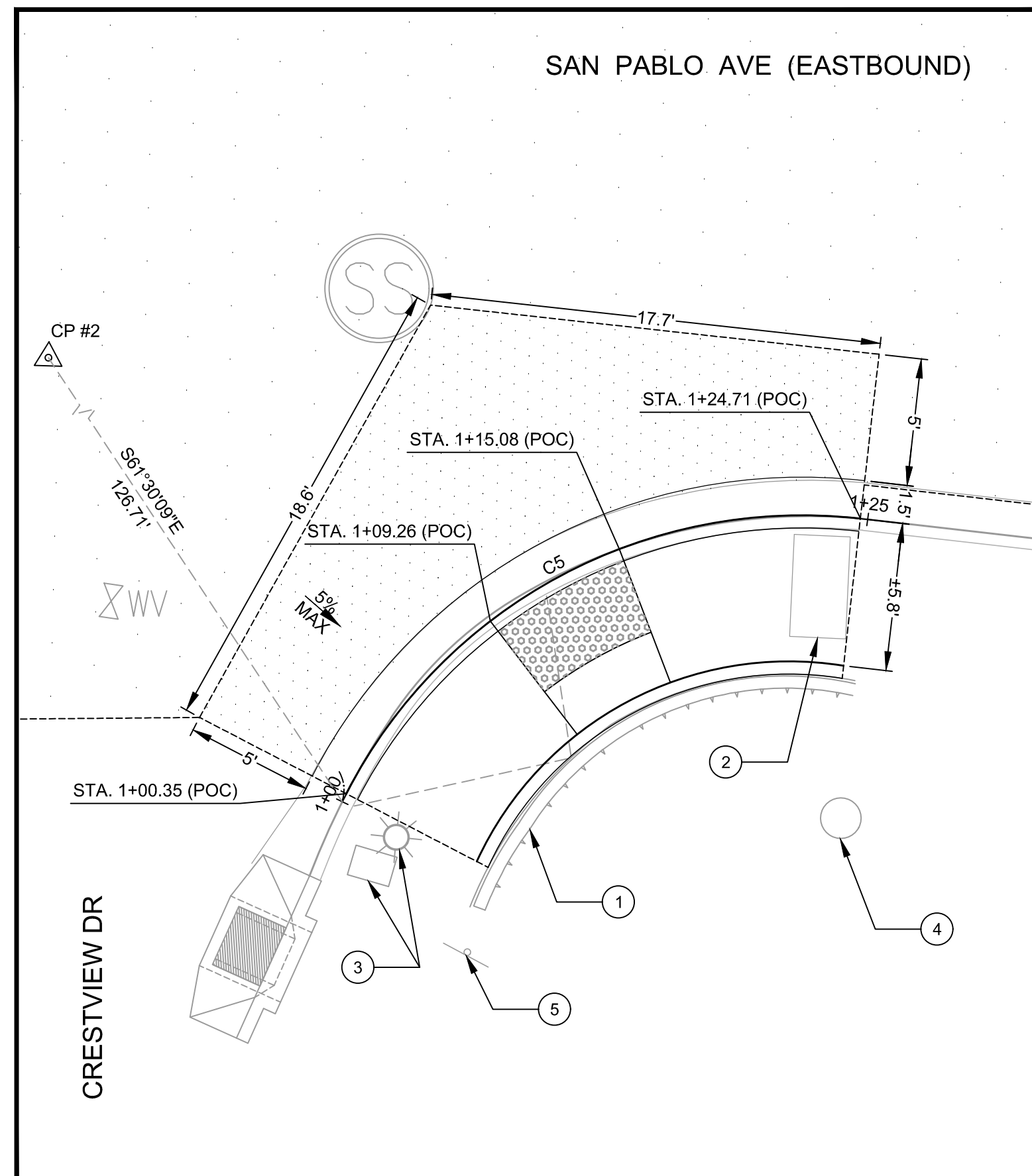

3 HORIZONTAL CONTROL - SE CRESTVIEW DR CURB RAMP
SCALE: 1" = 5'

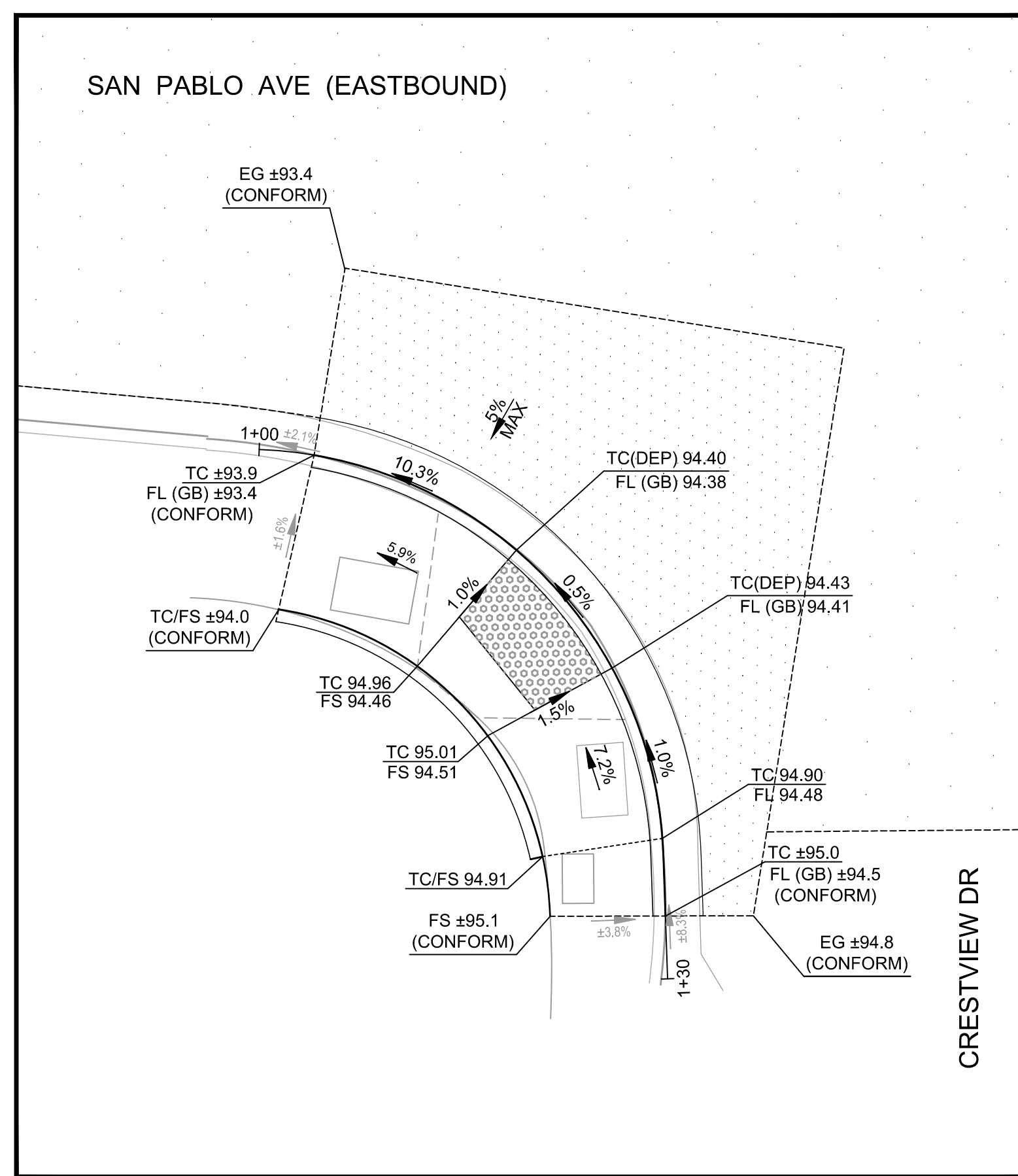

2 GRADING DETAIL - SW CRESTVIEW DR CURB RAMP
SCALE: 1" = 5'

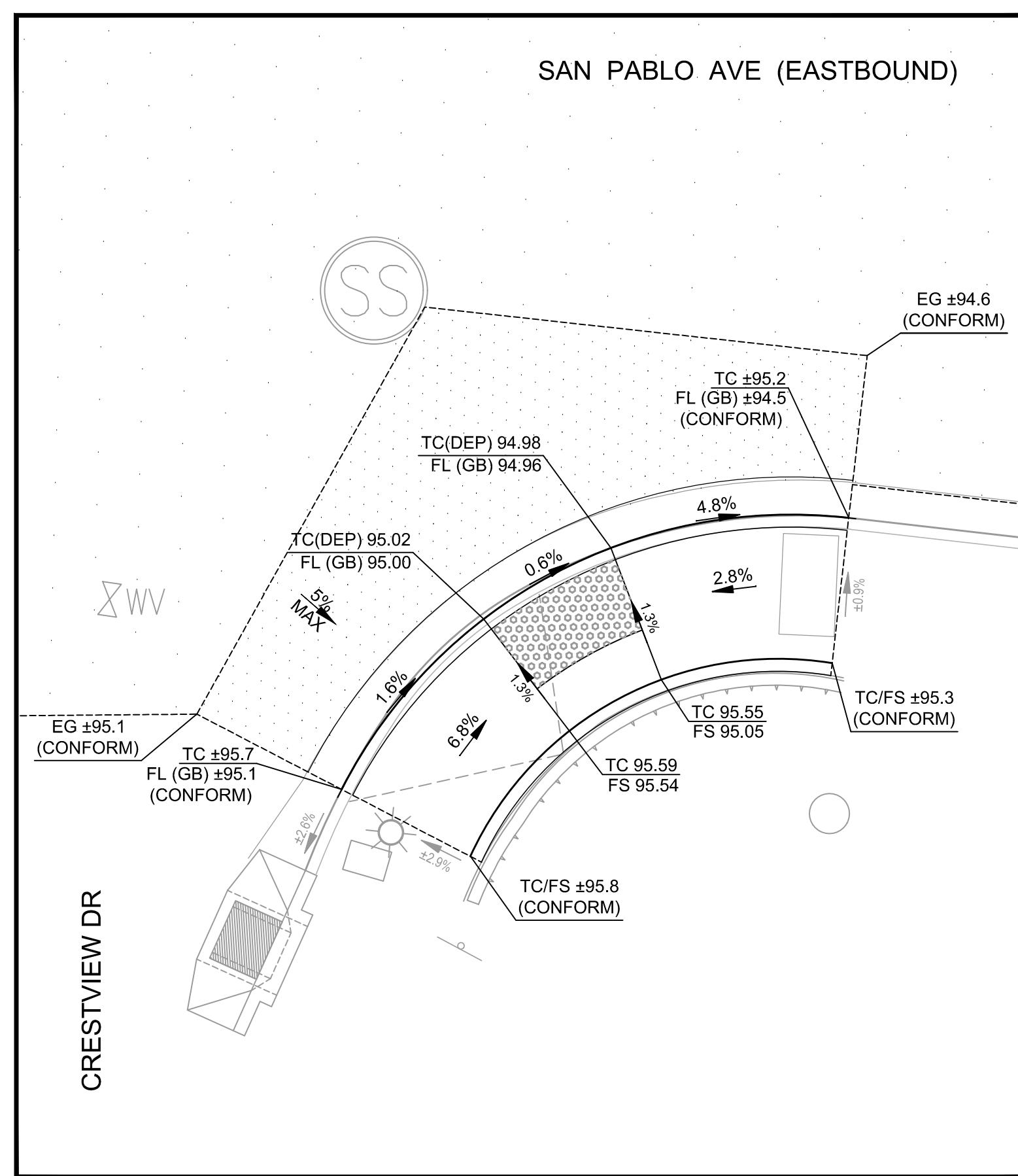

4 GRADING DETAIL - SE CRESTVIEW DR CURB RAMP
SCALE: 1" = 5'

SW CRESTVIEW DR ALIGNMENT						
TAG	STATION	NORTHING	EASTING	DELTA / BEARING	DISTANCE	RADIUS
C4	1+00.00	2193208.92	6039631.27	S72° 51' 31"E	25.10	16.75
L1	1+25.10	2193202.19	6039663.07	S29° 55' 46"E	4.90	

SE CRESTVIEW DR ALIGNMENT						
TAG	STATION	NORTHING	EASTING	DELTA / BEARING	DISTANCE	RADIUS
C5	1+00.00	2193217.35	6039686.12	N33° 44' 26"E	25.00	20.14

- KEYNOTES**
- 1 PROTECT IN PLACE EX. WALL
 - 2 ADJUST EX. UTILITY TO FINISHED GRADE
 - 3 PROTECT IN PLACE EX. UTILITY
 - 4 PROTECT IN PLACE EX. TREE
 - 5 PROTECT IN PLACE EX. SIGN

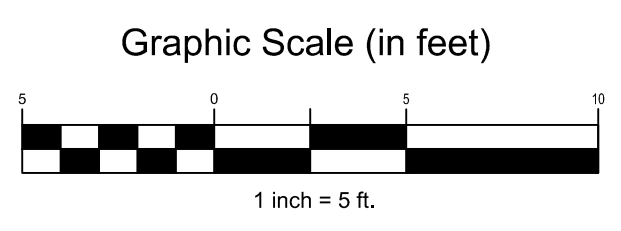

Rev	Date	Description	Designed	Drawn	Checked
-	07/14/21	BID SET	PW	RS	RS

CSW | ST2
CSW/Stuber-Stroeh Engineering Group, Inc.
 Civil & Structural Engineers | Surveying & Mapping | Environmental Planning
 Land Planning | Construction Management
 45 Leveroni Court, Novato, CA 94949
 tel: 415.883.9850
 fax: 415.883.9835
 http://www.cswst2.com

City Pinole
 County Contra Costa
 State California



SAN PABLO AVE REHABILITATION
CURB RAMP PLAN
(CRESTVIEW DR)
CITY OF PINOLE

Prepared Under the Direction of:

Sheet C3.05
 Scale: 1" = 5'
 Date: 07/14/2021
 Project #: R01801
 Sheet #: 11 of 14

View: Berkeley\BERLETT\Projects\2100022\Pinole_San_Pablo_Avenue_Rehabilitation\DWG\Sheet\C3.05 - CURB RAMP PLAN (CRESTVIEW DR).dwg 07/13/2021 - 06:21 PM Patrick 1:1

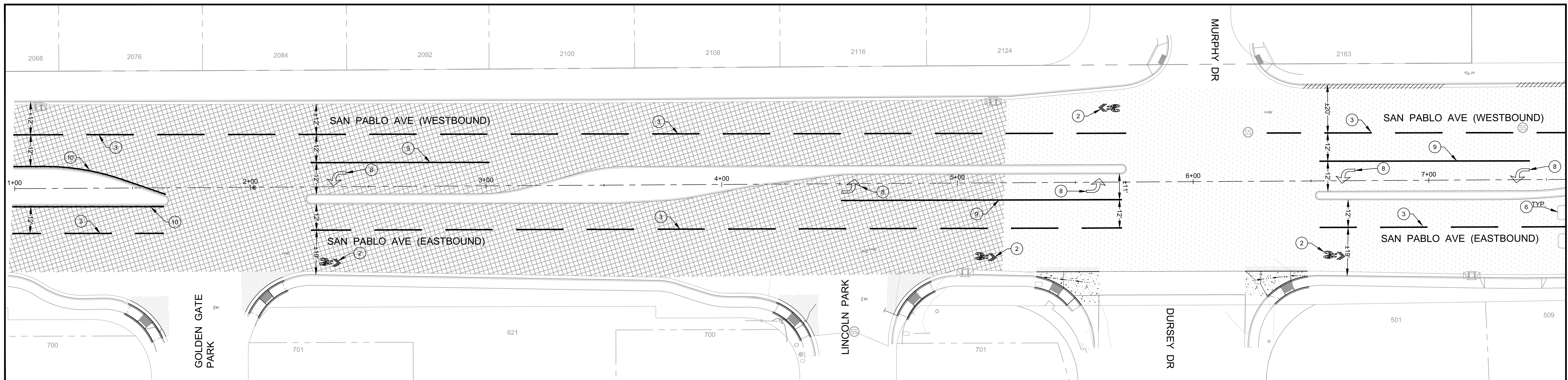

PLAN VIEW (CITY LIMITS - DURSEY/MURPHY)
SCALE: 1" = 20'

PAVEMENT MARKINGS:

- ↑ TYPE I ARROW (10 FT.) CALTRANS STD. PLAN A24E
- ↖ TYPE IV ARROW CALTRANS STD. PLAN A24A
- ↗ TYPE VII ARROW CALTRANS STD. PLAN A24A
- ▬ RED CURB

KEYNOTES

- ① STOP BAR/LIMIT LINE STRIPE (12-INCH - WHITE), DETAIL A24E
- ② BIKE SHARROW
- ③ DETAIL 9 LANE LINE
- ④ DETAIL 40 STRIPE
- ⑤ LADDER CROSSWALK STRIPE (24" WIDTH WITH 48" OC)
- ⑥ REPLACE LOOP DETECTOR
- ⑦ CROSSWALK STRIPE (12-INCH)
- ⑧ PAVEMENT ARROWS PER CALTRANS STD DETAILS
- ⑨ DETAIL 38 TURN LANE STRIPE
- ⑩ CONFORM DETAIL 25A (YELLOW) TO EXISTING AT CITY LIMITS

NOTES

1. PAVEMENT STRIPING AND MARKINGS PER CALTRANS STANDARD PLANS (2018).
2. DIMENSIONS MEASURED FROM CENTER OF STRIPING.
3. ALL TRAFFIC STRIPING AND PAVEMENT MARKINGS SHALL BE THERMOPLASTIC.

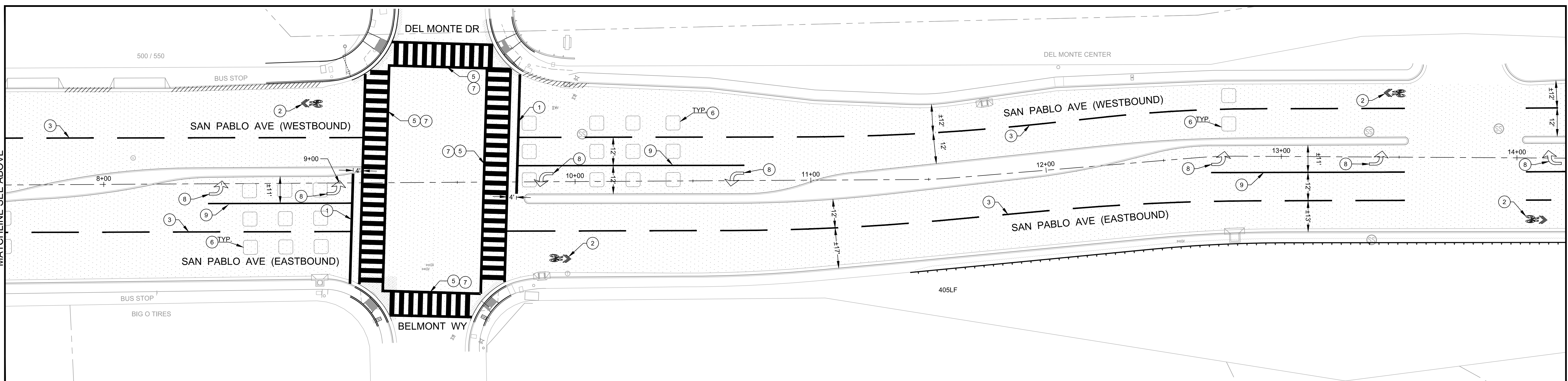
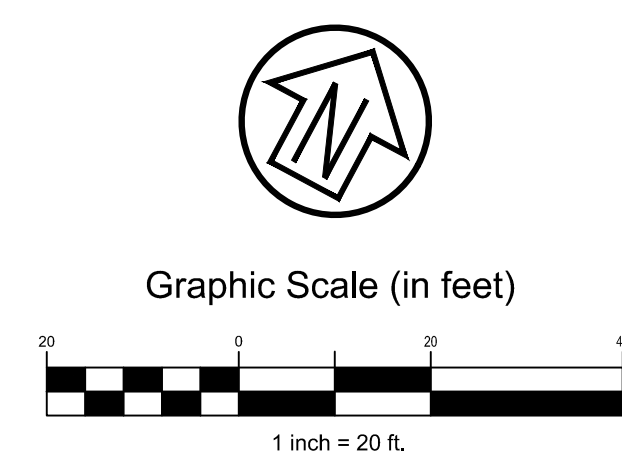

PLAN VIEW (BELMONT - DEL MONTE CENTER)
SCALE: 1" = 20'

Rev	Date	Description	Designed	Drawn	Checked
-	07/14/21	BID SET	PW	RS	RS

CSW ST2
CSW/Stuber-Stroeh Engineering Group, Inc.
 Civil & Structural Engineers | Surveying & Mapping | Environmental Planning
 Land Planning | Construction Management
 45 Leveroni Court Novato, CA 94949
 tel: 415.883.9850 fax: 415.883.9835
 http://www.cswst2.com

City Pinole
 County Contra Costa
 State California



SAN PABLO AVE REHABILITATION
PAVEMENT SIGNING & STRIPING PLAN
 CITY OF PINOLE

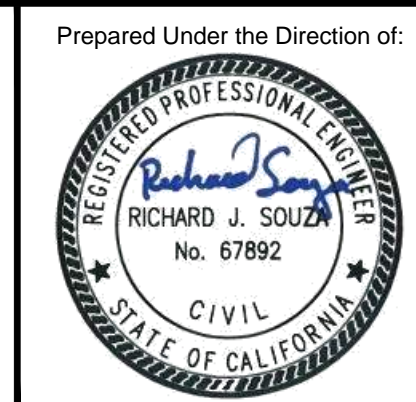

Prepared Under the Direction of:
C4.00
 Scale: 1" = 20'
 Date: 07/14/2021
 Project #: R01801
 Sheet #: 12 of 14

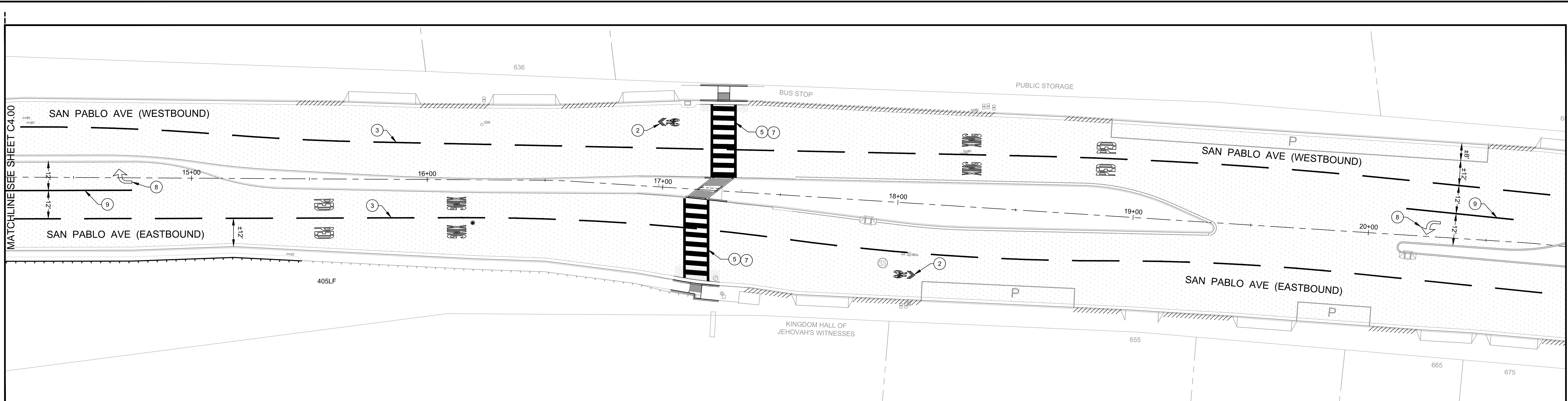

PLAN VIEW (DELMONTE CENTER TO WALTERS)
SCALE: 1" = 20'

PAVEMENT MARKINGS:

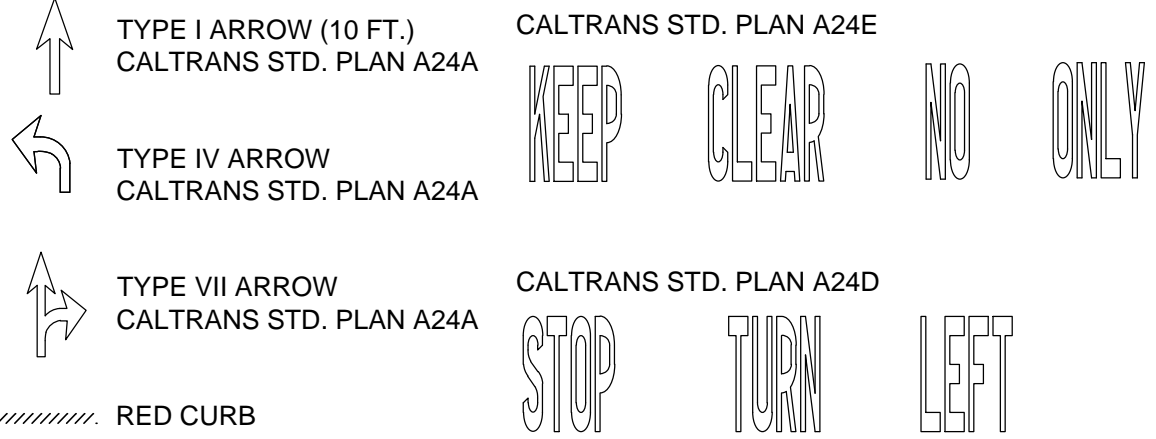

KEYNOTES

- 1 STOP BAR/LIMIT LINE STRIPE (12-INCH - WHITE), DETAIL A24E
- 2 BIKE SHARROW
- 3 DETAIL 9 LANE LINE
- 4 DETAIL 40 STRIPE
- 5 LADDER CROSSWALK STRIPE (24" WIDTH WITH 48" OC) SEE DETAIL 12, SHEET C5.00
- 6 REPLACE LOOP DETECTOR
- 7 CROSSWALK STRIPE (12-INCH)
- 8 PAVEMENT ARROWS PER CALTRANS STD DETAILS
- 9 DETAIL 38 TURN LANE STRIPE

NOTES

1. PAVEMENT STRIPING AND MARKINGS PER CALTRANS STANDARD PLANS (2018).
2. DIMENSIONS MEASURED FROM CENTER OF STRIPING.
3. ALL TRAFFIC STRIPING AND PAVEMENT MARKINGS SHALL BE THERMOPLASTIC.

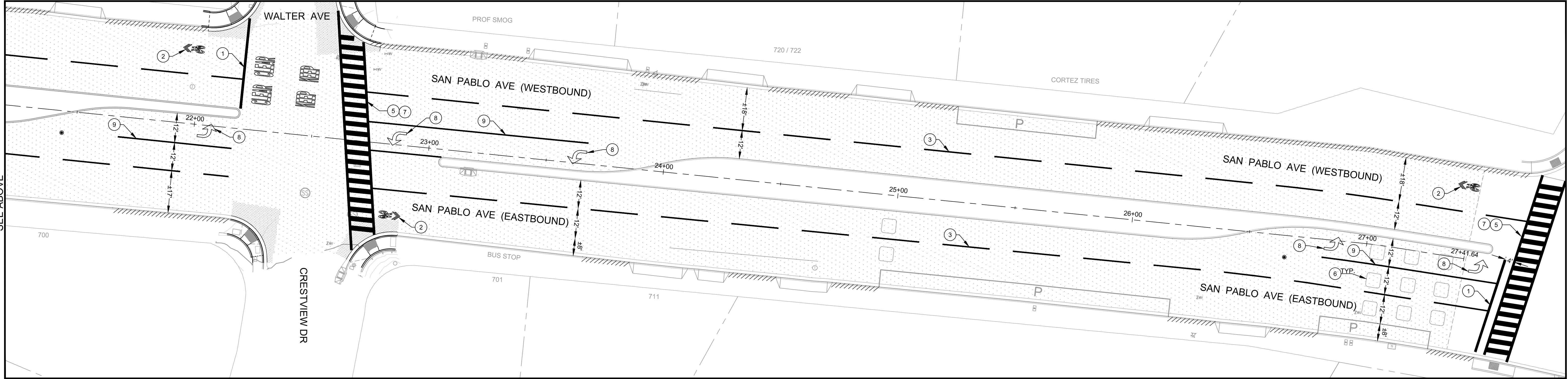
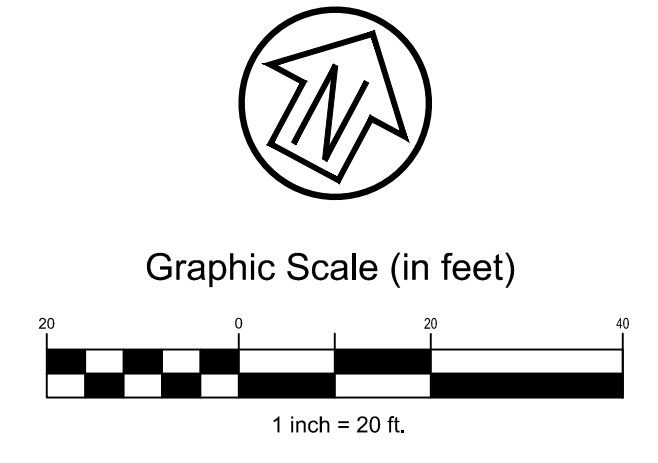

PLAN VIEW (WALTERS/CRESTVIEW - PINOLE SHORES)
SCALE: 1" = 20'

Rev	Date	Description	Designed	Drawn	Checked
-	07/14/21	BID SET	PW	RS	RS

CSW ST2
CSW/Stuber-Stroeh Engineering Group, Inc.
 Civil & Structural Engineers | Surveying & Mapping | Environmental Planning
 Land Planning | Construction Management
 45 Leveroni Court | Novato, CA 94949
 tel: 415.883.9850 | fax: 415.883.9835
 http://www.cswst2.com | 2021

City Pinole
 County Contra Costa
 State California



SAN PABLO AVE REHABILITATION
PAVEMENT SIGNING & STRIPING PLAN
 CITY OF PINOLE

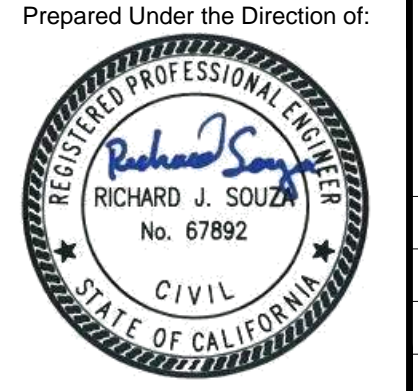

Prepared Under the Direction of: **Richard Souza**
 Sheet **C4.01**
 Scale: 1" = 20'
 Date: 07/14/2021
 Project #: R01801
 Sheet #: 13 of 14

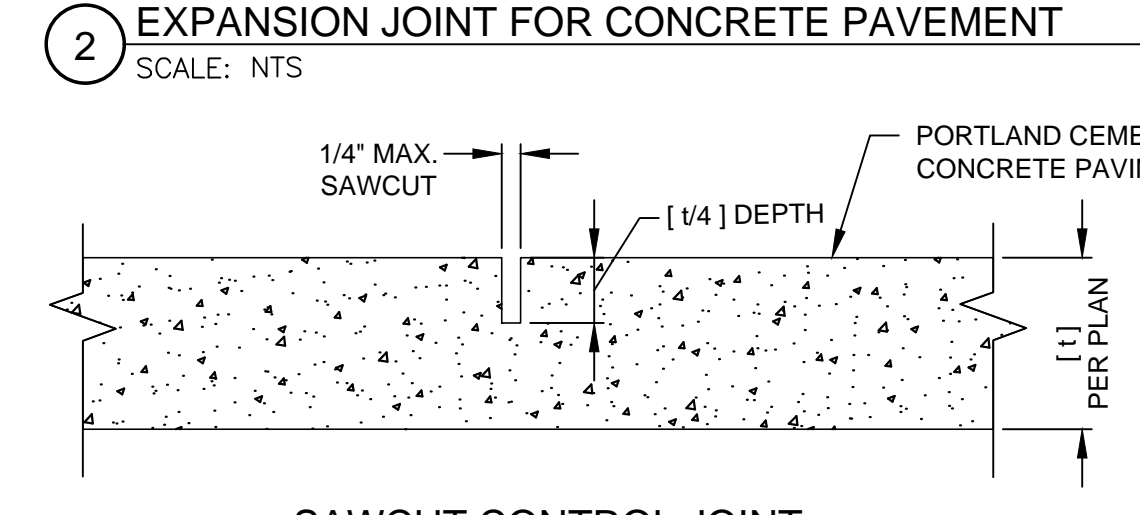
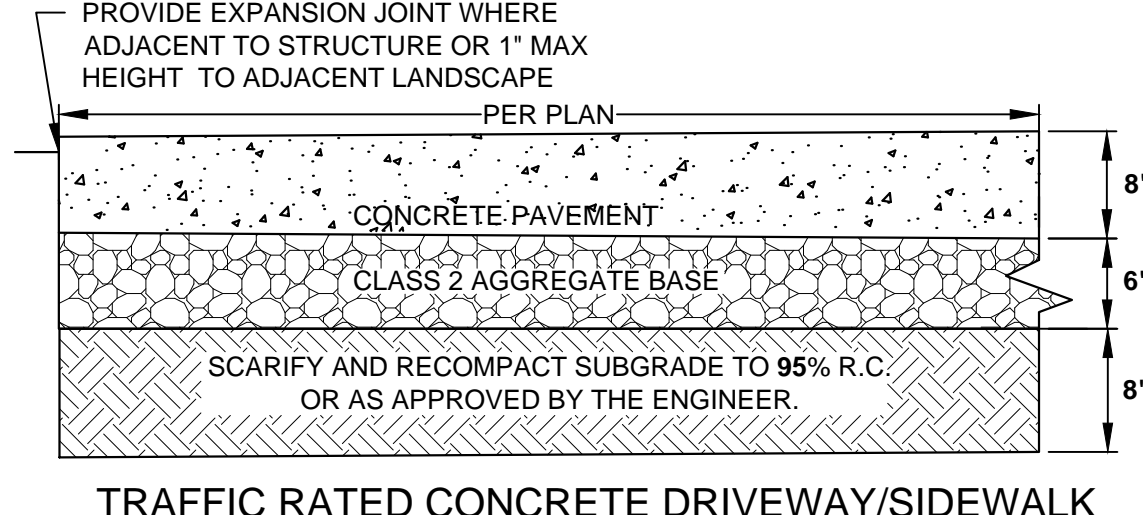
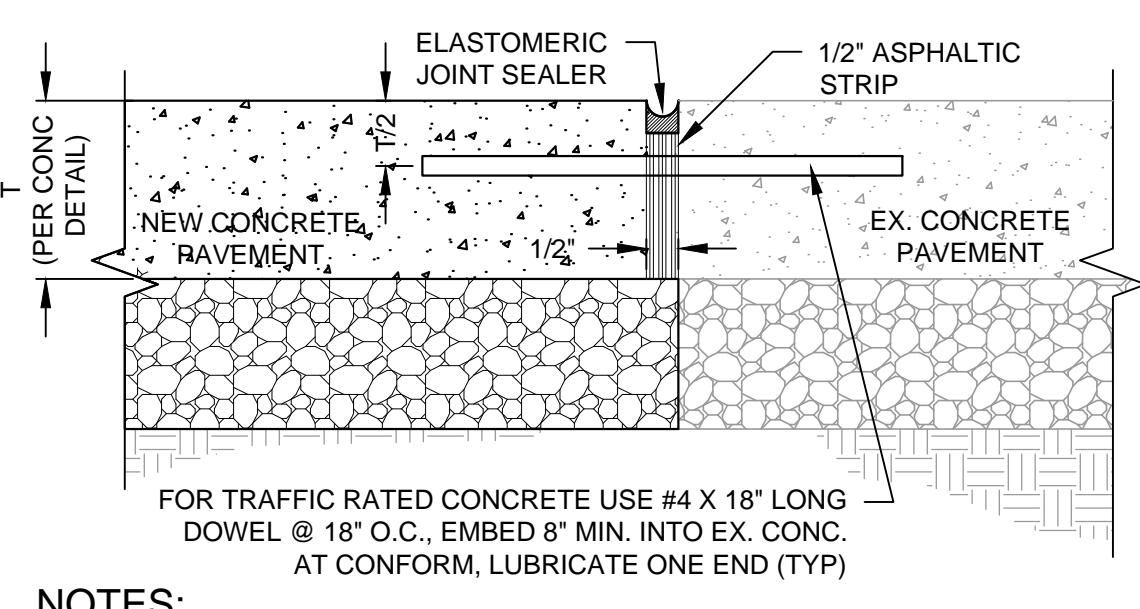
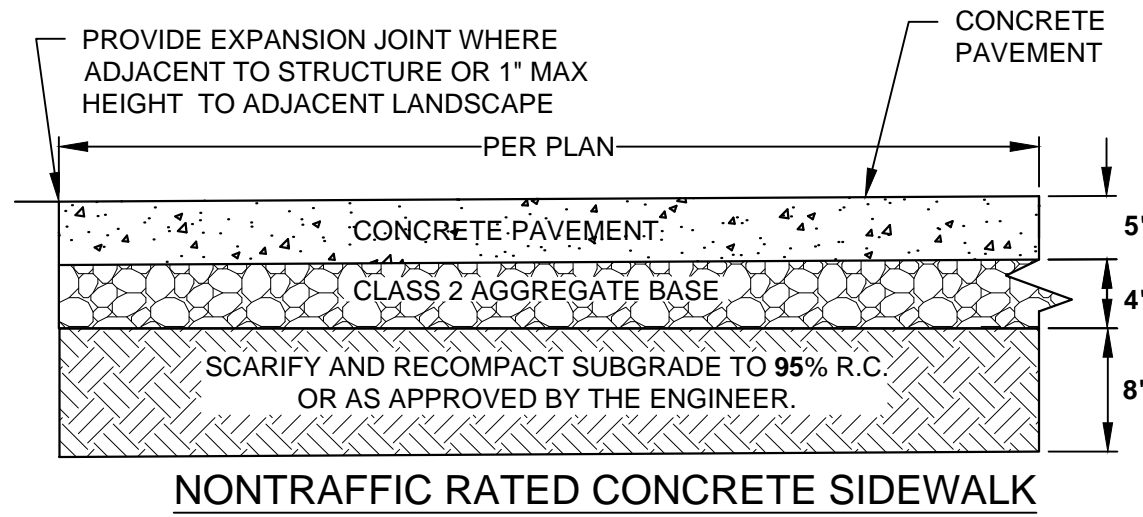

NOTES:

- ALL TREAD SURFACES SHALL BE SLIP RESISTANT
- AS APPLICABLE, REUSE OF EXISTING BASEROCK SHALL BE APPROVED BY THE ENGINEER

1 TYPICAL CONCRETE PAVEMENT DETAILS
SCALE: 1" = 1'

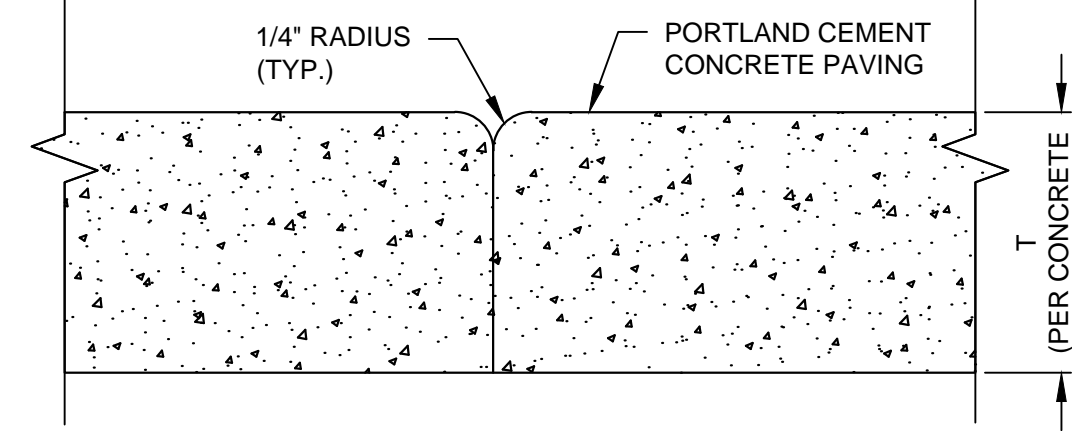

NOTES:

- CONSTRUCTION JOINTS SHALL BE CONSTRUCTED PER SPECIFICATIONS.
- CONSTRUCTION JOINTS SHALL EXTEND FULL DEPTH OF PAVING.

4 CONSTRUCTION JOINT FOR CONCRETE WALKWAYS
SCALE: NTS

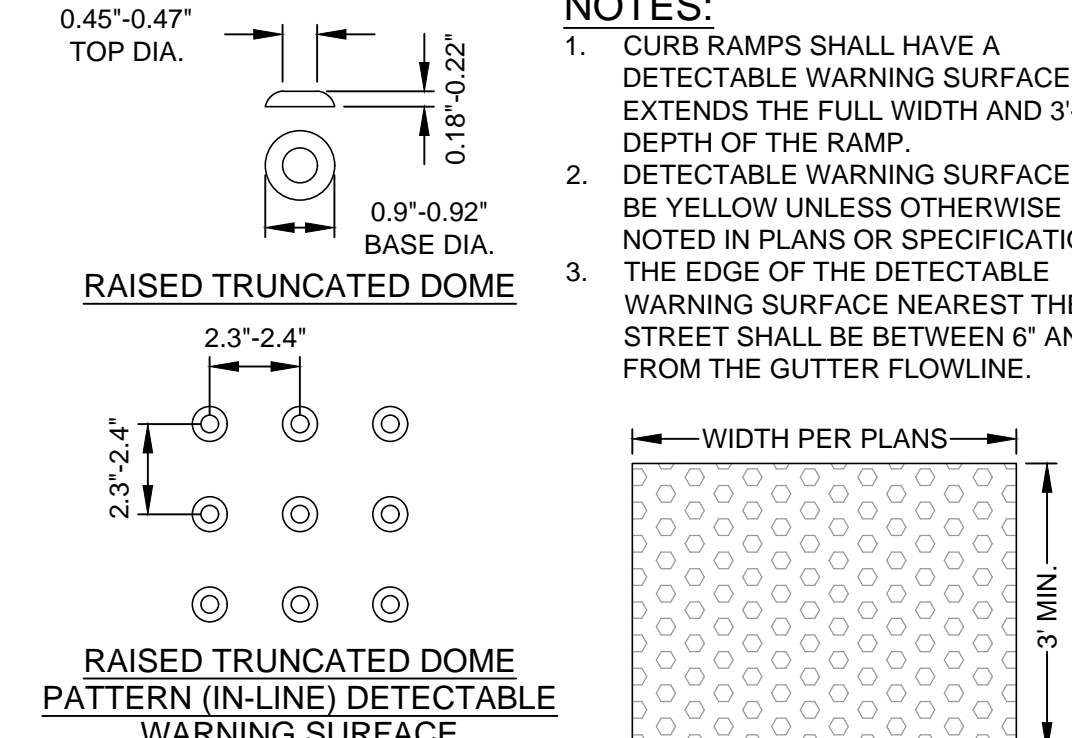

5 DETECTABLE WARNING SURFACE
SCALE: NTS

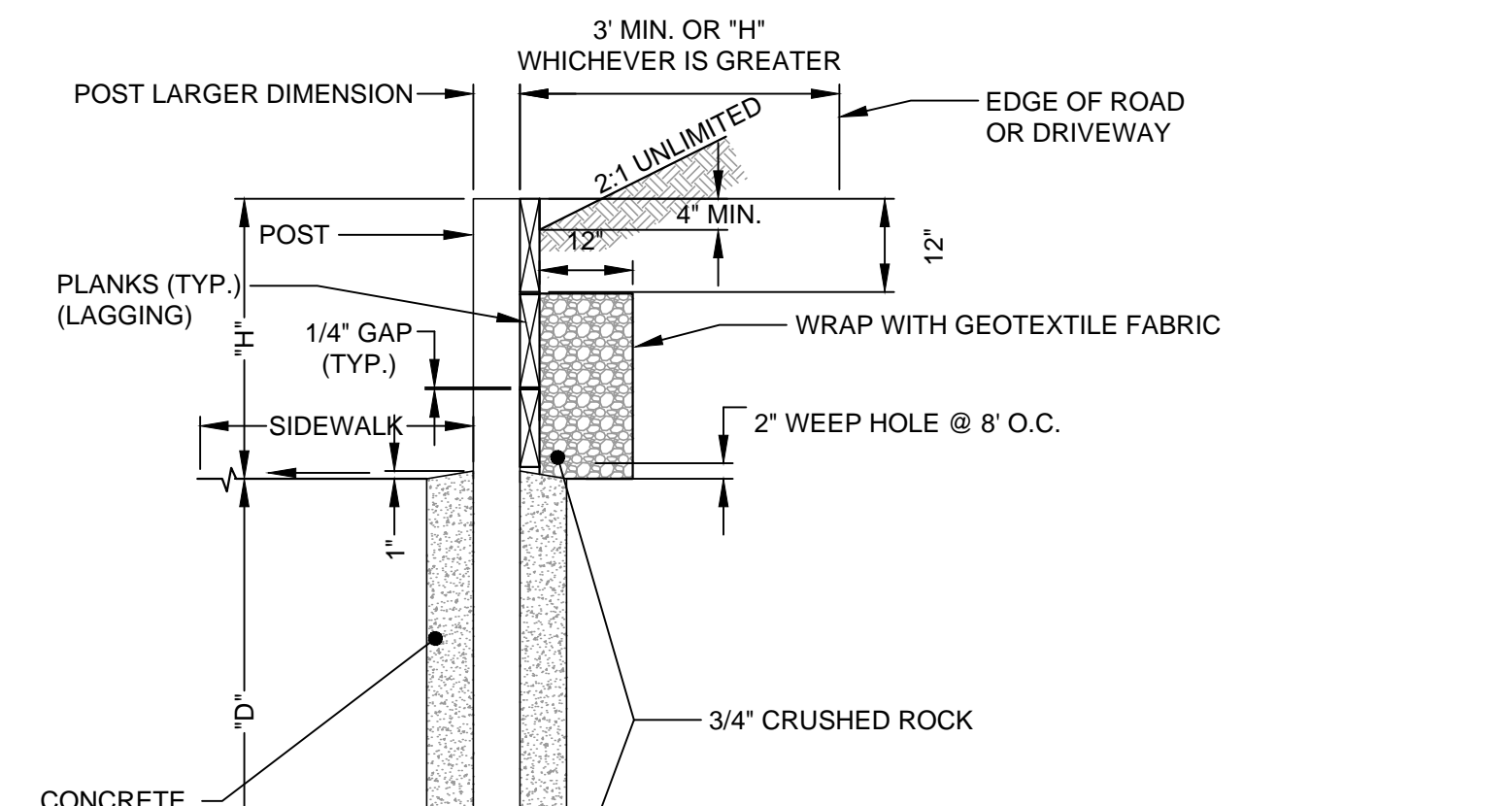

H	D	POST SPACING	POST SIZE
2'-0"	3'-6"	4'-0"	4"x4"
3'-0"	5'-0"	4'-0"	4"x6"
4'-0"	6'-0"	4'-0"	4"x6"

NOTES:

- LUMBER SHALL BE ROUGH DOUGLAS FIR No. 1 PRESSURE TREATED, AS APPROVED BY THE ENGINEER.
- PRESSURE TREATMENT SHALL MEET THE FOLLOWING: 0.40 pcf ACQ & CCA-C, 0.41 pcf CBA-A, 0.21 PCF CA-B.
- NAILS/METAL FASTENERS SHALL BE HIGH QUALITY CLASS G-185 HOT DIPPED GALVANIZED (ASTM A153 OR A653), 304 OR 316 STAINLESS STEEL, OR OTHER ACCEPTABLE CORROSION RESISTANT MATERIAL.
- ALL CUTS, HOLES AND INJURIES (SUCH AS ABRASIONS AND NAIL HOLES) SHALL BE FIELD TREATED WITH APPLICATIONS OF PRESERVATIVES IN ACCORDANCE WITH AWPA STANDARD M4.
- CONCRETE FOR POST SUPPORT SHALL BE CLASS C (4 SACK MIX) WITH 1" MAX. AGGREGATE.

6 WOODEN RETAINING WALL
SCALE: 1" = 2'

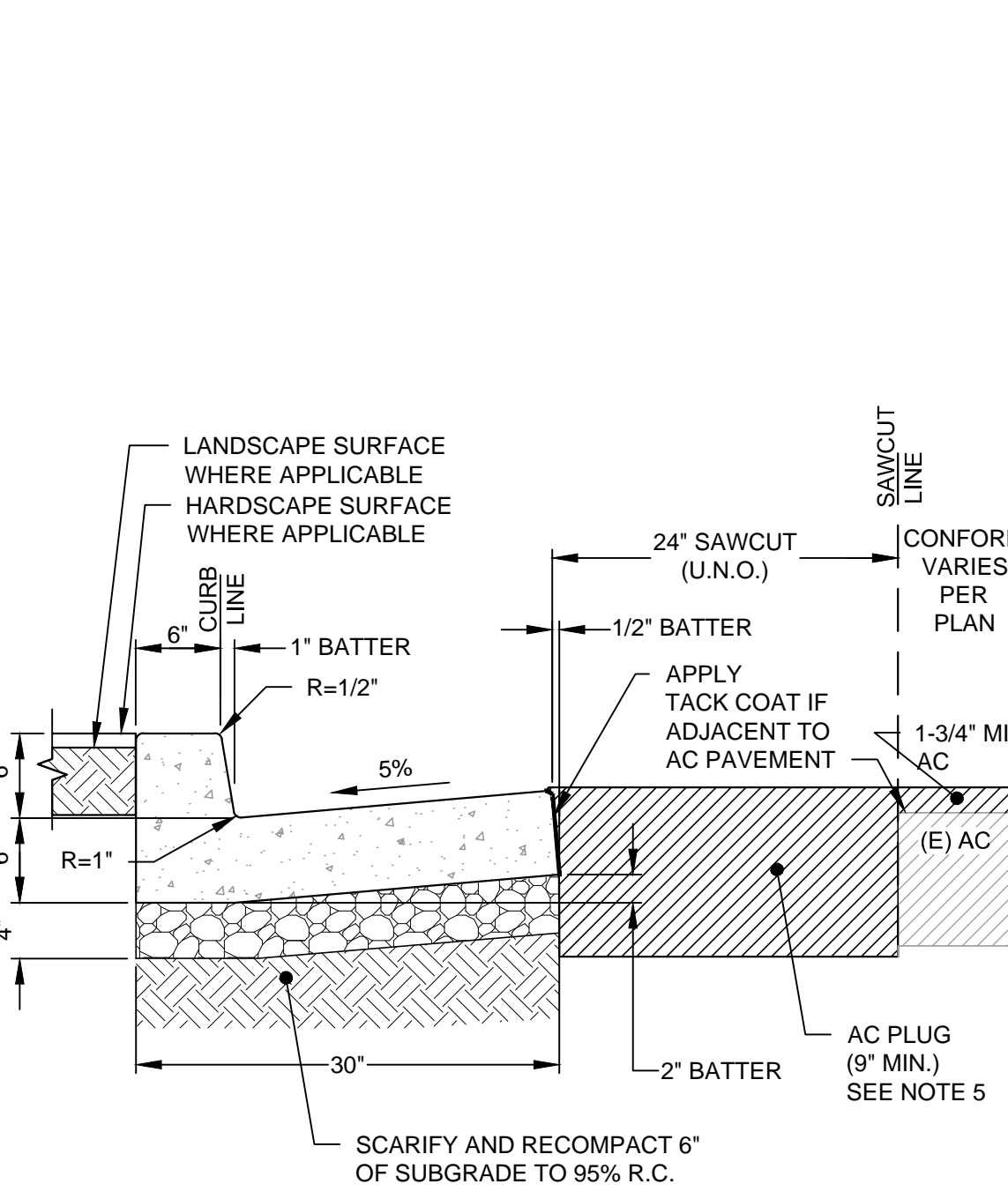

NOTES:

- POUR CURB AND GUTTER SEPARATE FROM CONCRETE WALK.
- CONTROL JOINTS CONSISTING OF 1" DEEP SCORES SHALL BE PLACED AT 10' INTERVALS O.C. - ALL SIDES EXCEPT BOTTOM.
- WHERE WALK IS ADJACENT TO CURB, THE JOINTS SHALL ALIGN WITH THE JOINTS IN THE CURB.
- GUTTER SLOPE SHALL BE 2% MAX AT CURB RAMP LANDINGS OR AS APPROVED IN THE FIELD BY THE ENGINEER.
- AC PLUGS FOR NEW CURB & GUTTERS SHALL BE 2" MIN WIDTH, AS INDICATED IN THE GRADING PLANS, THE EXISTING BASE MATERIAL MAY BE UTILIZED FOR CONFORMS BEYOND THE 2" WIDTH AC PLUGS.

7 TYPE "A" CONCRETE CURB & GUTTER
SCALE: 1" = 1'

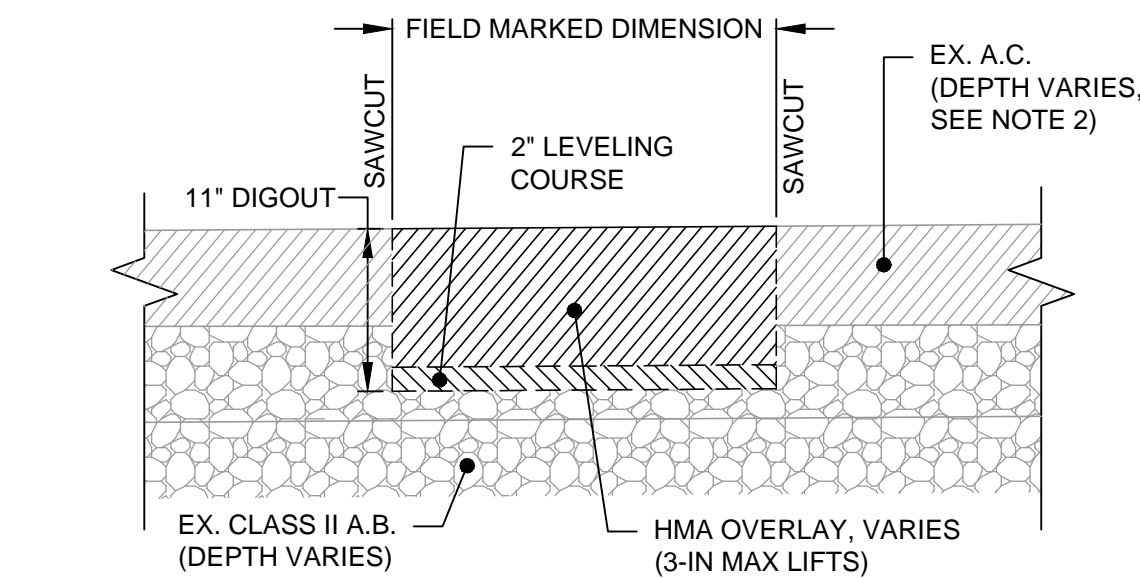

8 SAN PABLO AVE DIG OUT PAVEMENT REPAIR WEST CITY LIMIT TO LINCOLN PARK
SCALE: NTS

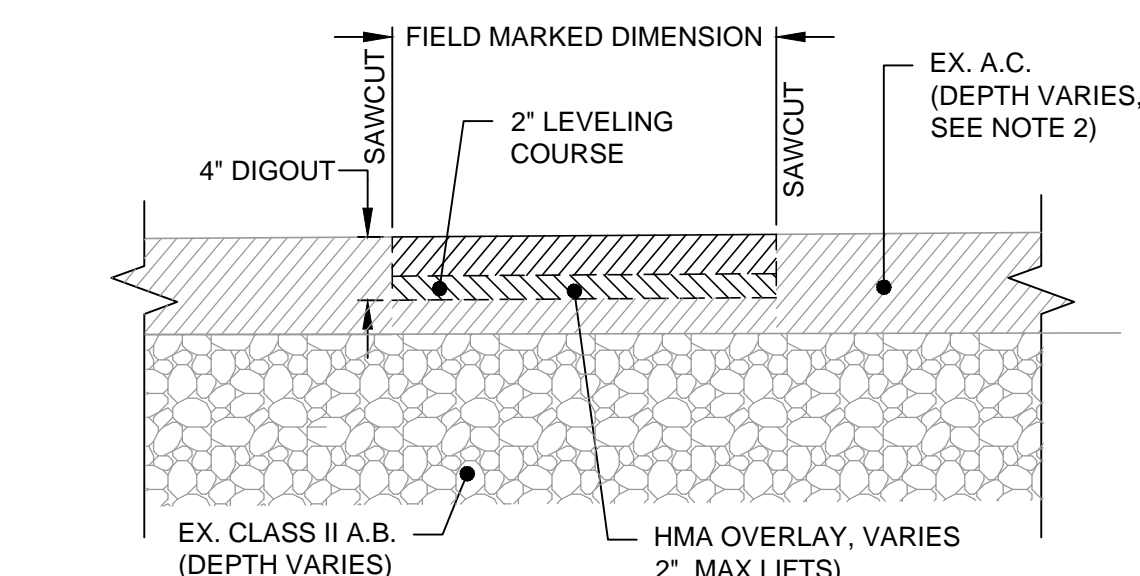

9 SAN PABLO AVE DIG OUT PAVEMENT REPAIR LINCOLN PARK TO PINOLE SHORES DRIVE
SCALE: NTS

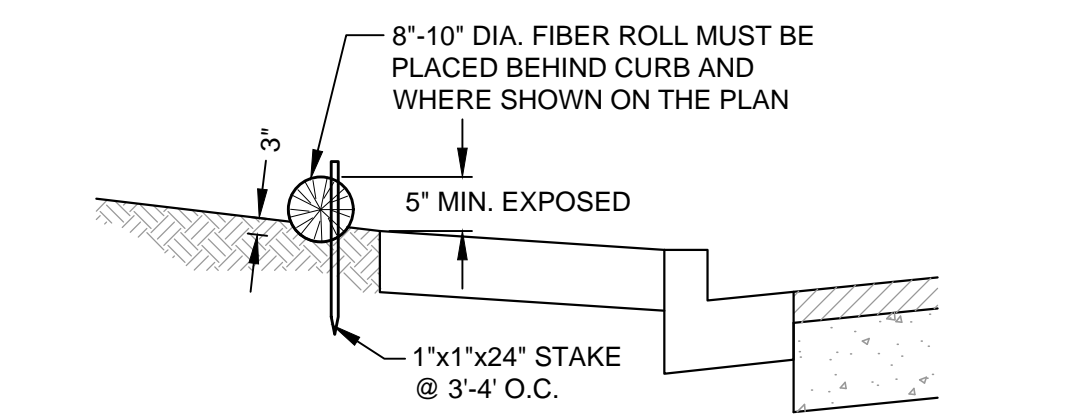

10 FIBER ROLL INSTALLATION DETAILS
SCALE: NTS

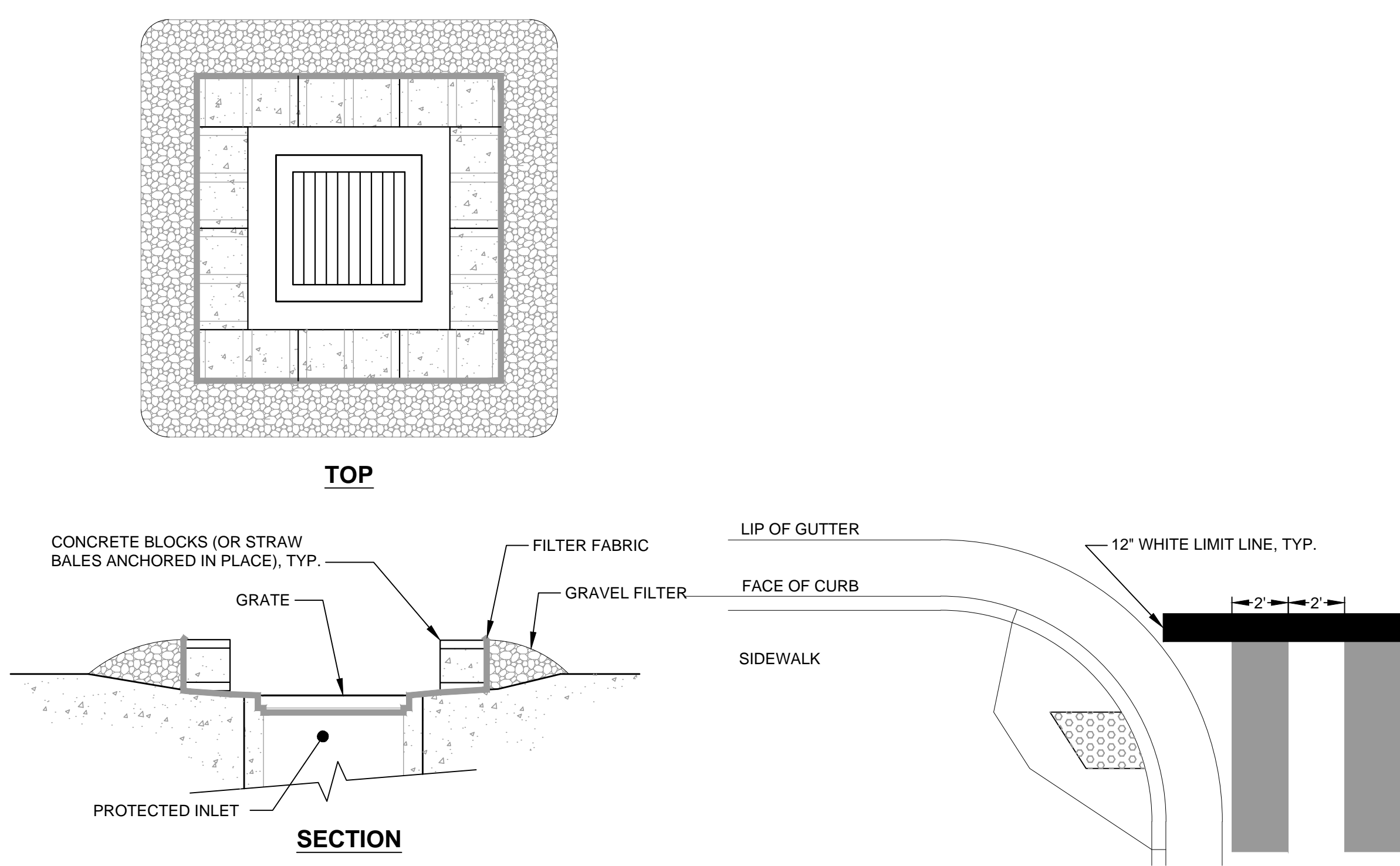

11 INLET PROTECTION DETAIL
SCALE: NTS

12 CROSSWALK STRIPING DETAIL
SCALE: NTS

Rev	Date	Description	Designed	Drawn	Checked
-	07/14/21	BID SET	PW	RS	RS

CSW ST 2

CSW/Stuber-Stroeh Engineering Group, Inc.
Civil & Structural Engineers | Surveying & Mapping | Environmental Planning
Land Planning | Construction Management

45 Leveroni Court
Novato, CA 94949
tel: 415.883.9850
fax: 415.883.9835
http://www.cswst2.com

City: Pinole
County: Contra Costa
State: California

SAN PABLO AVE REHABILITATION

DETAIL SHEET

CITY OF PINOLE

Prepared Under the Direction of:
REGISTERED PROFESSIONAL ENGINEER
RICHARD J. SOUZA
No. 67892
CIVIL
STATE OF CALIFORNIA

Sheet C5.00

Scale: As Shown
Date: 07/14/2021
Project #: R01801
Sheet #: 14 of 14